

STEREO INTEGRATED AMPLIFIER
KA-4040R
 SERVICE MANUAL

KENWOOD

KENW-03205

©1991-6 PRINTED IN JAPAN
 B51-4413-00(S)2007

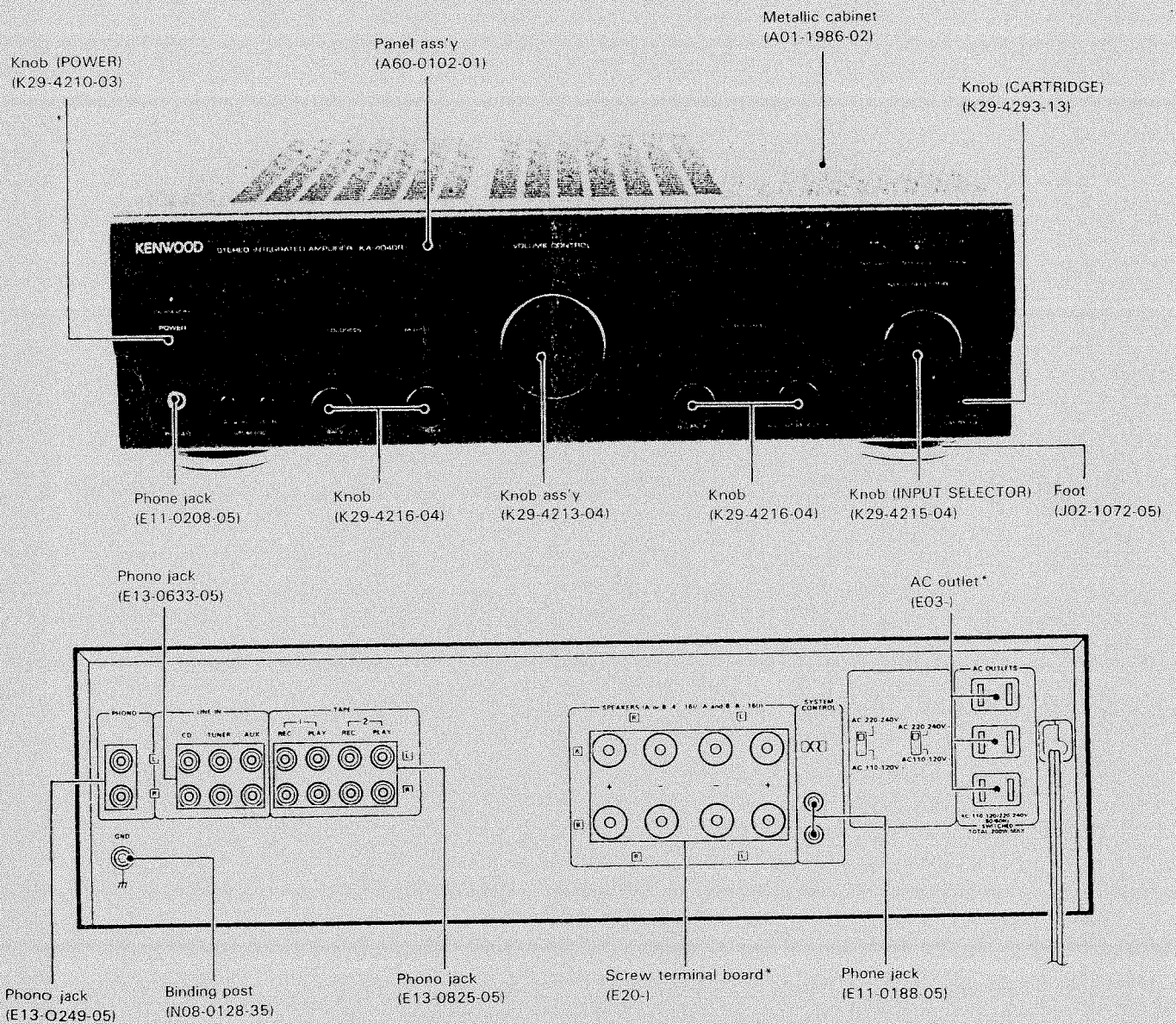

*Refer to parts list on page 25.

CONTENTS

REMOTE CONTROL OPERATION.....	3	SCHEMATIC DIAGRAM.....	17
CIRCUIT DESCRIPTION.....	4	EXPLODED VIEW.....	21
ADJUSTMENT/REGLAGE/ABGLEICH.....	10	PARTS LIST.....	23
WIRING DIAGRAM.....	11	SPECIFICATIONS.....	27
PC BOARD.....	13		

Accessories

Remote control unit..... 1
(X94-1000-00) (A09-0115-13: Battery cover)



Batteries
(R03/UM-4/"AAA"/)..... 2

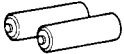

AC plug adaptor..... 1
(Except for some areas.)
For the unit with a European AC plug in areas other than Europe.
(E03-0115-05)



REMOTE CONTROL OPERATION

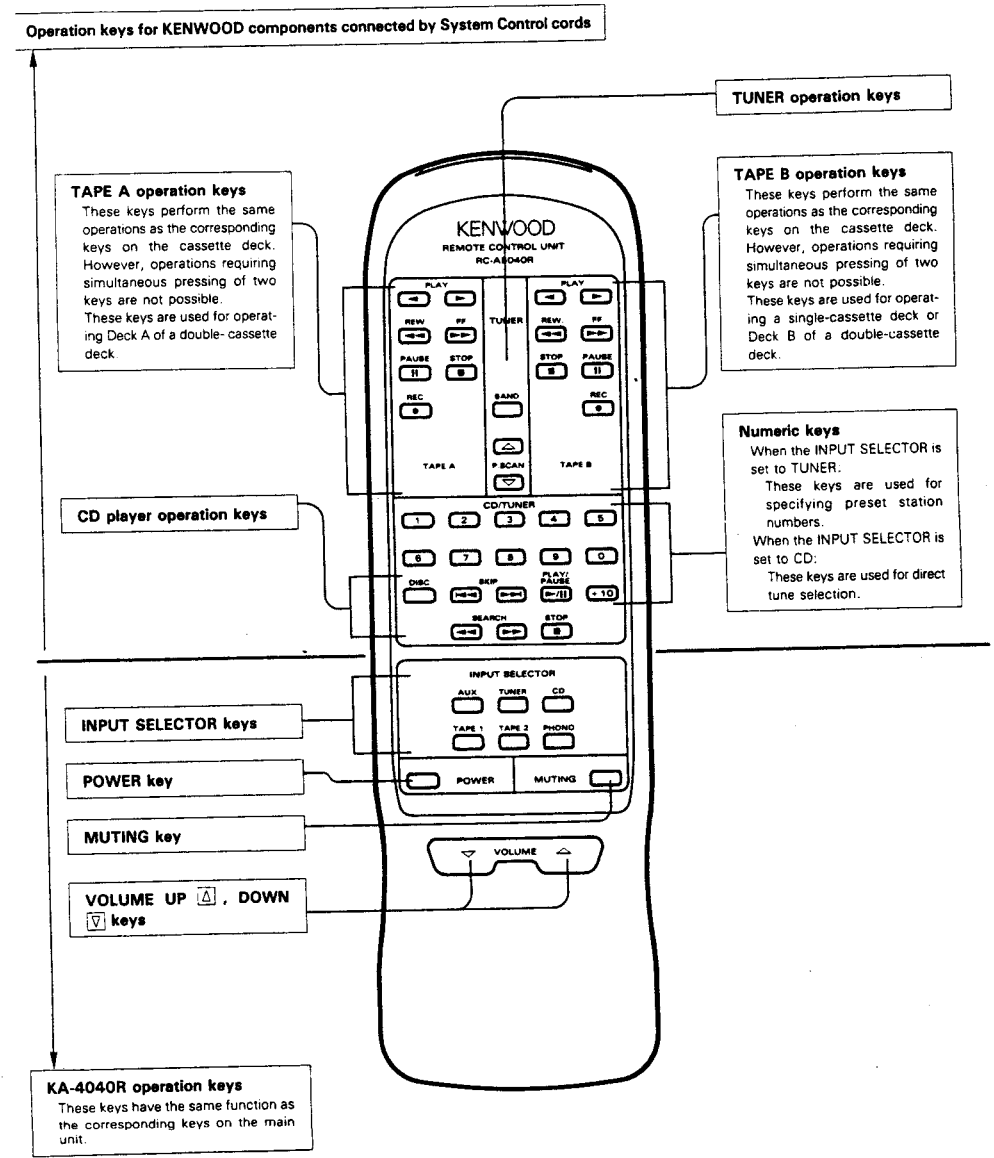

CIRCUIT DESCRIPTION

MICROPROCESSOR (μ PD75104G-778)

1. TEST MODE

1.1 Test Mode Using Mainframe Keys

(1) Setting

Plug in while pressing the SOURCE DIRECT key.

(2) Contents

- Switch the power on so that all LED indicators go on. Operate all TACT keys and the rotary encoder to cancel all the LED indicators that go on. In the all-light mode, all the INPUT SELECTOR LED indicators do not go on at the same time. The next SELECTOR LED indicator goes on approximately 100 ms after one SELECTOR LED indicator goes on in the same order as during input selector selection using the rotary encoder, because the output current exceeds the absolute maximum rating when all the INPUT SELECTOR LED indicators go on, since each LED indicator is directly driven by a microcomputer.
- When the LOUDNESS key is pressed while the test mode is set with a mainframe key, The electromotive VOLUME decreases. When the MUTING key is pressed, the VOLUME increases. The VOLUME stops when the SOURCE DIRECT key is pressed.

(3) Cancellation

- Plug off. If there a backup function is to be used, plug off and destroy the backup check data when a test mode flag is set during backup operation.

2. INITIALIZING

Insert the AC plug into a wall outlet while pressing the POWER key.

3. Diagram of microcomputers peripheral equipment

CIRCUIT DESCRIPTION

KA-4040R

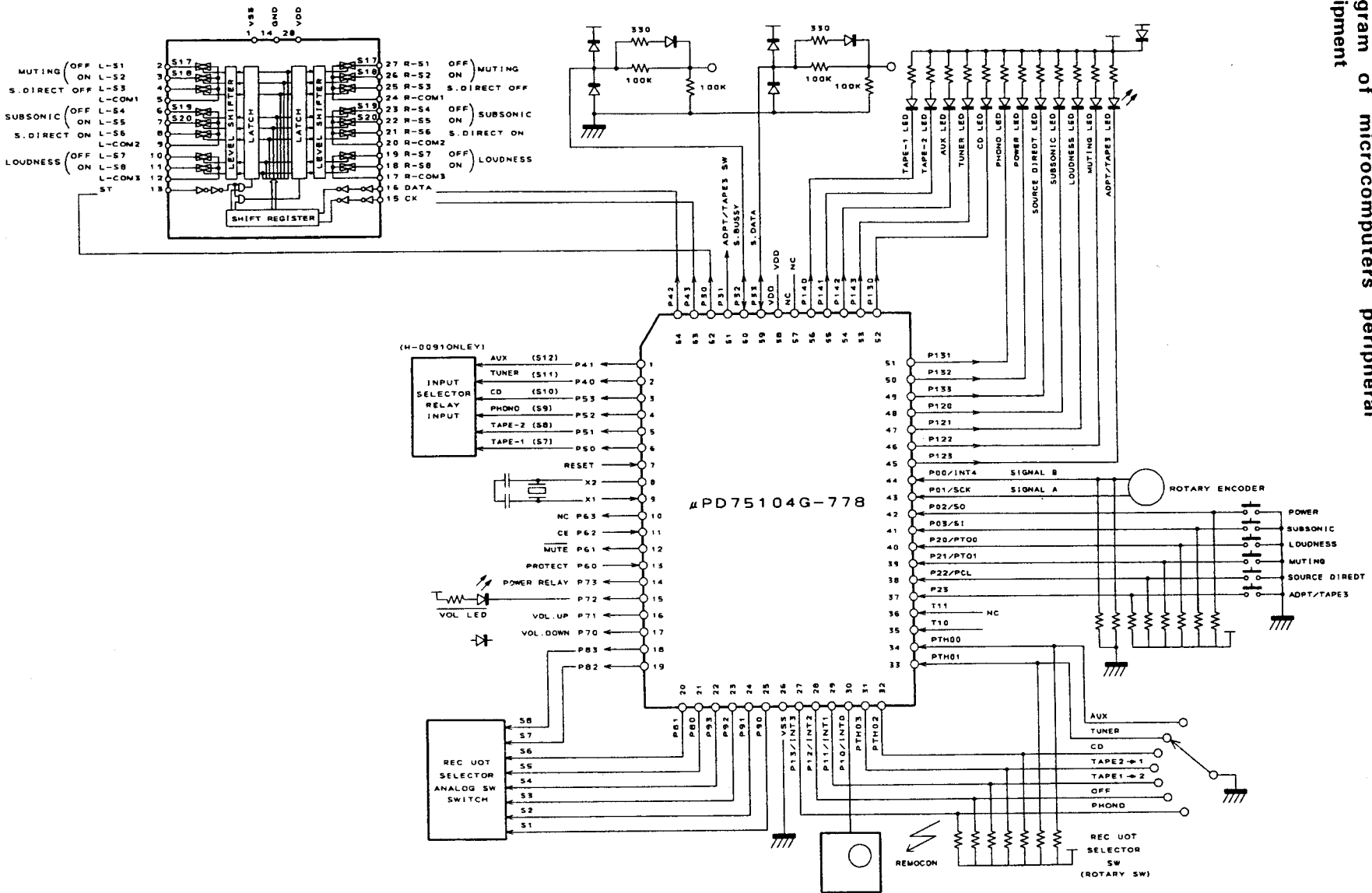

CIRCUIT DESCRIPTION

4. PIN CONNECTIONS

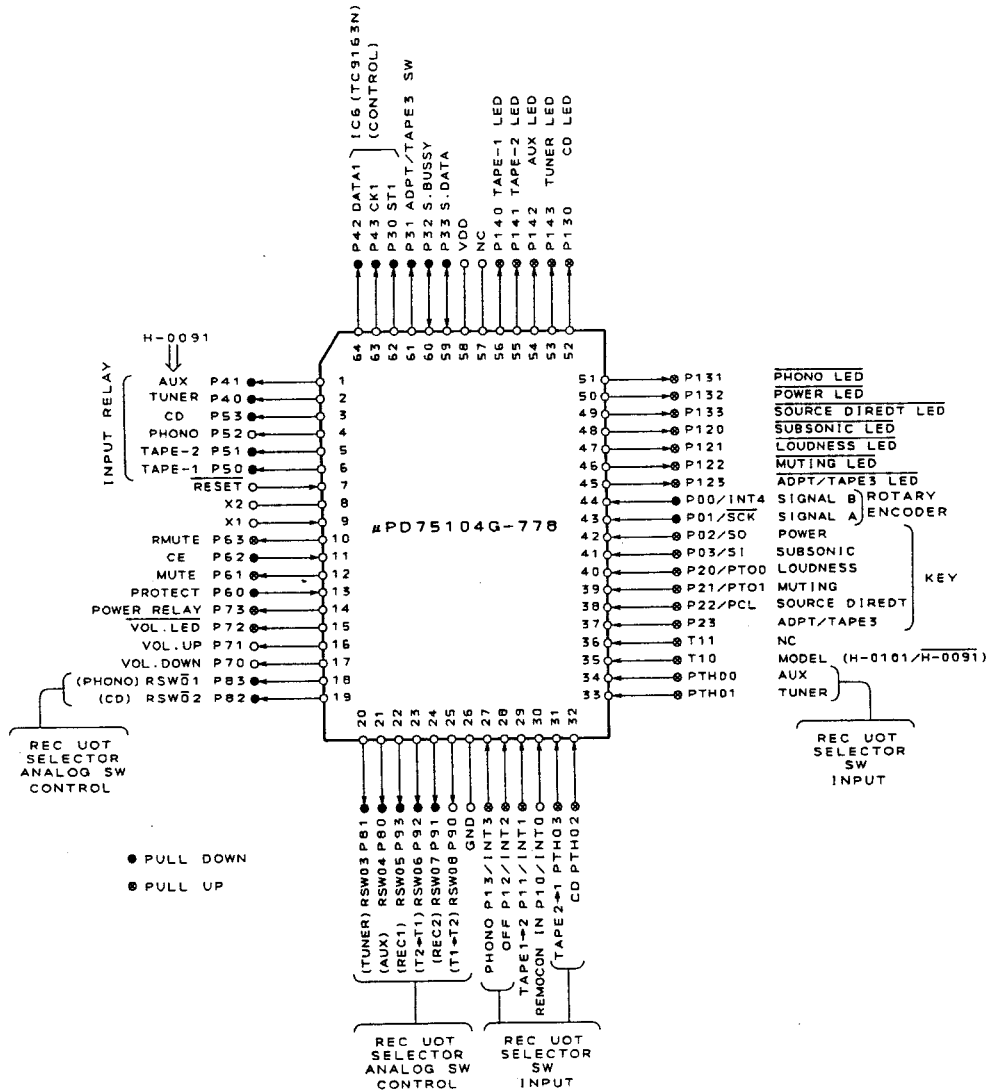

CIRCUIT DESCRIPTION

Pin No.	Pin name	I/O	Name	Description
1	P41	O	SRAUX	AUX SELECTOR RELAY control pin (high when active). Outputs a low signal in the backup mode.
2	P40	O	SRTUNER	TUNER SELECTOR RELAY control pin (high when active). Outputs a low signal in the backup mode.
3	P53	O	SRCD	CD SELECTOR RELAY control pin (high when active). Outputs a low signal in the backup mode.
4	P52	O	SRPHONO	PHONO SELECTOR RELAY control pin (high when active). Outputs a low signal in the backup mode.
5	P51	O	SRTAPE2	TAPE2 SELECTOR RELAY control pin (high when active). Outputs a low signal in the backup mode.
6	P50	O	SRTAPE1	TAPE1 SELECTOR RELAY control pin (high when active). Outputs a low signal in the backup mode.
7	/RESET	I		Microcomputer reset input pin.
8	X2	O		Ceramic connection pin for microcomputer system clock oscillation (4.19 MHz).
9	X1	I		
10	P63	O	RMUTE	Unused. Enters the input mode during backup.
11	P62	I	/CE	Backup state detection pin (low when active). Enters the input mode during backup.
12	P61	O	MUTE	Mute signal output pin (high when active). Enters the input mode during backup.
13	P60	I	PROTECT	Protect state detection pin (high when active). The POWER LED indicator blinks when a high signal is input to this pin during the power-on sequence. Enters the input mode during backup.
14	P73	O	POWER RELAY	POWER RELAY control pin. POWER ON: High POWER OFF: Low Enters the input mode during backup.
15	P72	O	VOL. LED	Volume index LED control pin. Goes ON: Low Goes OFF: High Enters the input mode during backup.
16	P71	O	VOL. UP	Electromotive volume control Up signal output pin. Volume control Up: High Except volume control Up: Low Enters the input mode during backup.
17	P70	O	VOL. DOWN	Electromotive volume control Down signal output pin. Volume control Down: High Except volume control Down: Low
18-25	P83-P90	O	RSW08-RSW01	Control signal output pin of REC OUT SELECTOR analog switch (high when active). Outputs a signal according to the REC Out selector state as shown on the attached sheet. Outputs a low signal in the backup mode.
26	Vss		GND	Microcomputer GND pin.
27	P13/INT3	I	RSWI (PHONO)	REC out selector state setting input pin (PHONO). (Low when active.)
28	P12/INT2	I	RSWI (OFF)	REC out selector state setting input pin (OFF). (Low when active.)
29	P11/INT1	I	RSWI (TAPE1-2)	REC out selector state setting input pin (TAPE1→TAPE2). (Low when active.)

KA-4040R

CIRCUIT DESCRIPTION

Pin No.	Pin name	I/O	Name	Description
30	PIO/INITO	I	REMOCON IN	Remote control signal input pin.
31	PTH03	I	RSWI (TAPE2→1)	REC out selector state setting input pin (TAPE2 → TAPE1). (Low when active.)
32	PTH02	I	RSWI (CD)	REC out selector state setting input pin (CD). (Low when active.)
33	PTH01	I	RSWI (TUNER)	REC out selector state setting input pin (TUNER). (Low when active.)
34	PTH00	I	RSWI (AUX)	REC out selector state setting input pin (AUX). (Low when active.)
35	TIO	I		Unused.
36	TI1	I		Unused.
37	P23	I	KEYIN (ADPT/TAPE3)	ADPT/TAPE3 key input pin (low when active). Enters the input mode during backup.
38	P22/PCL	I	KEYIN (SOURCE DIRECT)	SOURCE DIRECT key input pin (low when active). Enters the input mode during backup.
39	P21/PTO1	I	KEYIN (MUTING)	MUTING key input pin (low when active). Enters the input mode during backup.
40	P20/PTO0	I	KEYIN (LOUDNESS)	LOUDNESS key input pin (low when active). Enters the input mode during backup.
41	PO3/SI	I	KEYIN (SUBSONIC)	SUBSONIC key input pin (low when active).
42	PO2/SO	I	KEYIN (POWER)	POWER key input pin (low when active). Enters the input mode during backup.
43	PO1/SCK	I	REI A	ROTARY ENCODER A signal input pin. Enters the input mode during backup.
44	PO0/INT4	I	REI B	ROTARY ENCODER B signal input pin.
45	PI23	O	ADPT/TAPE23 LED	ADPT/TAPE3 LED control pin (low when active). No pull-up resistor is incorporated by a mask option. Enters the input mode during backup.
46	PI22	O	MUTING LED	MUTING LED control pin (low when active). No pull-up resistor is incorporated by a mask option. Enters the input mode during backup.
47	PI21	O	LOUDNESS LED	LOUDNESS LED control pin (low when active). No pull-up resistor is incorporated by a mask option. Enters the input mode during backup.
48	PI20	O	SUBSONIC LED	SUBSONIC LED control pin (low when active). No pull-up resistor is incorporated by a mask option. Enters the input mode during backup.
49	PI33	O	SOURCE DIRECT LED	SOURCE DIRECT LED control pin (low when active). No pull-up resistor is incorporated by a mask option. Enters the input mode during backup.
50	PI32	O	POWER LED	POWER LED control pin (low when active). No pull-up resistor is incorporated by a mask option. Enters the input mode during backup.
51	PI31	O	PHONO LED	PHONO LED control pin (low when active). No pull-up resistor is incorporated by a mask option. Enters the input mode during backup.
52	PI30	O	CD LED	CD LED control pin (low when active). No pull-up resistor is incorporated by a mask option. Enters the input mode during backup.

CIRCUIT DESCRIPTION

Pin No.	Pin name	I/O	Name	Description
53	PI43	O	TUNER LED	TUNER LED control pin (low when active). No pull-up resistor is incorporated by a mask option. Enters the input mode during backup.
54	PI42	O	AUX LED	AUX LED control pin (low when active). No pull-up resistor is incorporated by a mask option. Enters the input mode during backup.
55	PI41	O	TAPE2 LED	TAPE1 LED control pin (low when active). No pull-up resistor is incorporated by a mask option. Enters the input mode during backup.
56	PI40	O	TAPE1 LED	TAPE1 LED control pin (low when active). No pull-up resistor is incorporated by a mask option. Enters the input mode during backup.
57	NC			
58	Vdd			Microcomputer power supply pin.
59	P33	I/O	SDATA	Serial communication SDATA signal input/output pin. Enters the input mode during backup.
60	P32	I/O	SBUSY	Serial communication SBUSY signal input/output pin. Enters the input mode during backup.
61	P31	O	ADPT/TAPE3	ADPT/TAPE3 analog switch control signal output pin. ADPT/TAPE3 ON: High ADPT/TAPE3 OFF: low Outputs a low signal in the backup mode.
62	P30	O	ST1	FUNCTION IC TC9163N ST signal output pin for MUTING, SUBSONIC, SOURCE DIRECT, and LOUDNESS. Usually set low. Outputs a low signal in the backup mode.
63	P43	O	CK1	FUNKTION IC TC9163N CK signal output pin for MUTING, SUBSONIC, SOURCE DIRECT, and LOUDNESS. Usually set low. Outputs a low signal in the backup mode.
63	P43	O	DATA1	FUNCTION IC TC9163N DATA signal output pin for MUTING, SUBSONIC, SOURCE DIRECT, and LOUDNESS. Usually set low. Outputs a low signal in the backup mode.

ADJUSTMENT/REGLAGE/ABGLEICH

ADJUSTMENT

No.	ITEM	INPUT SETTINGS	OUTPUT SETTINGS	AMPLIFIER SETTING	ALIGNMENT POINTS	ALIGN FOR	FIG.
Unless otherwise specified, set the respective switches as follows: POWER: ON SPEAKER: B REC OUT: OFF SELECTOR: PHONO							
1	IDLE CURRENT	-	Connect a DC voltmeter across CP1 (L) CP2 (R) (X09-)	VOLUME: 0	VR1 (L) VR2 (R) (X09-)	15 mV (34 mA).	(a)

REGLAGES

N°	ITEM	REGLAGE DE L'ENTREE	REGLAGE DE LA SORTIE	REGLAGE DE L'AMPLIFICATEUR	POINTS DE L'ALIGNMENT	ALIGNER POUR	FIG.
Sauf indication contraire, régler comme suit les commandes respectives: POWER: ON SPEAKER: B REC OUT: OFF SELECTOR: PHONO							
1	COURANT DE POLARISATION	-	Connecter un voltmètre de CC SUR CP1 (G) CP2 (D) (X09-)	VOLUME: 0	VR1 (G) VR2 (D) (X09-)	15 mV (34 mA).	(a)

ABGLEICH

NR.	GEGENSTAND	EINGANGS-EINSTELLUNG	AUSANG-EINSTELLUNG	VORSTÄRKER-EINSTELLUNG	ABGLEICH-PUNKTE	ABGLEICHEN FÜR	ABB.
Wenn nicht anders angegeben, die einzelnen Schalter wie folgt einstellen: POWER: ON SPEAKER: B REC OUT: OFF SELECTOR: PHONO							
1	LEERLAUFSTROM	-	Einen Gleichspannungsmesser über CP1 (L) CP2 (R) anschließen. (X09-)	VOLUME: 0	VR1 (L) VR2 (R) (X09-)	15 mV (34 mA).	(a)

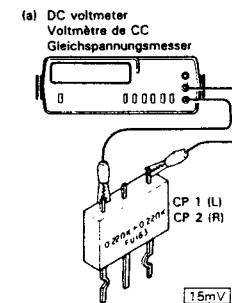

KA-4040R KA-4040R WIRING DIAGRAM

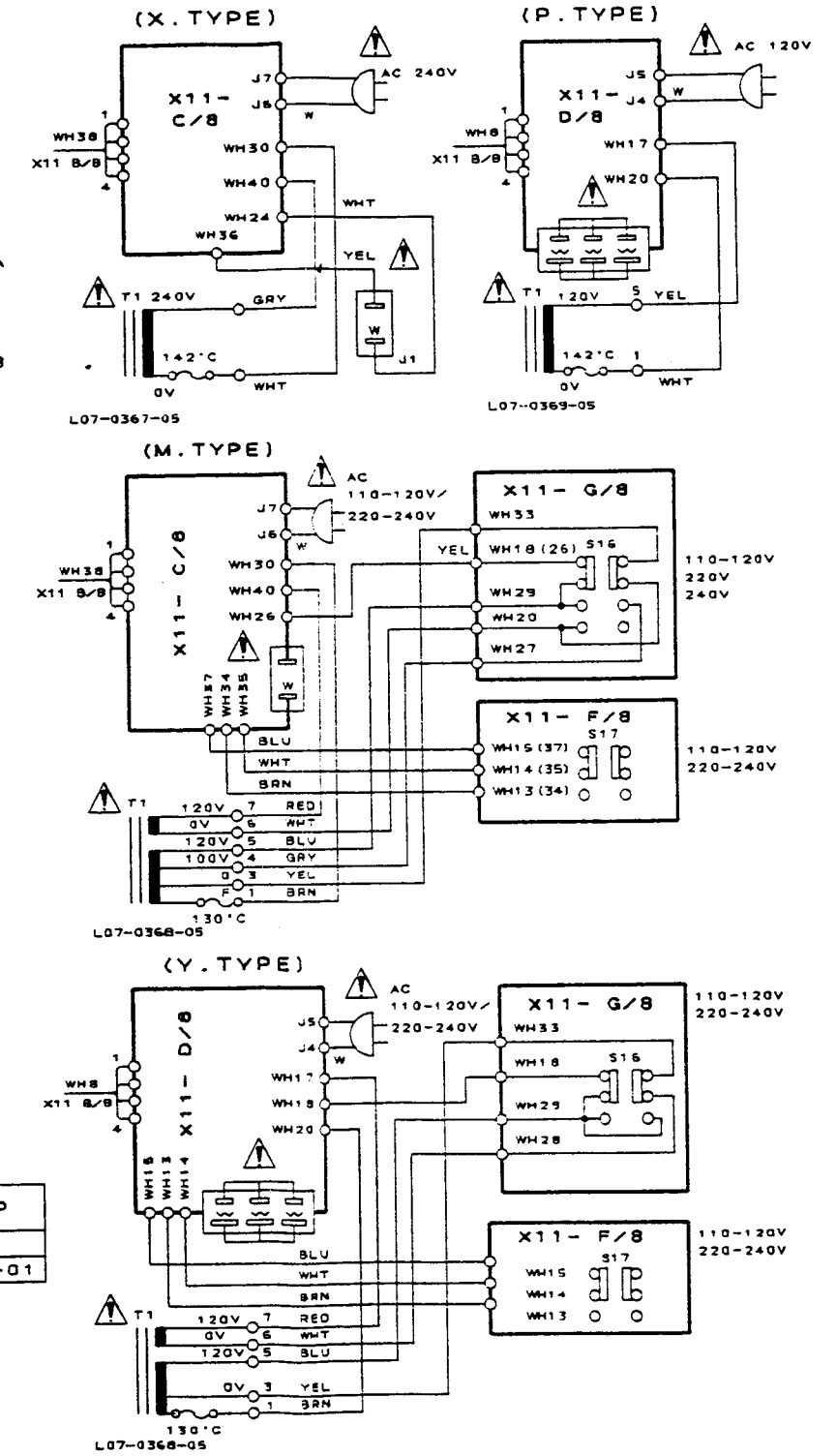
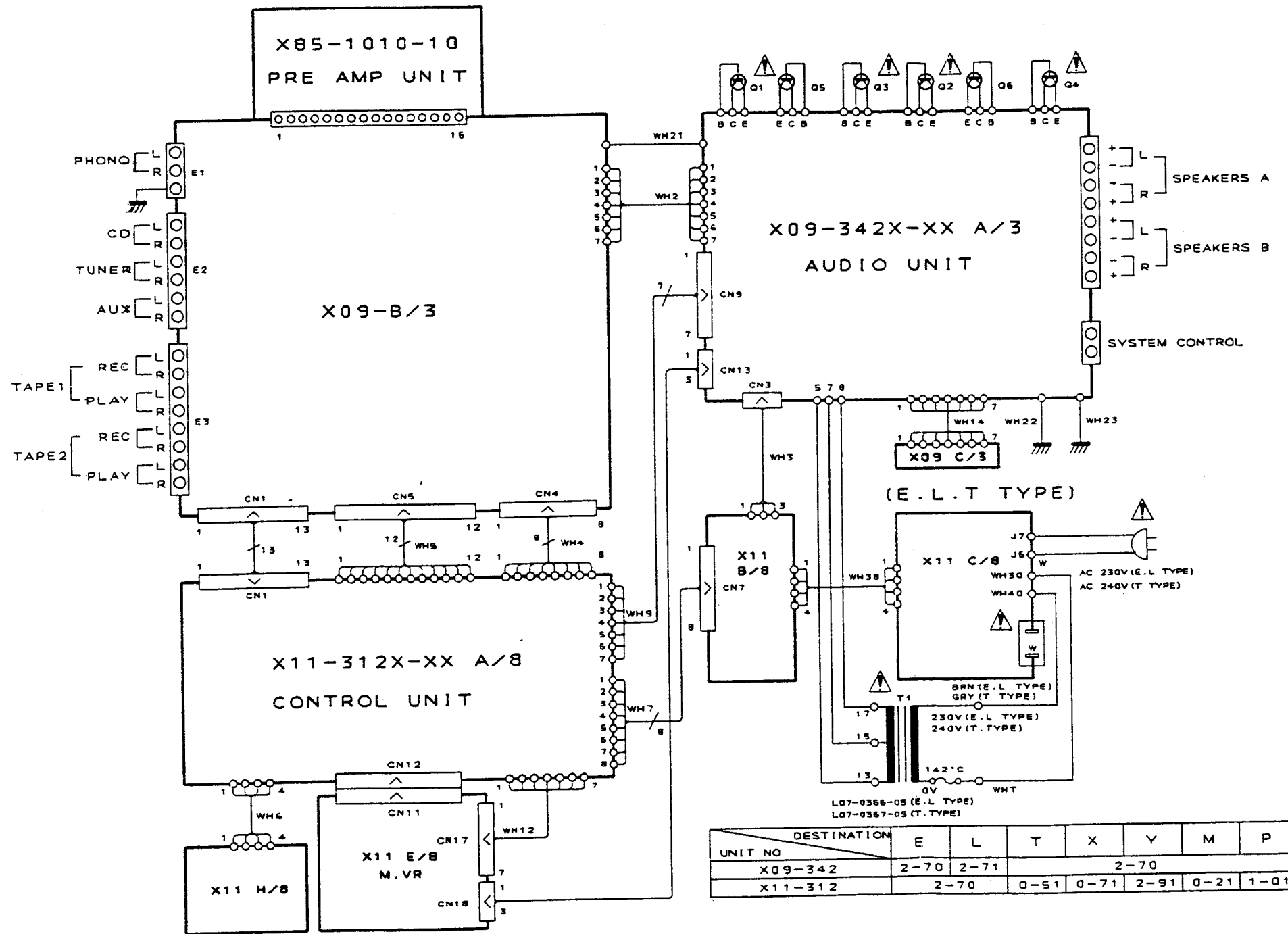

UNIT NO	DESTINATION							
	E	L	T	X	Y	M	P	
X09-342	2-70	2-71			2-70			
X11-312	2-70		0-51	0-71	2-91	0-21	1-01	

PC BOARD (Component side view)

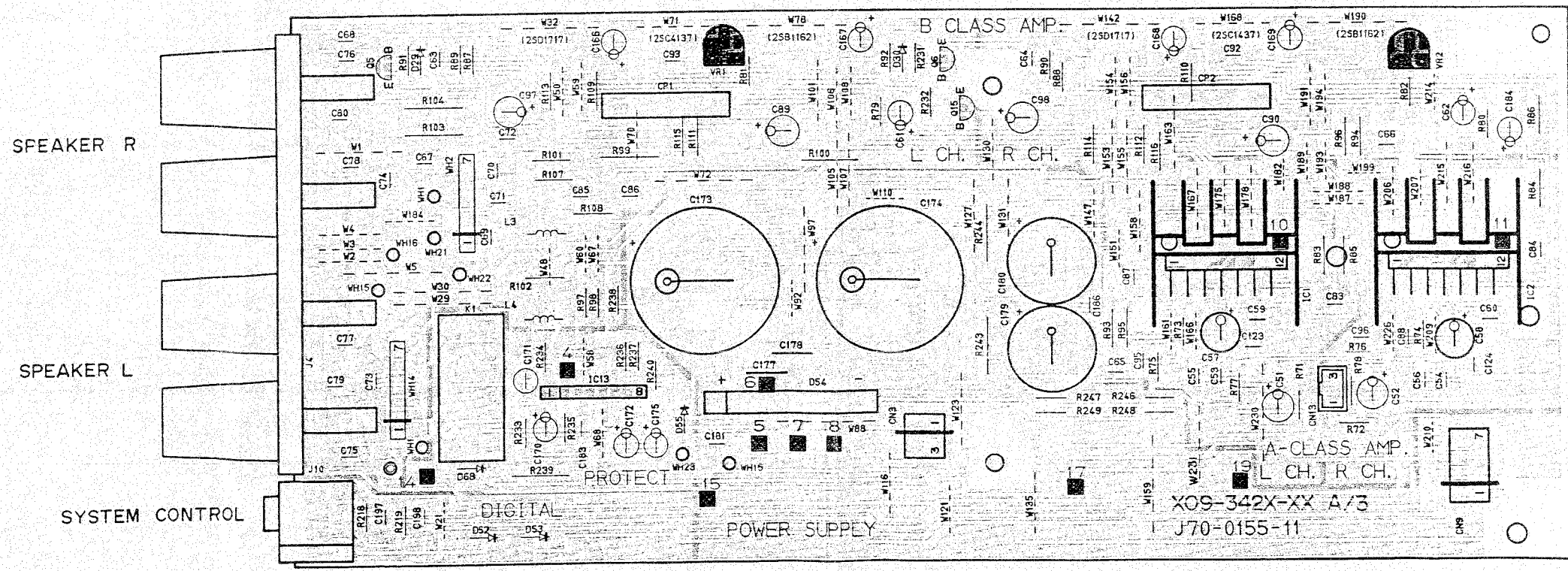
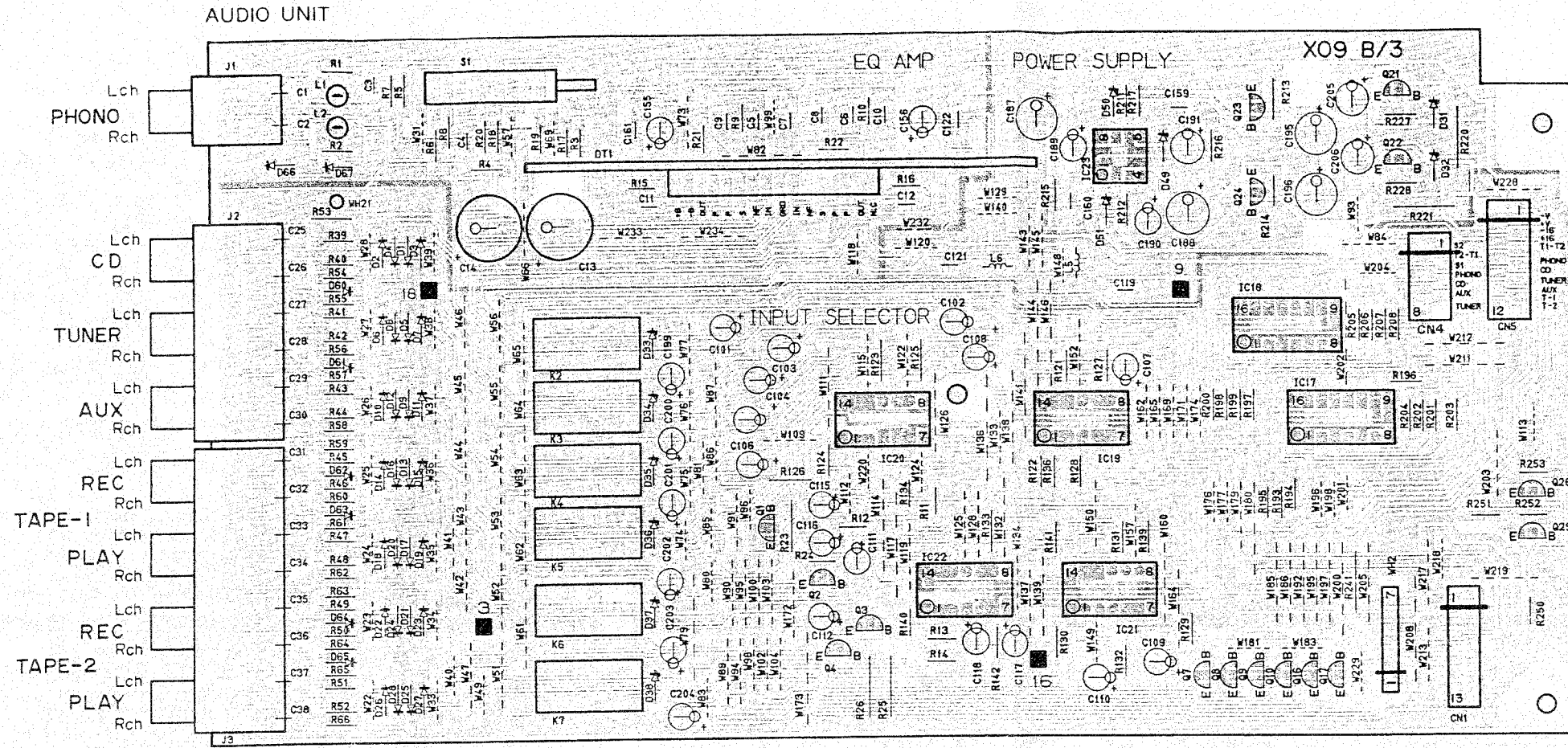

PC BOARD (Component side view)

CONTROL UNIT

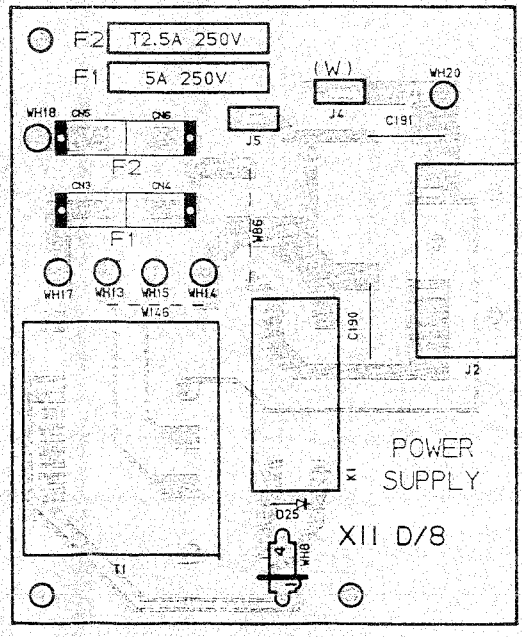
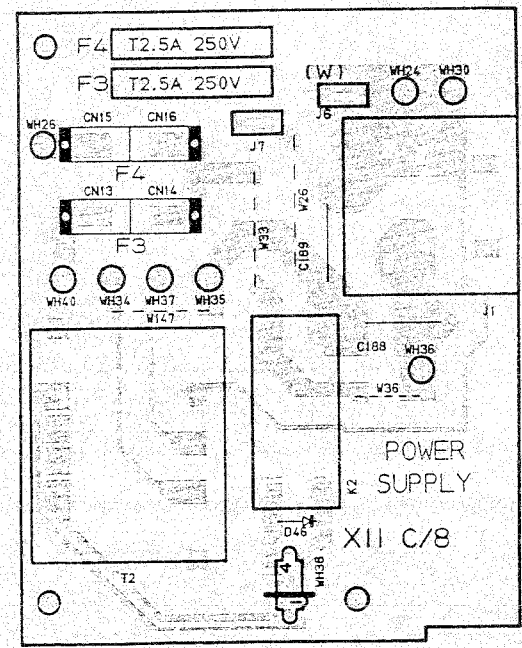
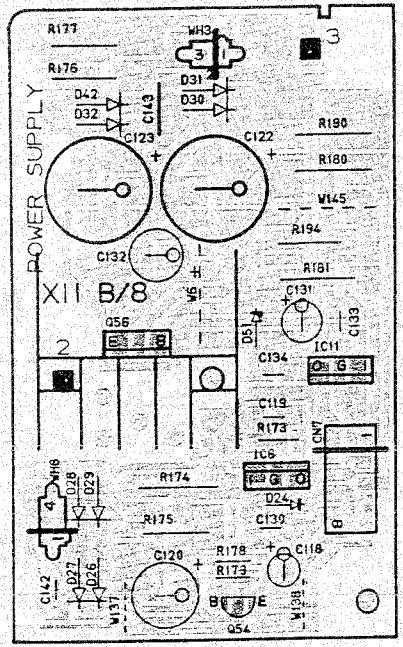
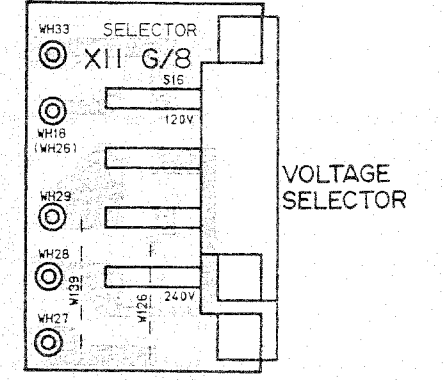
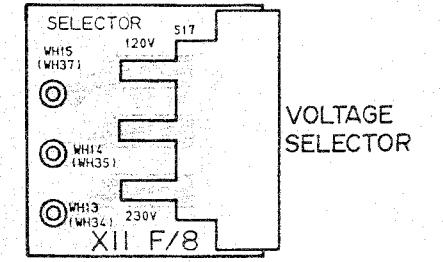
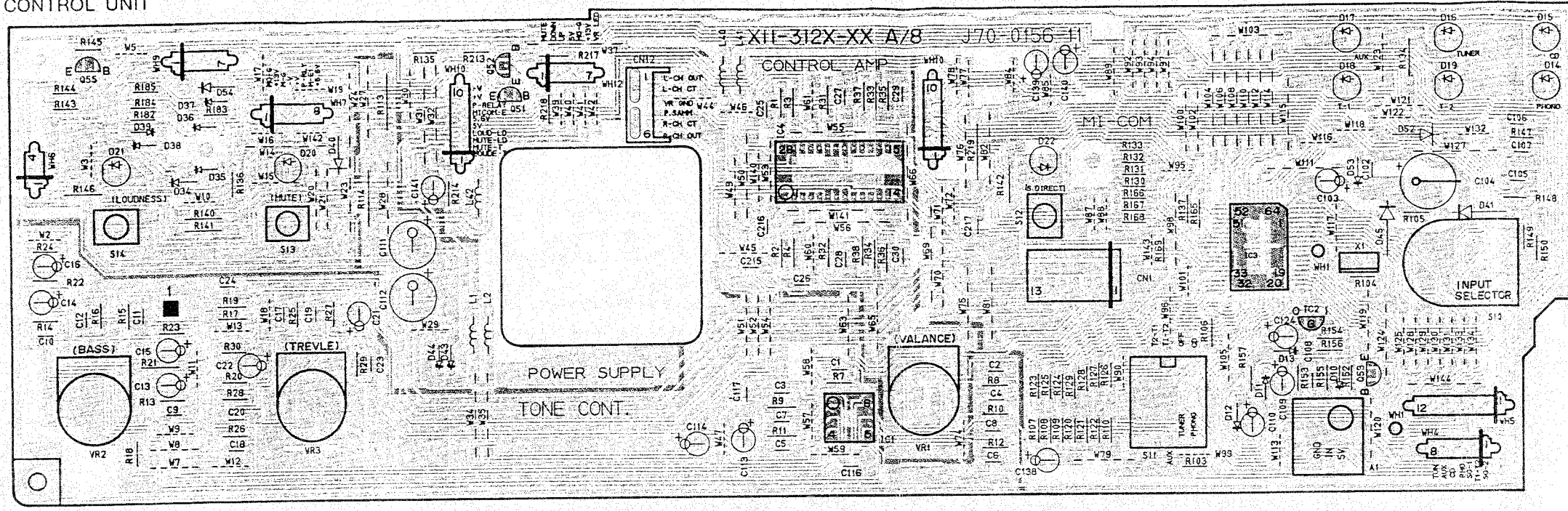

MASTER VOLUME

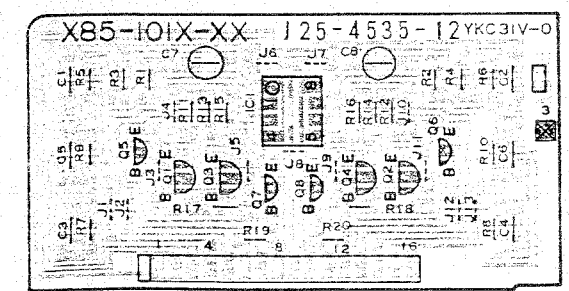
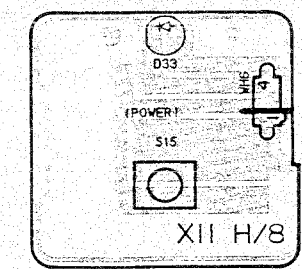
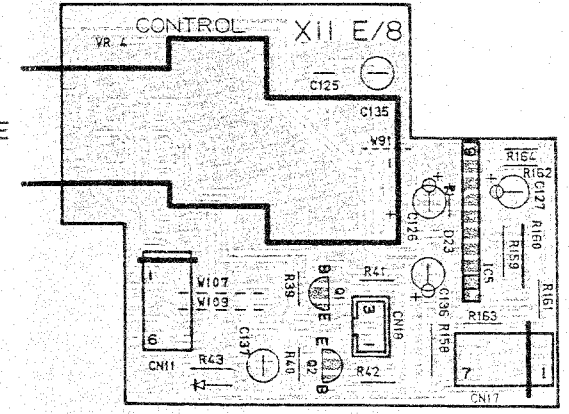

IC1-18 ON3134 Q25 DTA124ES O33-38 RD11ES (B)
 IC19-22 LC4966 Q26 DTC143TS O39-44 orHZ511N(B)
 IC23 NJM45650-D D1-20 1S5133 O49 RD5.1JS (B2)
 Q1-4 2SC2878(B) D61-68 1S5131 O50 orHZ55.13(B2)
 Q7-10,16,17 DTC143TS D50 RD15JS (B)
 Q22 2SB772(OP) D31-32 RD24ES (B) O51 orHZ5155(B)
 Q21,23,24 2SD882(OP) orHZ524N(B) RD20JS (B)
 orHZ5205(B)

(X11-312X-XX) (A/B)
 IC1 NJM45650-D O53 2SC1740 (QR) or 25C1
 IC2 PST529C O55 2SA933S (QR) or 25A1
 IC3 APD75104GF-778
 IC4 TC9163N O10-13, 34-39,41, 1S5133 or HSS104
 O52 DTA124ES or UN4112 45,53
 O51 DTC124ES or UN4212 014-22 B30-1291-05

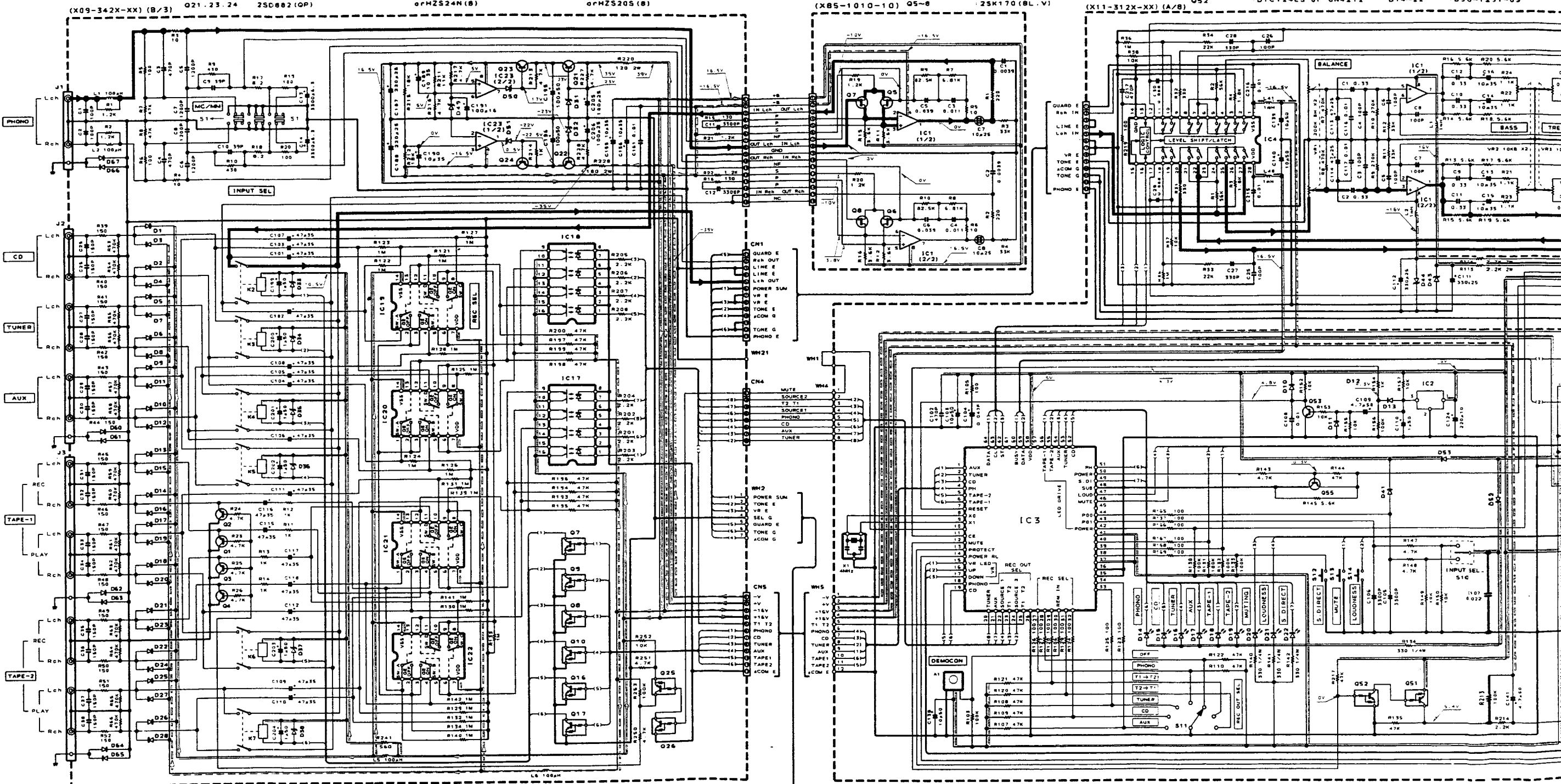

X09-342X-XX

COUNTRY	ABB.	UNIT NAME
EUROPE	E	X09-3422-70
SCANDINAVI	L	X09-3422-71
CANADA	P	X09-3422-70
AAFES EUROPE	Y	X09-3422-70
OTHER AREAS	M	X09-3422-70
AUSTRALIA	X	X09-3422-70
ENGLAND	T	X09-3422-70

X11-312X-XX

COUNTRY	ABB.	UNIT NAME	C/B	D/B	F/B	G/B	C188 189	C190 191	F1	F2	F3	F4	F5	T2
SCANDINAVI&EUROPE	E,L	X11-3122-70	YES	NO	NO	NO	NO	NO	NO	NO	T2.5A 250V	T2.5A 250V	NO	L01-7613-05
CANADA	P	X11-3121-01	NO	YES	NO	NO	NO	C91-0971-05	5A 125V	NO	NO	NO	NO	L01-7651-05
AAFES EUROPE	Y	X11-3122-91	NO	YES	YES	YES	YES	NO	C91-1421-05	T2.5A 250V	T2.5A 250V	NO	NO	L01-7653-05
OTHER AREAS	M	X11-3120-21	YES	NO	YES	YES	YES	NO	NO	NO	T2.5A 250V	T2.5A 250V	NO	L01-7653-05
AUSTRALIA	X	X11-3120-71	YES	NO	NO	NO	NO	C91-1421-05	NO	NO	T2.5A 250V	NO	NO	L01-7657-05
ENGLAND	T	X11-3120-51	YES	NO	NO	NO	NO	C91-1421-05	NO	NO	T2.5A 250V	NO	NO	L01-7657-05

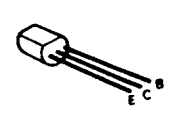

2SA992
 2SC1845
 2SC2003
 2SC2878

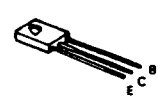

2SB772
 2SD882

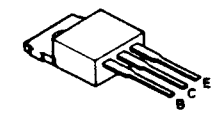

2SD1266

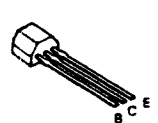

DTA124ES
 DTC124ES
 DTC143TS
 UN4112
 2SA933S
 2SC1740S

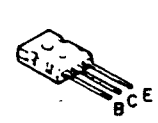

2SB1162BD*5
 2SD1717BD*5

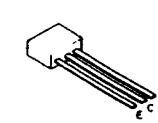

UN4212
 2SA1309A
 2SC3311A

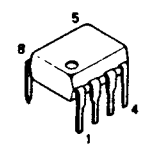

NJM456 OD-N
 NJM456 5D-D

(X11-312X-XX) (A/B)
 IC1 NJM4560D-N
 IC2 PST529C
 IC3 PD75104GF-778
 IC4 TC9163N
 Q51 DTA124ES or UN4112
 Q52 DTC124ES or UN4212
 Q53 25C1740 (QR) or 25C1740S (Q.R.)
 Q55 25A933S (QR) or 25A1309A (Q.R.)
 D10-13. 15S133 or HSS104
 34-39.41. 45.53
 D14-22 030-1291-05
 D40.52.42 55608B
 D43.44 RD16ES (B2)
 or MZS16N (B2)
 D54 15S131
 or HSS104A
 IC5 TA8409S
 Q1.2 25C2078 (B)
 D23 RD2.7E5 (B)
 (X11-) (E/B)
 (X09-) (C/3)

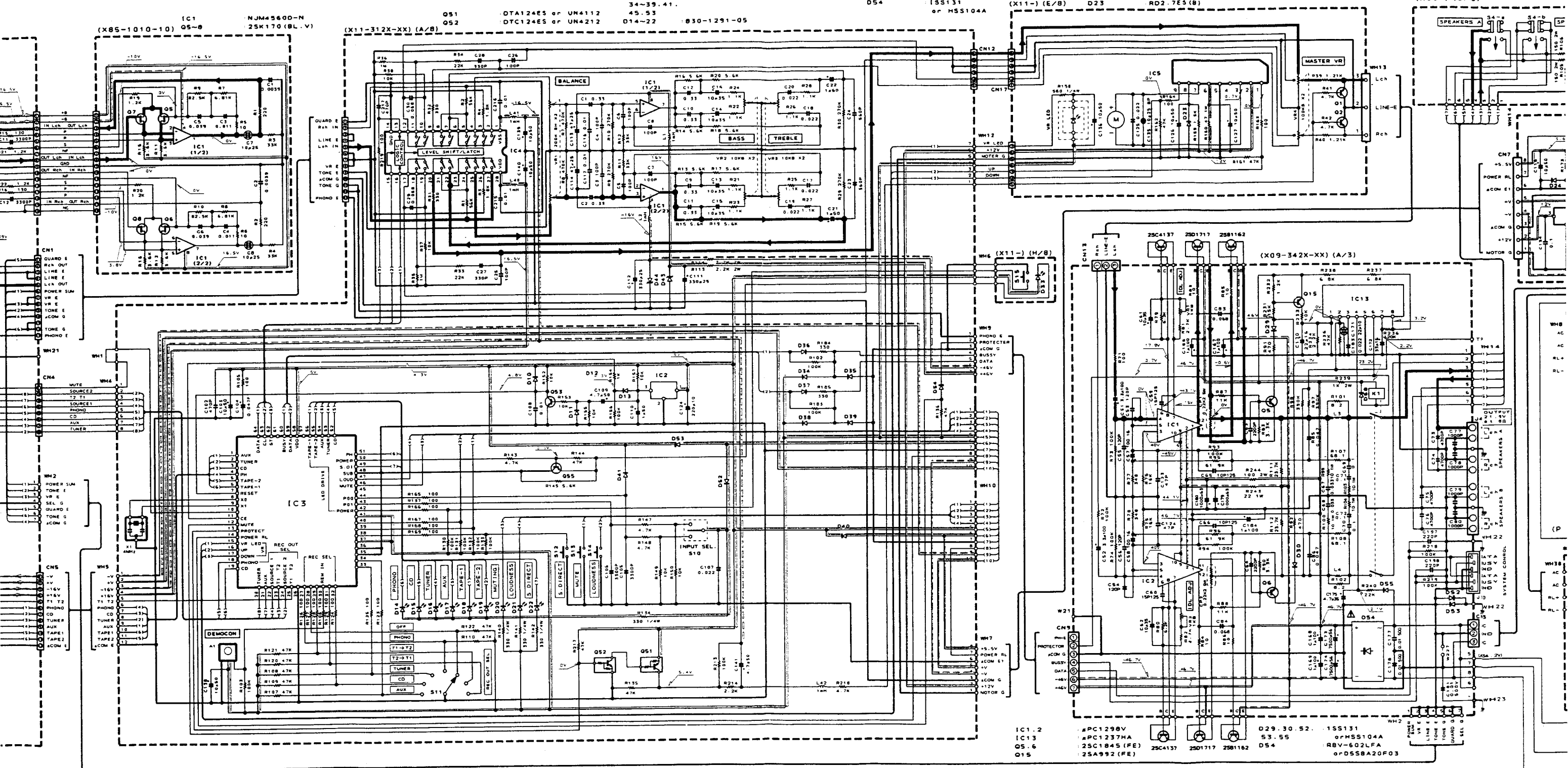

UNIT NAME	COUNTRY	ABB.	UNIT NAME	C/B	D/B	F/B	G/B	C188 189	C190 191	F1	F2	F3	F4	T1	T2	S16	WH15 14 15 18	WH16 19	WH17 20	WH24	WH26 34 35 37	WH27	WH29 28 33	WH30 40	WH36	WH146	W36	W139	W147	J1	
9-1422-70	SCANDINAVIA/EUROPE	E.L.	X11-3122-70	YES	NO	NO	NO	C91-1421-05	NO	NO	NO	T2.5A 250V	T2.5A 250V	NO	L01-7653-05	NO	NO	NO	NO	NO	NO	NO	NO	YES	YES	YES	NO	NO	NO	NO	
9-1422-71	CANADA	P	X11-3121-01	NO	NO	NO	NO	C91-0971-05	SA 125V	NO	NO	NO	NO	NO	L01-7651-05	NO	NO	NO	YES	NO	NO	NO	NO	NO	NO	NO	NO	NO	NO	NO	
9-1422-70	AFES EUROPE	Y	X11-3122-91	NO	YES	YES	YES	C91-1421-05	T2.5A 250V	T2.5A 250V	NO	NO	NO	NO	L01-7653-05	S31-2322-05	NO	NO	NO	NO	NO	YES	YES	YES	NO	NO	NO	NO	NO	NO	
9-1422-70	OTHER AREAS	M	X11-3120-21	YES	NO	YES	YES	NO	NO	NO	NO	T2.5A 250V	T2.5A 250V	NO	L01-7653-05	NO	NO	NO	NO	NO	NO	NO	NO	YES	YES	YES	NO	NO	NO	NO	
9-1422-70	AUSTRALIA	X	X11-3120-71	YES	NO	NO	NO	C91-1421-05	NO	NO	NO	T2.5A 250V	NO	NO	L01-7657-05	NO	NO	NO	NO	NO	NO	NO	NO	NO	NO	NO	NO	NO	NO	NO	
9-1422-70	ENGLAND	T	X11-3120-51	YES	NO	NO	NO	C91-1421-05	NO	NO	NO	T2.5A 250V	NO	NO	L01-7657-05	NO	NO	NO	NO	NO	NO	NO	NO	NO	NO	NO	NO	NO	NO	NO	NO

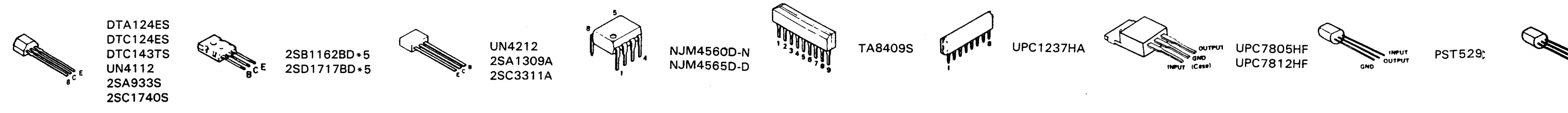

2.42 55688B
RD16ES (B2)
or HZS16N (B2)
ISS131
or HSS104A

IC5 TA84095
O1.2 25C2878 (B)
RD2.7ES (B)

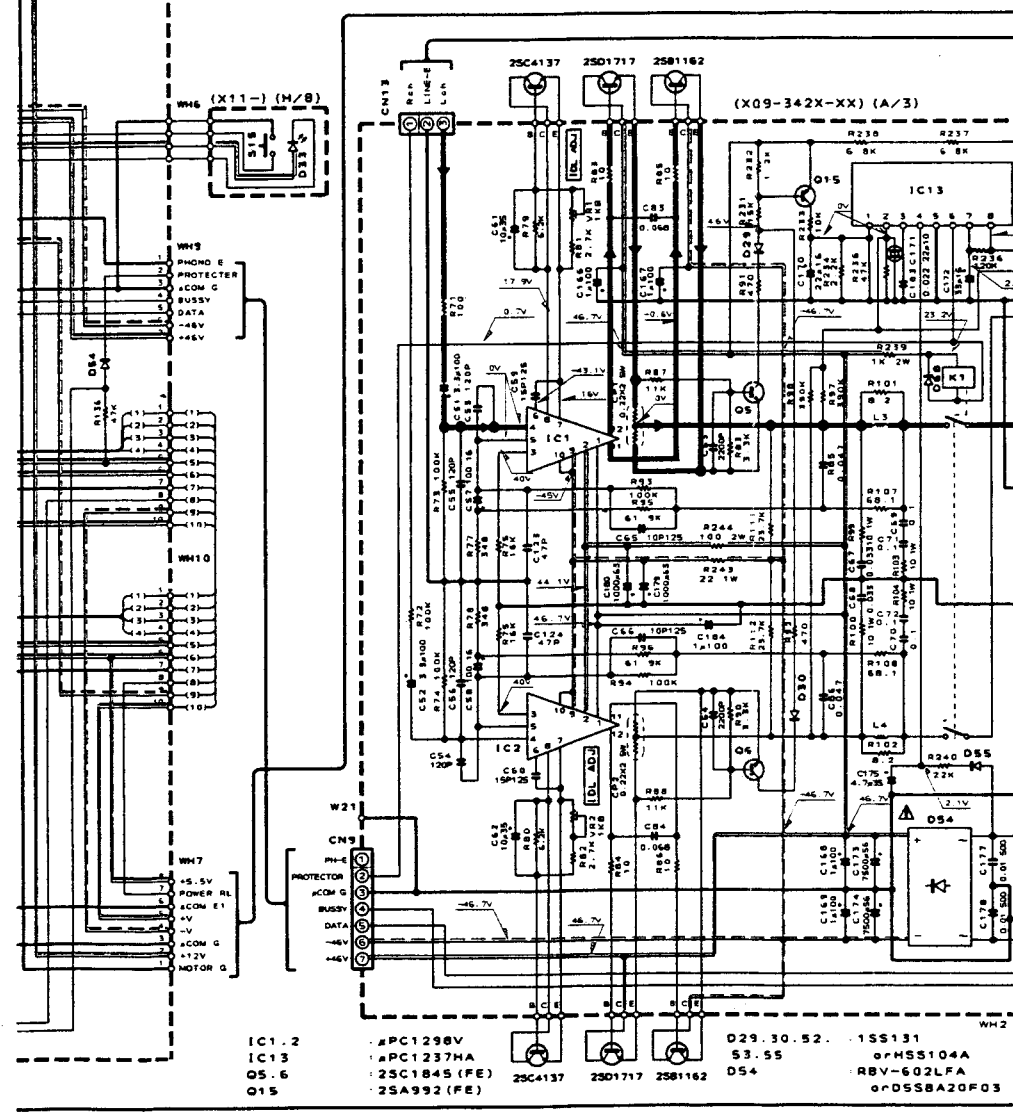
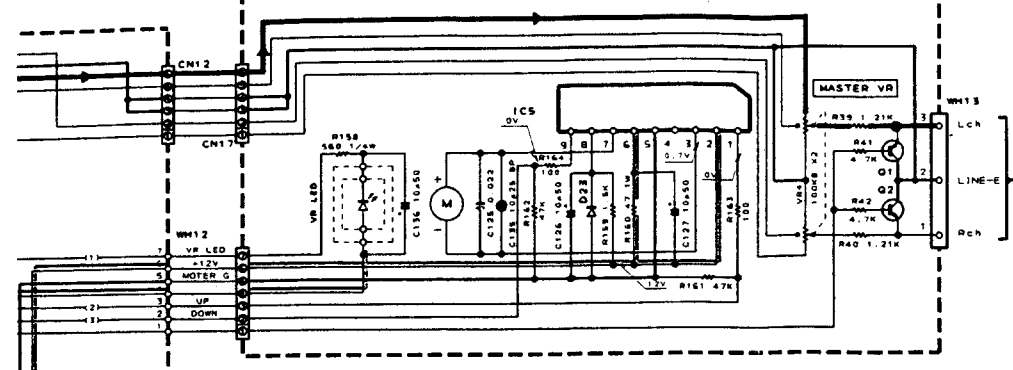

18	WH16	19	WH17	20	WH24	26	34	35	37	WH27	WH29	28	33	WH30	40	WH36	WH146	W36	W139	W147	J1	
	NO	NO	NO	NO	NO	NO	NO	NO	NO	NO	NO	NO	NO	NO	NO	NO	NO	NO	NO	NO	NO	NO
	NO	YES	NO	NO	NO	NO	NO	NO	NO	NO	NO	NO	NO	NO	NO	NO	NO	NO	NO	NO	NO	NO
	YES	YES	NO	NO	NO	NO	NO	NO	NO	NO	NO	NO	NO	NO	NO	NO	NO	NO	NO	NO	NO	NO
	YES	NO	NO	YES	YES	YES	YES	NO	NO	YES	NO	NO	YES	NO	NO	YES	NO	NO	NO	NO	YES	YES
	NO	NO	YES	NO	NO	NO	NO	NO	NO	NO	NO	NO	NO	NO	NO	NO	NO	NO	NO	NO	NO	NO
	NO	NO	NO	NO	NO	NO	NO	NO	NO	NO	NO	NO	NO	NO	NO	NO	NO	NO	NO	NO	NO	NO

(X09-) (C/3)

(X11-) (B/B)

IC6 TA78055
or PC7805HF
or PC7812HF
or TA7812S

O54 25C2003 (LK)
O56 25D1266 (OR)

O24 15S133
or HSS104

O26-32.42 55688B
O51 RD24ES (B)
or HZS24N (B)

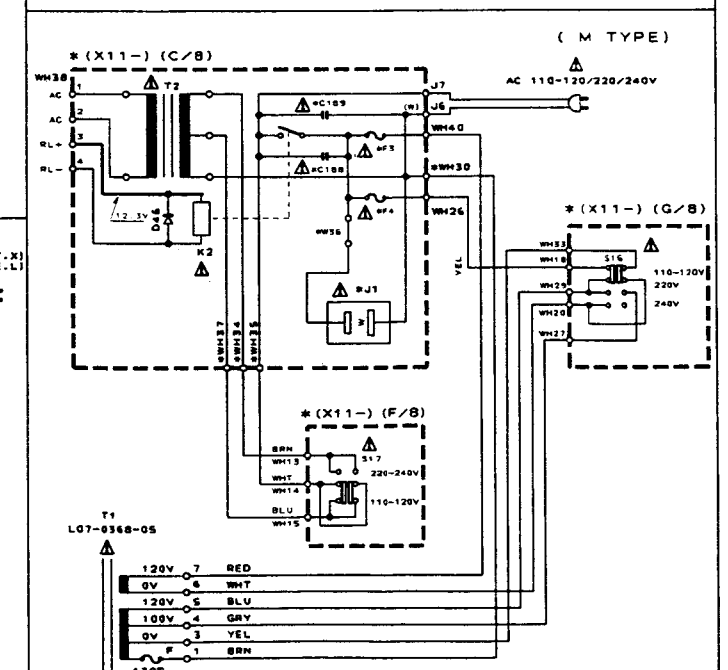
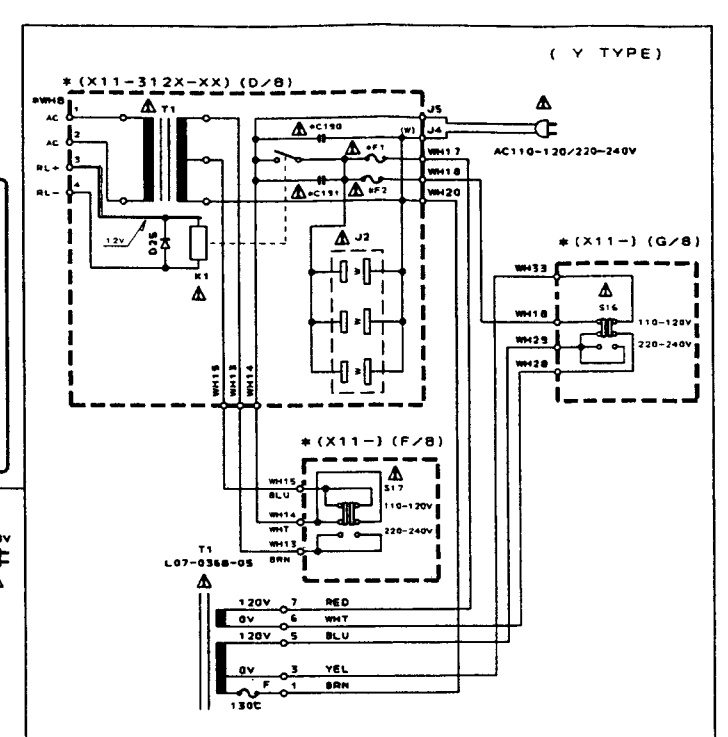
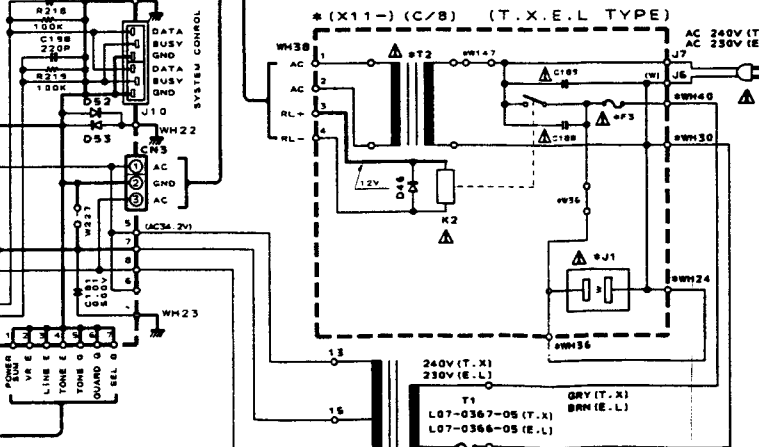
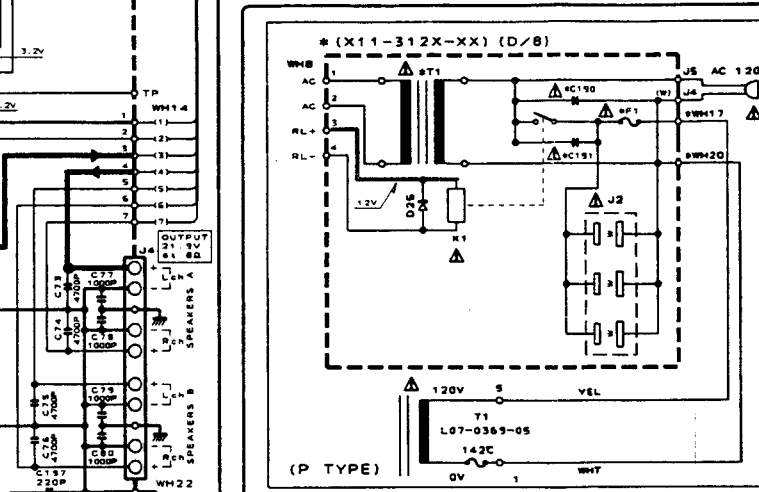
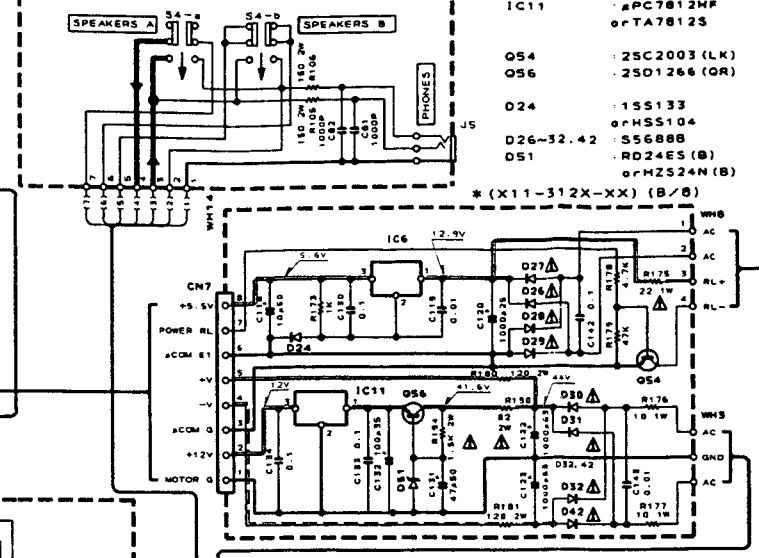

DC voltages are as measured with a high impedance voltmeter with no signal input. Values may vary slightly due to variations between individual instruments or and units.

Les tensions c.c. doivent être mesurées avec un voltmètre à haute impédance sans signal d'entrée. Les valeurs peuvent différer légèrement du fait des variations inhérentes aux appareils et aux instruments de mesure individuels.

Die angegebenen Gleichspannungswerte wurden mit einem hochohmigen Spannungsmesser ohne Eingangssignal gemessen. Dabei schwanken die Meßwerte aufgrund von Unterschieden zwischen einzelnen Instrumenten oder Geräten u U. geringfügig.

CAUTION: For continued safety, replace safety critical components only with manufacturer's recommended parts (refer to parts list). Δ Indicates safety critical components. To reduce the risk of electric shock, leakage-current or resistance measurements shall be carried out (exposed parts are acceptably insulated from the supply circuit) before the appliance is returned to the customer.

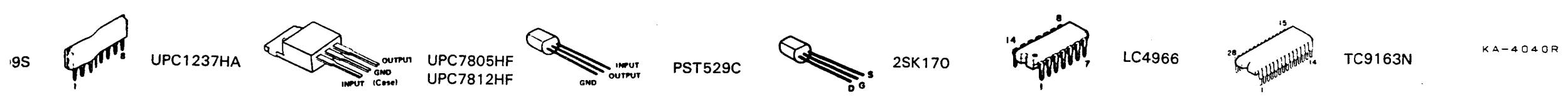
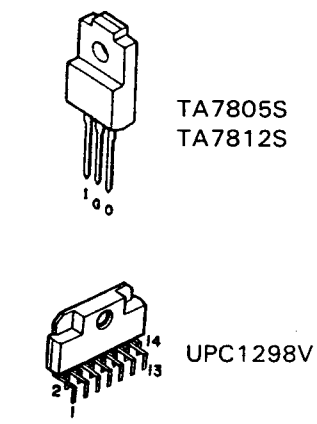

KA-4040R
KENWOOD

* New Parts
Parts without Parts No. are not supplied.
Les articles non mentionnés dans le Parts No. ne sont pas fournis.
Teile ohne Parts No. werden nicht geliefert.

No. 1

Table with columns: Ref. No., Address, New Parts, Parts No., Description, Destination, Remarks. Includes sub-section KA-4040R.

L:Scandinavia K:USA P:Canada
Y:PX(Far East, Hawaii) T:England E:Europe
Y:AFES(Europe) X:Australia M:Other Areas

indicates safety critical components.

DESTINATION LIST

Table with columns: Destination, Location (E, L, T, X, Y, M, P).

AUDIO UNIT

Table with columns: Part No., Location (E, T, X, Y, M, P).

CONTROL UNIT

Table with columns: Part No., Location (M, T, X, P, E, L, Y).

PRE AMPLIFIER UNIT

Table with columns: Part No., Location (E, L, T, X, Y, M, P).

PARTS LIST

KA-4040R

KA-4040R

* New Parts
Parts without Parts No. are not supplied.
Les articles non mentionnés dans le Parts No. ne sont pas fournis.
Teile ohne Parts No. werden nicht geliefert.

No. 2

Table with columns: Ref. No., Address, New Parts, Parts No., Description, Destination, Remarks. Includes sub-section AUDIO UNIT (X09-3422-70).

L:Scandinavia K:USA P:Canada
Y:PX(Far East, Hawaii) T:England E:Europe
Y:AFES(Europe) X:Australia M:Other Areas

indicates safety critical components.

* New Parts
Parts without Parts No. are not supplied.
Les articles non mentionnés dans le Parts No. ne sont pas fournis.
Teile ohne Parts No. werden nicht geliefert.

No. 3

Table with columns: Ref. No., Address, New Parts, Parts No., Description, Destination, Remarks.

L:Scandinavia K:USA P:Canada
Y:PX(Far East, Hawaii) T:England E:Europe
Y:AFES(Europe) X:Australia M:Other Areas

indicates safety critical components.

PARTS LIST

KA-4040R KA-4040R

EXPLODED VIEW

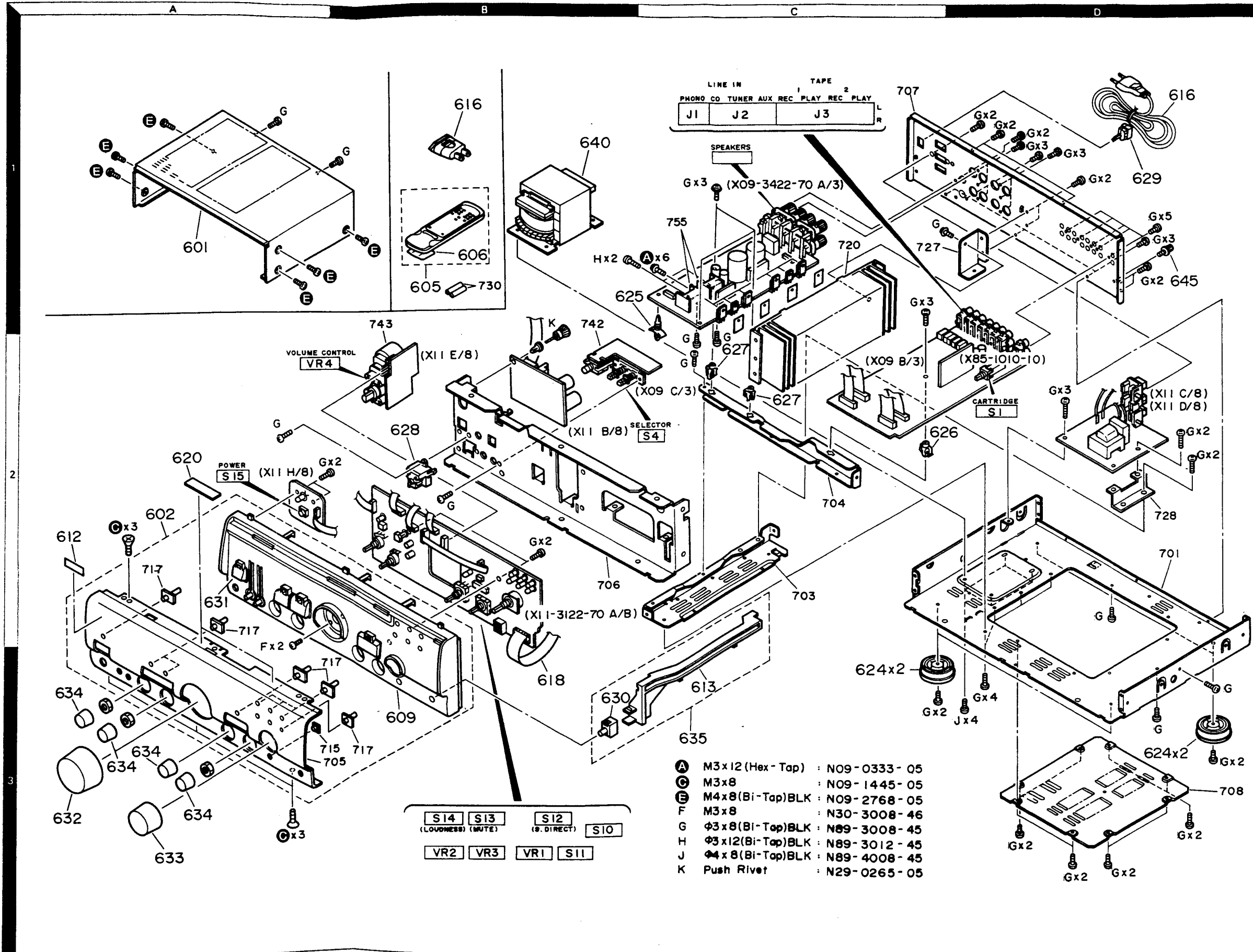

* New Parts

Parts without Parts No. are not supplied

Les articles non mentionnés dans le Parts No. ne sont pas fournis

Teile ohne Parts No. werden nicht geliefert.

No. 4

Ref. No. 参照番号	Address 位置	New Parts 新	Parts No. 部品番号	Description 部品名 / 規格	Desti- nation 仕	Re- marks 備考
D50			HZS15S(B)	ZENER DIODE		
D50			RD15JS(B)	ZENER DIODE		
D51			HZS20S(B)	ZENER DIODE		
D51			RD20JS(B)	ZENER DIODE		
D52, 53			HSS104A	DIODE		
D52, 53			1SS131	DIODE		
D54			D5SBA20F03	DIODE		
D54			RBV-602LFA	DIODE		
D55			HSS104A	DIODE		
D55			1SS131	DIODE		
D60 -68			HSS104A	DIODE		
D60 -68			1SS131	DIODE		
IC1, 2			UPC1298V	IC(POWER AMP DRIVER)		
IC13		*	UPC1237HA	IC(POWER AMP)		
IC17, 18			ON3134	IC(OPTICAL ISOLATOR)		
IC19-22			LC4966	IC(CHMOS LOGIC BILATERAL SW)		
IC23			NJM4565D-D	IC(OP AMP X2)		
Q1 -4			2SC2878(B)	TRANSISTOR		
Q5, 6			2SC1845(F,E)	TRANSISTOR		
Q7 -10			DTC143TS	DIGITAL TRANSISTOR		
Q15			2SA992(F,E)	TRANSISTOR		
Q16, 17			DTC143TS	DIGITAL TRANSISTOR		
Q21			2SD882(Q,P)	TRANSISTOR		
Q22			2SB772(Q,P)	TRANSISTOR		
Q23, 24			2SD882(Q,P)	TRANSISTOR		
Q25			DTA124ES	DIGITAL TRANSISTOR		
Q26			DTC143TS	DIGITAL TRANSISTOR		
CONTROL UNIT (X11-3121-XX)						
D14 -22			B30-1291-05	LED		
D33			B30-1291-05	LED		
C1, 2			CF92FV1H334J	MF 0.33UF J		
C3 -8			CF92FV1H101K	MF 100PF K		
C9 -12			CF92FV1H334J	MF 0.33UF J		
C13 -16			CE04KW1H100M	ELECTRO 10UF 35WV		
C17 -20			CF92FV1H223J	MF 0.022UF J		
C21, 22			CE04KW1H010M	ELECTRO 1.0UF 50WV		
C23, 24			CF92FV1H561J	MF 560PF J		
C25, 26			CF92FV1H101K	MF 100PF K		
C27, 28			CF92FV1H331K	MF 330PF K		
C29, 30			CF92FV1H683J	MF 0.068UF J		
C102			CF92FV1H471J	MF 470PF J		
C103			CE04KW1H100M	ELECTRO 10UF 50WV		
C104			C90-1827-05	BACKUP 0.047F 5.5WV		
C105, 106			CK45FB1H332K	CERAMIC 3300PF K		
C107			CF92FV1H223J	MF 0.022UF J		
C108			CF92FV1H103J	MF 0.010UF J		
C109			CE04KW1H4R7M	ELECTRO 4.7UF 50WV		
C110			CE04KW1H010M	ELECTRO 1.0UF 50WV		
C111, 112			CE04KW1E331M	ELECTRO 330UF 25WV		
C113, 114			CE04KW1E470M	ELECTRO 47UF 25WV		
C116, 117			CF92FV1H103J	MF 0.010UF J		
C118			CE04KW1H100M	ELECTRO 10UF 50WV		
C119			CF92FV1H103J	MF 0.010UF J		
C120			CE04KW1E102M	ELECTRO 1000UF 25WV		

L:Scandinavia

K:USA

P:Canada

Y:PX(Far East, Hawaii)

T:England

E:Europe

Y:AAFES(Europe)

X:Australia

M:Other Areas

△ indicates safety critical components

* New Parts

Parts without Parts No. are not supplied

Les articles non mentionnés dans le Parts No. ne sont pas fournis

Teile ohne Parts No. werden nicht geliefert.

No. 5

Ref. No. 参照番号	Address 位置	New Parts 新	Parts No. 部品番号	Description 部品名 / 規格	Desti- nation 仕	Re- marks 備考
C122, 123			CE04KW1J102M	ELECTRO 1000UF 63WV		
C124			CE04KW1A221M	ELECTRO 220UF 10WV		
C125			CF92FV1H223J	MF 0.022UF J		
C126, 127			CE04KW1H100M	ELECTRO 10UF 50WV		
C130			CF92FV1H104J	MF 0.10UF J		
C131			CE04KW1H470M	ELECTRO 47UF 50WV		
C132			CE04KW1H101M	ELECTRO 100UF 35WV		
C133, 134			CF92FV1H104J	MF 0.10UF J		
C135			C90-1332-05	NP-ELEC 10UF 25WV		
C136			CE04KW1H100M	ELECTRO 10UF 50WV		
C138-140			CE04KW1H100M	ELECTRO 10UF 50WV		
C141			CE04KW1H4R7M	ELECTRO 4.7UF 50WV		
C142			CK45FF1H103Z	CERAMIC 0.010UF Z		
C143			CK45FE2H103P	CERAMIC 0.010UF P		
△ C188, 189			C91-1421-05	FILM 0.01UF 250AC	ELTXM	
△ C190, 191			C91-0971-05	FILM 0.01UF 250WV	P	
△ C190, 191			C91-1421-05	FILM 0.01UF 250AC	Y	
△ C215, 216			CF92FV1H103J	MF 0.010UF J		
△ C217			CK45FB1H471K	CERAMIC 470PF K		
△ J1			E03-0108-05	AC OUTLET		
△ J1			E03-0109-05	AC OUTLET	ELM	
△ J2			E03-0111-05	AC OUTLET	YP	
△ F1			F04-5022-05	FUSE (UL) (125V 5A UL)	P	
△ F1, 2			F05-2525-05	FUSE (SEMKO) (250V T2.5A)	Y	
△ F3			F05-2525-05	FUSE (SEMKO) (250V T2.5A)	TX	
△ F3, 4			F05-2525-05	FUSE (SEMKO) (250V T2.5A)	ELM	
△ CN3 -6			J13-0075-05	FUSE CLIP	Y	
△ CN3, 4			J13-0075-05	FUSE CLIP	P	
△ CN13-16			J13-0075-05	FUSE CLIP	ELM	
△ CN13, 14			J13-0075-05	FUSE CLIP	TX	
△ L1, 2			L40-1021-14	SMALL FIXED INDUCTOR(1.0MH,K)	P	
△ L40 -42			L40-1021-14	SMALL FIXED INDUCTOR(1.0MH,K)	Y	
△ T1			L01-7651-05	POWER TRANSFORMER	P	
△ T1			L01-7653-05	POWER TRANSFORMER	Y	
△ T2			L01-7653-05	POWER TRANSFORMER	ELM	
△ X1			L01-7657-05	POWER TRANSFORMER	TX	
			L78-0267-05	RESONATOR 4MHz		
G	2A, 3B		N89-3008-45	BINDING HEAD TAPTITE SCREW		
H	2A, 3B		N89-3012-45	BINDING HEAD TAPTITE SCREW		
R39, 40			RN14BK2C1211FTS	RN 1.21K F 1/6W		
R113, 114			RS14DB3D222JTE	FL-PROOF RS 2.2K J 2W		
R160			RS14DB3A470JTE	FL-PROOF RS 47 J 1W		
R174			RS14DB3D470JTE	FL-PROOF RS 47 J 2W		
R175			RS14DB3A220JTE	FL-PROOF RS 22 J 1W		
R176, 177			RS14DB3A100JTE	FL-PROOF RS 10 J 1W		
R180, 181			RS14DB3D121JTE	FL-PROOF RS 120 J 2W		
R190			RS14DB3D820JTE	FL-PROOF RS 82 J 2W		
R191			RD14AB2E120JTS	FL-PROOF RD 12 J 1/4W		
R194			RS14DB3A152JTE	FL-PROOF RS 1.5K J 1W		
VR1		*	R06-5191-05	POTENTIOMETER BALANCE		
VR2, 3		*	R06-3061-05	POTENTIOMETER BASS, TREBLE		
VR4		*	R29-5058-05	POTENTIOMETER MASTER VOLUME		

L:Scandinavia

K:USA

P:Canada

Y:PX(Far East, Hawaii)

T:England

E:Europe

Y:AAFES(Europe)

X:Australia

M:Other Areas

△ indicates safety critical components

PARTS LIST

KA-4040R

× New Parts

Parts without Parts No. are not supplied.

Les articles non mentionnés dans le Parts No. ne sont pas fournis.

Teile ohne Parts No. werden nicht geliefert.

No. 6

Ref. No. 参照番号	Address 位置	New Parts 新	Parts No. 部品番号	Description 部品名 / 規格	Desti- nation 仕向	Re- marks 備考
K1			SS1-1052-05	MAGNETIC RELAY	YP	
K2			SS1-1052-05	MAGNETIC RELAY	ELTXM	
S11		*	S60-0009-05	ROTARY SWITCH RECOUT SELECTOR		
S12 -15			S40-1064-05	PUSH SWITCH	M	
S16			S31-2322-05	SLIDE SWITCH VOLTAGE SELECT		
S16 ,17			S62-0001-05	SLIDE SWITCH VOLTAGE SELECT	Y	
S17			S62-0001-05	SLIDE SWITCH VOLTAGE SELECT	M	
S10		*	T99-0521-05	ROTARY ENCODER INPUT SELECTOR		
D10 -13			HSS104	DIODE		
D10 -13			1SS133	DIODE		
D23			HZS2.7N(B)	ZENER DIODE		
D23			RD2.7ES(B)	ZENER DIODE		
D24			HSS104	DIODE		
D24			1SS133	DIODE	YP	
D25			HSS104A	DIODE	YP	
D25			1SS131	DIODE		
D26 -32			S56888	DIODE		
D34 -39			HSS104	DIODE		
D34 -39			1SS133	DIODE		
D40			S56888	DIODE		
D41			HSS104	DIODE		
D41			1SS133	DIODE		
D42			S56888	DIODE		
D43 ,44			HZS16N(B2)	ZENER DIODE		
D43 ,44			RD16ES(B2)	ZENER DIODE		
D45			HSS104	DIODE		
D45			1SS133	DIODE		
D46			HSS104A	DIODE	ELTXM	
D46			1SS131	DIODE	ELTXM	
D51			HZS24N(B)	ZENER DIODE		
D51			RD24ES(B)	ZENER DIODE		
D52			S56888	DIODE		
D53			HSS104	DIODE		
D53			1SS133	DIODE		
D54			HSS104A	DIODE		
D54			1SS131	DIODE		
IC1			NJM4560D-D	IC(OP AMP X2)		
IC2			PST529C	IC(SYSTEM RESET)		
IC3		*	UPD75104GF-778	IC		
IC4			TC9163N	IC(BILATERAL SWITCH X16)		
IC5			TAB409S	IC(MOTOR CONTROL)		
IC6			TA7805S	IC(VOLTAGE REGULATOR/ +5V)		
IC6			UPC7805HF	IC(VOLTAGE REGULATOR/ +5V)		
IC11			TA7812S	IC(VOLTAGE REGULATOR/ +12V)		
IC11			UPC7812HF	IC(VOLTAGE REGULATOR/ +12V)		
Q1 ,2			2SC2878(B)	TRANSISTOR		
Q51			DTA124ES	DIGITAL TRANSISTOR		
Q51			UN4112	TRANSISTOR		
Q52			DTC124ES	DIGITAL TRANSISTOR		
Q52			UN4212	TRANSISTOR		
Q53			2SC1740S(Q,R)	TRANSISTOR		
Q53			2SC3311A(Q,R)	TRANSISTOR		
Q54			2SC2003(L,K)	TRANSISTOR		

L:Scandinavia K:USA P:Canada
 Y:PX(Far East, Hawaii) T:England E:Europe
 Y:AAFES(Europe) X:Australia M:Other Areas

⚠ indicates safety critical components.

× New Parts

Parts without Parts No. are not supplied.

Les articles non mentionnés dans le Parts No. ne sont pas fournis.

Teile ohne Parts No. werden nicht geliefert.

No. 7

Ref. No. 参照番号	Address 位置	New Parts 新	Parts No. 部品番号	Description 部品名 / 規格	Desti- nation 仕向	Re- marks 備考
Q55			2SA1309A(Q,R)	TRANSISTOR		
Q55			2SA933S(Q,R)	TRANSISTOR		
Q56			2SD1266(Q,P)	TRANSISTOR		
A1			W02-1046-05	ELECTRIC CIRCUIT MODULE		
PRE AMPLIFIER UNIT (X85-1010-010)						
C1 ,2			CF92FV1H392J	MF 3900PF J		
C3 ,4			CF92FV1H113J	MF 0.011UF J		
C5 ,6			CF92FV1H393J	MF 0.039UF J		
C7 ,8			C90-1332-05	NP-ELEC 10UF 25WV		
R7 ,8			RN14BK2C6811FTS	RN 6.81K F 1/6W		
R9 ,10			RN14BK2C8252FTS	RN 82.5K F 1/6W		
IC1			NJM4560D-N	IC		
Q5 -8			2SK170(BL)	FET		
Q5 -8			2SK170(V)	FET		

L:Scandinavia K:USA P:Canada
 Y:PX(Far East, Hawaii) T:England E:Europe
 Y:AAFES(Europe) X:Australia M:Other Areas

⚠ indicates safety critical components.

KA-4040R

PARTS LIST

SPECIFICATIONS

(For U.K. and Europe)

Continuous rated power output

(DIN) 1 kHz, at 8 Ω	70 W + 70 W
at 4 Ω	90 W + 90 W
(IEC/NF) From 63 Hz to 12,500 Hz, 0.7% T.H.D.	
at 8 Ω	70 W + 70 W
at 4 Ω	90 W + 90 W
Dynamic power	90 W (8 Ω)
	120 W (4 Ω)
	140 W (2 Ω)

Total harmonic distortion

0.06% (20 Hz ~ 20,000 Hz, 60 W, 8 Ω)
0.03% (1 kHz, 60 W, 8 Ω)

Intermodulation distortion 0.06% (60 W, 8 Ω) (70 Hz : 7 kHz = 4:1)

Frequency response

CD 5 Hz ~ 100 kHz, +0 dB, -3 dB

PHONO 'RIAA' response

..... 20 Hz ~ 20 kHz, +0.3 dB, -0.3 dB

Maximum input level

PHONO (MM) 120 mV, 0.06% T.H.D. at 1 kHz
PHONO (MC) 10 mV, 0.06% T.H.D. at 1 kHz

Signal to noise ratio

PHONO (MM) 87 dB (IHF '66)/80 dB (IHF '78)
PHONO (MC) 67 dB (IHF '66)/74 dB (IHF '78)
CD/TUNER/AUX/TAPE
..... 101 dB (IHF '66)/82 dB (IHF '78)
PHONO (MM) 58 dB (DIN, 50 mW output)
CD/TUNER/AUX/TAPE
..... 59 dB (DIN, 50 mW output)

Input sensitivity/impedance

PHONO (MM)	2.5 mV/47 kΩ
PHONO (MC)	0.2 mV/100 Ω
CD/TUNER/AUX/TAPE	200 mV/47 kΩ

Tone control

BASS	± 10 dB (at 100 Hz)
TREBLE	± 10 dB (at 10 kHz)

Loudness control

VOLUME at -30 dB level	
..... +6 dB (100Hz), +3 dB (10 kHz)	

Output level/impedance

TAPE REC	200 mV/1 kΩ
----------	-------------

General

Power consumption	200 W
AC outlet	
SWITCHED	200 W max.
Dimensions	W: 440 mm (17-5/16")
	H: 137 mm (5-3/8")
	D: 345 mm (13-9/16")
Weight (net)	8.7 kg (19.2 lb)

(For other countries)

Continuous rated power output

(IHF '66) From 20 Hz to 20,000 Hz 0.06% T.H.D.	
at 8 Ω	60 W + 60 W
(IEC/NF) From 63 Hz to 12,500 Hz, 0.7% T.H.D.	
at 8 Ω	70 W + 70 W
at 4 Ω	90 W + 90 W
Dynamic power	90 W (8 Ω)
	120 W (4 Ω)
	140 W (2 Ω)

Damping factor 60 (50 Hz)

Total harmonic distortion

0.06% (20 Hz ~ 20,000 Hz, 60 W, 8 Ω)
0.03% (1 kHz, 60 W, 8 Ω)

Intermodulation distortion 0.06% (60 W, 8 Ω) (70 Hz : 7 kHz = 4:1)

Frequency response

CD 5 Hz ~ 100 kHz, +0 dB, -3 dB

PHONO 'RIAA' response

..... 20 Hz ~ 20 kHz, +0.3 dB, -0.3 dB

Maximum input level

PHONO (MM) 120 mV, 0.06% T.H.D. at 1 kHz
PHONO (MC) 10 mV, 0.06% T.H.D. at 1 kHz

Signal to noise ratio

PHONO (MM) 87 dB (IHF '66)/80 dB (IHF '78)
PHONO (MC) 67 dB (IHF '66)/74 dB (IHF '78)
CD/TUNER/AUX/TAPE
..... 101 dB (IHF '66)/82 dB (IHF '78)

Input sensitivity/impedance

PHONO (MM)	2.5 mV/47 kΩ
PHONO (MC)	0.2 mV/100 Ω
CD/TUNER/AUX/TAPE	200 mV/47 kΩ

Tone control

BASS	± 10 dB (at 100 Hz)
TREBLE	± 10 dB (at 10 kHz)

Loudness control

VOLUME at -30 dB level	
..... +6 dB (100Hz), +3 dB (10 kHz)	

Output level/impedance

TAPE REC	200 mV/1 kΩ
----------	-------------

General

Power consumption	200 W
AC outlet	
SWITCHED	Total 200 W max.
Dimensions	W: 440 mm (17-5/16")
	H: 137 mm (5-3/8")
	D: 345 mm (13-9/16")
Weight (net)	8.7 kg (19.2 lb)

KA-4040R

SPECIFICATIONS

(For Canada)

Continuous rated power output (FTC)

60 watts per channel minimum RMS, both channels driven, at 8 Ω from 20 Hz to 20,000 Hz with no more than 0.05% total harmonic distortion.

Dynamic power	90 W (8 Ω)
	120 W (4 Ω)
	140 W (2 Ω)
Damping factor	80 (50 Hz)
Total harmonic distortion	0.06% (20 Hz - 20,000 Hz, 60 W, 8 Ω)
	0.03% (1 kHz, 60 W, 8 Ω)
Intermodulation distortion	0.08% (80 W, 8 Ω)
(70 Hz : 7 kHz = 4:1)	
Frequency response	
CD	5 Hz - 20 kHz, +0 dB, -3 dB
PHONO 'RIAA' response	20 Hz - 20 kHz, +0.3 dB, -0.3 dB
Maximum input level	
PHONO (MM)	120 mV, 0.06% T.H.D. at 1 kHz
PHONO (MC)	10 mV, 0.06% T.H.D. at 1 kHz
Signal to noise ratio	
PHONO (MM)	87 dB (IHF '66)/80 dB (IHF '78)
PHONO (MC)	87 dB (IHF '66)/74 dB (IHF '78)
CD/TUNER/AUX/TAPE	101 dB (IHF '66)/92 dB (IHF '78)
Input sensitivity/impedance	
PHONO (MM)	2.6 mV/47 k Ω
PHONO (MC)	0.2 mV/100 Ω
CD/TUNER/AUX/TAPE	200 mV/47 k Ω
Tone control	
BASS	\pm 10 dB (at 100 Hz)
TREBLE	\pm 10 dB (at 10 kHz)
Loudness control	
VOLUME at -30 dB level	+ 5 dB (100Hz), + 3 dB (10 kHz)
Output level/impedance	
TAPE REC	200 mV/1 k Ω

General

Power consumption	2.6 A
AC outlets	
SWITCHED	For Canada: 3: (Total 200 W, 1.6 A max.)
Dimensions	W: 440 mm (17-5/16") H: 137 mm (5-3/8") D: 345 mm (13-9/16")
Weight (net)	8.7 kg (19.2 lb)

Note:

©1994 Kenwood. A policy of continuous advancements in development. For this reason specifications may be changed without notice.

Note:

Component and circuitry are subject to modification to insure best operation under differing local conditions. This manual is based on the Europe (E) standard, and provides information on regional circuit modification through use of alternate schematic diagrams, and information on regional component variations through use of parts list.

KENWOOD CORPORATION

Osaka Shingyo Bldg., 7F, 2-chome Shibuya, Shibuya-ku, Tokyo 150, Japan

KENWOOD U.S.A. CORPORATION
2201 East Dominguez Street, Long Beach, CA 90810
370 Civic Drive, Mountlake Park, WA 98273, U.S.A.

KENWOOD ELECTRONICS CANADA, INC.
PO BOX 1075, 999 Ross Court, Vancouver, British Columbia, Canada V6T 4C2

TRIO-KENWOOD U.K. LIMITED
KENWOOD House, Dalgh Road, Watford, Herts., WD1 8EB United Kingdom

KENWOOD ELECTRONICS BENELUX, NV
Moulin de la Sablonerie, 1010-1000 Zaventem, Belgium

KENWOOD ELECTRONICS DEUTSCHELAND GMBH
Hardenberg-Str. 15, 8000 Muenchen 40, FRG Germany

TRIO-KENWOOD FRANCE S.A.

15 Boulevard Ney, 75018 Paris, France

KENWOOD LINEAR S.p.A.

20126, MILANO VIA ARBE 50, ITALY

KENWOOD ELECTRONICS AUSTRALIA PTY LTD. (Incorporated in Australia)

46 Woodcock Place, Lane Cove, NSW 2260, Australia

KENWOOD & LEE ELECTRONICS, LTD.

Wing Kee Building, 4th Floor, 24-27 Cross Street, Singapore