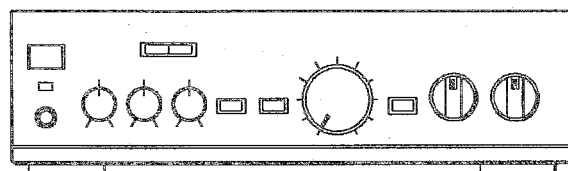

AIWA®**XA-006****SERVICE
MANUAL**

STEREO INTEGRATED AMPLIFIER

• TYPE. H.E.K,Z

SPECIFICATIONS

Common

Power requirements

XA - 006H
AC 120V/220V/240V
switchable, 50/60Hz
XA - 006E,Z
AC 220V, 50Hz
XA - 006K
AC 240V, 50Hz

Power consumption

XA - 006H 140W
XA - 006E,K,Z 380W

Power amplifier

Effective output power

75W + 75W
(4 ohms, T.H.D. 0.9%, 1kHz)
56W + 56W
(8 ohms, T.H.D. 0.9%, 1kHz)

Total harmonic distortion

0.018%
(20Hz - 20kHz, 40W, 8 ohms)

Output bandwidth

6Hz - 50kHz
(less than 0.05%)
[Both channels driven,
8 ohms]

Frequency response

5Hz - 80kHz
(+ 0.5/- 3dB)

Preamplifier

S/N ratio

IHF A curve short circuited
PHONO (MM) 89dB
(5mV input)
TUNER,CD,VCR/AUX,TAPE
/DAT 107dB

Input jacks

(Sensitivity/input impedance)
PHONO (MM) 2.5mV/47k
ohms
TUNER,CD,VCR/AUX,TAPE
/DAT 150mV/47k ohms

PHONO overload level

85mV (MM)
[1kHz, T.H.D. 0.01%]

Output jacks

(Level/output impedance)
TAPE/DAT 150mV/47k
ohms
Headphones 8 - 32 ohms
Speakers 4 - 16 ohms
(A + B : 8 - 16 ohms)

RIAA deviation

± 0.5dB (30Hz - 15kHz)

Maximum dimensions

430 (W) x 128 (H) x 332 (D)
mm

Weight

7.6kg

• Design and specifications are subject to change without notice.

AIWA Co., Ltd.**Tokyo Japan**

Printed in Japan

ELECTRICAL MAIN PARTS LIST

REF. NO.	PART NO.	DESCRIPTION	REF. NO.	PART NO.	DESCRIPTION
=== IC ===					
	87-001-383-010	IC, M5220P	J1-2	*87-009-394-010	JACK PIN 4P EARTH(PHONO)
	87-001-171-010	IC, NJM2068D	J1-3	*87-009-394-010	JACK PIN 4P EARTH(TUNER)
	87-027-897-019	IC, UPC1225H	J1-4	*87-009-394-010	JACK PIN 4P EARTH(TUNER)
	87-027-787-019	IC, UPC1237H	J2-1	*87-009-391-010	JACK PIN 4P(CD)
=== TRANSISTOR ===					
	80-AA1-650-010	TRANSISTOR, 2SA1264	J2-2	*87-009-391-010	JACK PIN 4P(CD)
	80-AA1-651-010	TRANSISTOR, 2SC3181	J2-3	*87-009-391-010	JACK PIN 4P(VCR/AUX)
	89-110-155-019	TRANSISTOR, 2SA1015GR	J2-4	*87-009-391-010	JACK PIN 4P(VCR/AUX)
	89-213-302-319	TRANSISTOR, 2SB1330	J3-1	*87-009-392-010	JACK PIN 6P(2 PLAY)
	89-322-405-019	TRANSISTOR, 2SC2240GR	J3-2	*87-009-392-010	JACK PIN 6P(2 PLAY)
	89-334-194-010	TRANSISTOR, 2SC3419Y	J3-3	*87-009-392-010	JACK PIN 6P(1 REC OUT)
	89-420-062-319	TRANSISTOR, 2SD2006	J3-4	*87-009-392-010	JACK PIN 6P(1 REC OUT)
	87-026-369-019	TRANSISTOR, RN1207	J3-5	*87-009-392-010	JACK PIN 6P(1 PLAY)
=== DIODE ===					
	87-001-559-019	DIODE 1SS131	J4-1	*87-009-392-010	JACK PIN 6P(LINE OUT)
	87-001-749-010	DIODE D5SB20	J4-2	*87-009-392-010	JACK PIN 6P(LINE OUT)
	87-020-123-019	DIODE DS446-AT	J4-3	*87-009-392-010	JACK PIN 6P(LINE IN)
	87-001-783-019	DIODE IN4002-T	J4-4	*87-009-392-010	JACK PIN 6P(LINE IN)
	87-027-449-019	DIODE, ZENER HZ15-3L	J4-5	*87-009-392-010	JACK PIN 6P(2 REC OUT)
=== MAIN CIRCUIT BOARD SECTION ===					
C11	*87-018-121-019	CAP, CERA-SOL SS 150P-50(Z MODEL ONLY)	J4-6	*87-009-392-010	JACK PIN 6P(2 REC OUT)
C12	*87-018-121-019	CAP, CERA-SOL SS 150P-50(Z MODEL ONLY)	J6-1	*87-033-211-010	TERMINAL, 8P(SPEAKERS A)(H, E MODELS)
C15	*87-018-121-019	CAP, CERA-SOL SS 150P-50(Z MODEL ONLY)	J6-2	*87-033-211-010	TERMINAL, 8P(SPEAKERS B)(H, E MODELS)
C16	*87-018-121-019	CAP, CERA-SOL SS 150P-50(Z MODEL ONLY)	J6-1	*87-033-210-010	TERMINAL, 8P(SPEAKERS A)(K, Z MODELS)
C17	*87-018-121-019	CAP, CERA-SOL SS 150P-50(Z MODEL ONLY)	J6-2	*87-033-210-010	TERMINAL, 8P(SPEAKERS B)(K, Z MODELS)
C18	*87-018-121-019	CAP, CERA-SOL SS 150P-50(Z MODEL ONLY)	L1	*87-005-158-010	COIL, 1UH
C19	*87-018-127-019	CAP, CERA-SOL SS 470P-50(Z MODEL ONLY)	L2	*87-005-158-010	COIL, 1UH
C20	*87-018-127-019	CAP, CERA-SOL SS 470P-50(Z MODEL ONLY)	L3	*87-005-154-019	COIL, 220UH(Z MODEL ONLY)
C21	*87-018-134-019	CAP, CERA-SOL SS 0.01-16	L4	*87-005-154-019	COIL, 220UH(Z MODEL ONLY)
C31	*87-010-404-019	CAP, ELECT 4.7-50 SME	L5	*87-005-154-019	COIL, 220UH(Z MODEL ONLY)
C32	*87-010-404-019	CAP, ELECT 4.7-50 SME	L6	*87-005-154-019	COIL, 220UH(Z MODEL ONLY)
C33	*87-018-125-019	CAP, CERA-SOL SS 330P-50	R83	*87-025-434-010	RES, CEMENT 0.22-5W
C34	*87-018-125-019	CAP, CERA-SOL SS 330P-50	R84	*87-025-434-010	RES, CEMENT 0.22-5W
C35	*87-010-370-019	CAP, ELECT 330-6.3 SME	R85	*87-025-434-010	RES, CEMENT 0.22-5W
C36	*87-010-370-019	CAP, ELECT 330-6.3 SME	R86	*87-025-434-010	RES, CEMENT 0.22-5W
C43	*87-010-260-019	CAP, ELECT 47-25 SME	R95	*87-025-487-019	RES, MF 10-1W
C44	*87-010-260-019	CAP, ELECT 47-25 SME	R96	*87-025-487-019	RES, MF 10-1W
C45	*87-010-404-019	CAP, ELECT 4.7-50 SME	△ R99	87-029-366-019	RES, FUSE 4.7-1/2W F
C46	*87-010-404-019	CAP, ELECT 4.7-50 SME	△ R100	87-029-366-019	RES, FUSE 4.7-1/2W F
C51	*87-010-405-019	CAP, ELECT 10-50 SME	△ R101	87-029-124-019	RES, FUSE 2.2-1/4W
C52	*87-010-405-019	CAP, ELECT 10-50 SME	R113	*87-025-486-019	RES, F 820-1W
C53	*87-018-131-019	CAP, CERA-SOL SS 1000P-50	R121	*87-025-476-019	RES, NF 33-1/4WJ
C54	*87-018-131-019	CAP, CERA-SOL SS 1000P-50	R122	*87-025-476-019	RES, NF 33-1/4WJ
C55	*87-010-247-019	CAP, ELECT 100-50 SME	R127	*87-025-471-019	RES, NF 4.7-1/4WJ
C56	*87-010-247-019	CAP, ELECT 100-50 SME	R128	*87-025-471-019	RES, NF 4.7-1/4WJ
C69	*87-018-119-019	CAP, CERA-SOL SS 100P-50(Z MODEL ONLY)	RY1	87-045-316-010	RELAY, VB-24SMBU-SP
C70	*87-010-401-019	CAP, ELECT 1-50 SME	S1	80-AA1-633-010	ROTARY SW(FUNCTION)
C71	*87-018-131-019	CAP, CERA-SOL SS 1000P-50	S2	80-AA1-633-010	ROTARY SW(REC OUT)
C72	*87-010-762-019	CAP, ELECT 220-10 BP	S6	80-AA1-634-010	PUSH SW(SPEAKERS A)
C74	*87-010-404-019	CAP, ELECT 4.7-50 SME	S7	80-AA1-634-010	PUSH SW(SPEAKERS B)
C75	*87-010-260-019	CAP, ELECT 47-25 SME	SFR1	*87-024-165-019	SFR, 220
C81	*87-010-876-010	CAP, ELECT 6800-50 SME	SFR2	*87-024-165-019	SFR, 220
C82	*87-010-876-010	CAP, ELECT 6800-50 SME	=== FRONT CIRCUIT BOARD SECTION ===		
C83	*87-010-260-019	CAP, ELECT 47-25 SME	C121	*87-018-126-019	CAP, CERA-SOL SS 390P-50
C84	*87-010-260-019	CAP, ELECT 47-25 SME	C122	*87-018-126-019	CAP, CERA-SOL SS 390P-50
C85	*87-010-408-019	CAP, ELECT 47-50 SME	C125	*87-010-401-019	CAP, ELECT 1-50 SME
C86	*87-010-408-019	CAP, ELECT 47-50 SME	C126	*87-010-401-019	CAP, ELECT 1-50 SME
C109	*87-018-134-019	CAP, CERA-SOL SS 0.01-16(Z MODEL ONLY)	C127	*87-018-121-019	CAP, CERA-SOL SS 150P-50
C110	*87-018-134-019	CAP, CERA-SOL SS 0.01-16(Z MODEL ONLY)	C128	*87-018-121-019	CAP, CERA-SOL SS 150P-50
J1-1	*87-009-394-010	JACK PIN 4P EARTH(PHONO)	C129	*87-010-382-019	CAP, ELECT 22-25 SME
			C130	*87-010-382-019	CAP, ELECT 22-25 SME
			C137	*87-018-123-019	CAP, CERA-SOL SS 220P-50
			C138	*87-018-123-019	CAP, CERA-SOL SS 220P-50
			C141	*87-010-382-019	CAP, ELECT 22-25 SME
			C142	*87-010-382-019	CAP, ELECT 22-25 SME

REF.NO.	PART NO.	DESCRIPTION
C143	*87-010-260-019	CAP,ELECT 47-25 SME
C144	*87-010-260-019	CAP,ELECT 47-25 SME
S3	80-AA1-635-010	PUSH SW(LOUDNESS)
S4	80-AA1-636-010	PUSH SW(DIRECT)
S5	80-AA1-635-010	PUSH SW(MUTING)
VR1	80-AA1-630-010	VOLUME,100KB(VOLUME)
VR2	80-AA1-631-010	VOLUME,100K(BALANCE)
VR3	80-AA1-632-010	VOLUME,50KC(BASS)
VR4	80-AA1-632-010	VOLUME,50KC(TREBLE)

=== POWER-1 CIRCUIT BOARD SECTION ===

△	*87-033-213-019	CLAMP FUSE(H MODEL)
△	F3 87-035-190-019	FUSE,T2A(H MODEL)
△	F4 87-035-190-019	FUSE,T2A(H MODEL)

=== POWER-2 CIRCUIT BOARD SECTION ===

△	*87-033-213-019	CLAMP FUSE
△	F1 87-035-194-019	FUSE,6.3AT(H MODEL)
△	F1 87-035-370-010	FUSE,6.3A-250V(EXCEPT H MODEL)
△	F2 87-035-194-019	FUSE,6.3AT(H MODEL)
△	F2 87-035-370-010	FUSE,6.3A-250V(EXCEPT H MODEL)

=== POWER SW CIRCUIT BOARD SECTION ===

△	C111 *87-019-112-019	SPARK KILLER 0.01E
△	J5 87-009-043-010	JACK,6,3(PHONES)
△	S8 87-036-210-010	PUSH SW(POWER)

=== LED CIRCUIT BOARD SECTION ===

LED1	87-001-779-019	LED,SLH-56VC 70F165(POWER)
------	----------------	----------------------------

=== AC VOLTAGE SW CIRCUIT BOARD SECTION(H MODEL) ===

△	S9 87-036-067-010	SLIDE SW(AC VOLTAGE)
---	-------------------	----------------------

=== MISCELLANEOUS ===

△	*87-034-749-019	AC CORD(H)(HJ MODEL ONLY)
△	*87-085-184-010	BUSHING,AC CORD D(HJ MODEL ONLY)
△	*87-085-185-010	BUSHING,AC CORD E(H,E,K,Z MODELS)
△	*82-187-797-010	AC CORD(E)(H MODEL ONLY)
△	*87-034-592-010	AC CORD(BS)(K MODEL ONLY)
△	*87-034-781-010	AC CORD ASSY(E)(E,Z MODELS)
△	PT1 80-AA1-606-019	POWER TRANSFORMER H(H,HJ MODELS)
△	PT1 80-AA1-608-010	POWER TRANSFORMER E(E,Z MODELS)
△	PT1 80-AA1-609-010	POWER TRANSFORMER K(K MODEL)

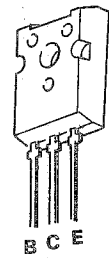

2SC3419

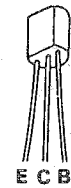

2SA1015
2SC2240
RN1207

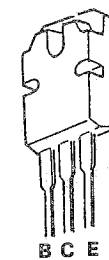

2SA1264
2SC3181

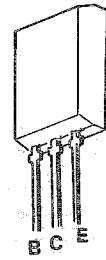

2SB1330
2SD2006

IC BLOCK DIAGRAM

IC,UPC1225H

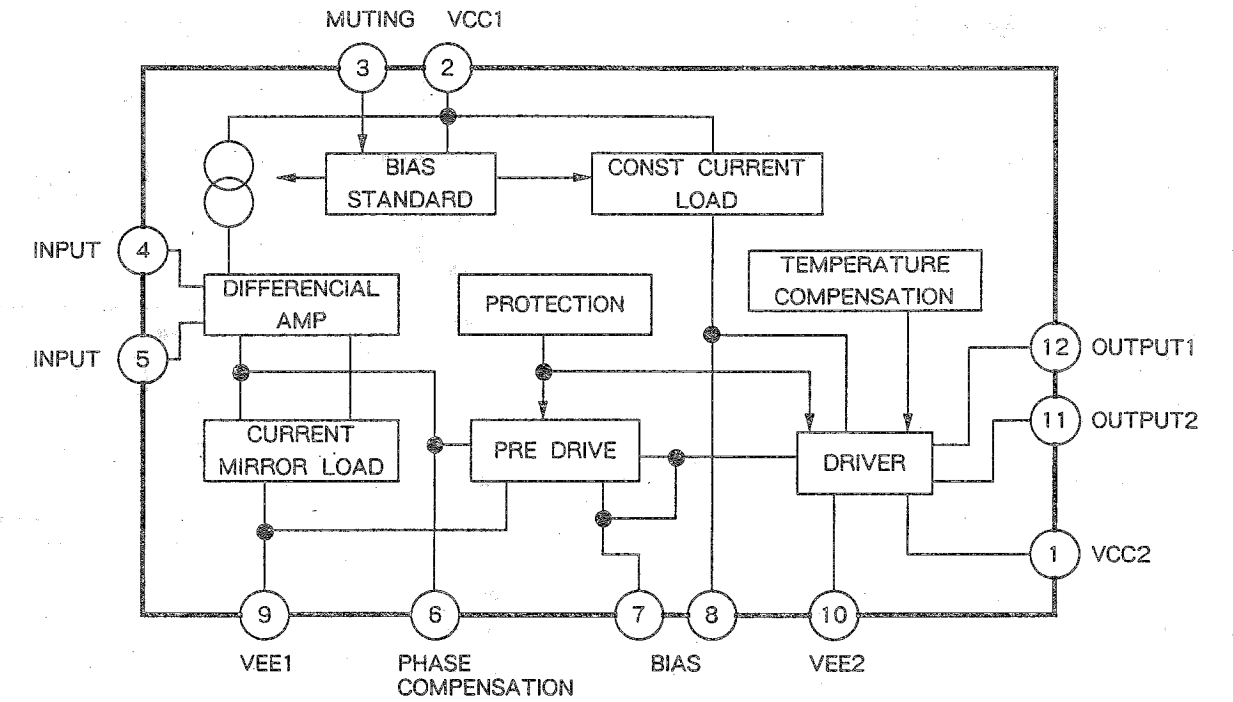

IC,UPC1237H

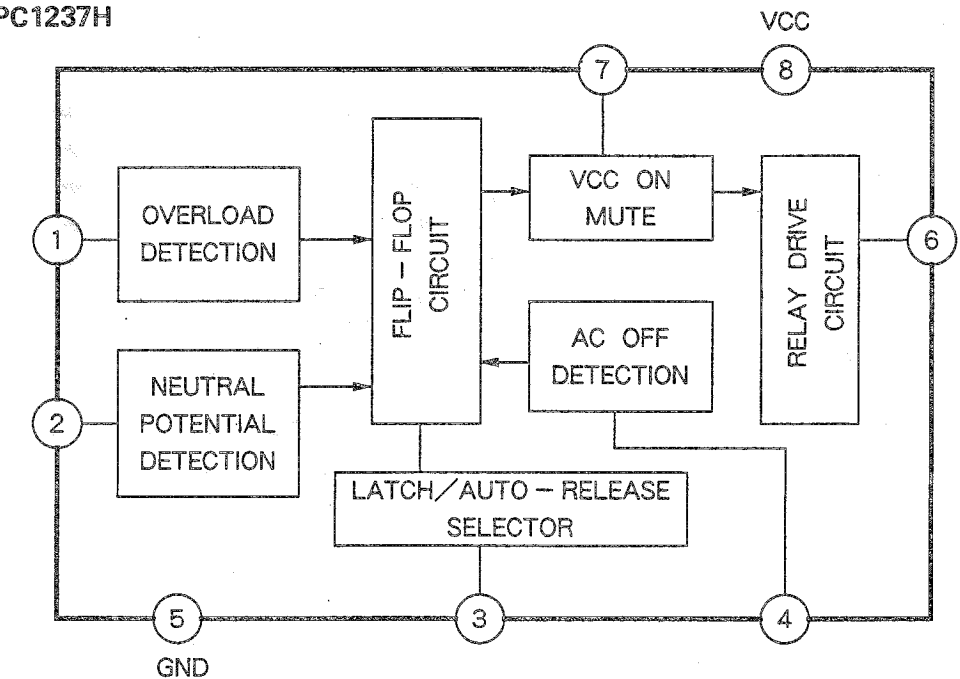

IC2 UPC1237H PIN⑦ VOLTAGE WAVE FORM

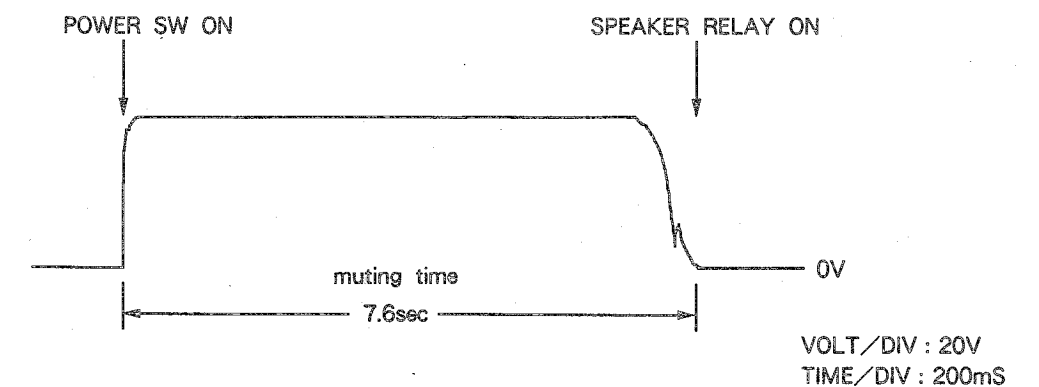

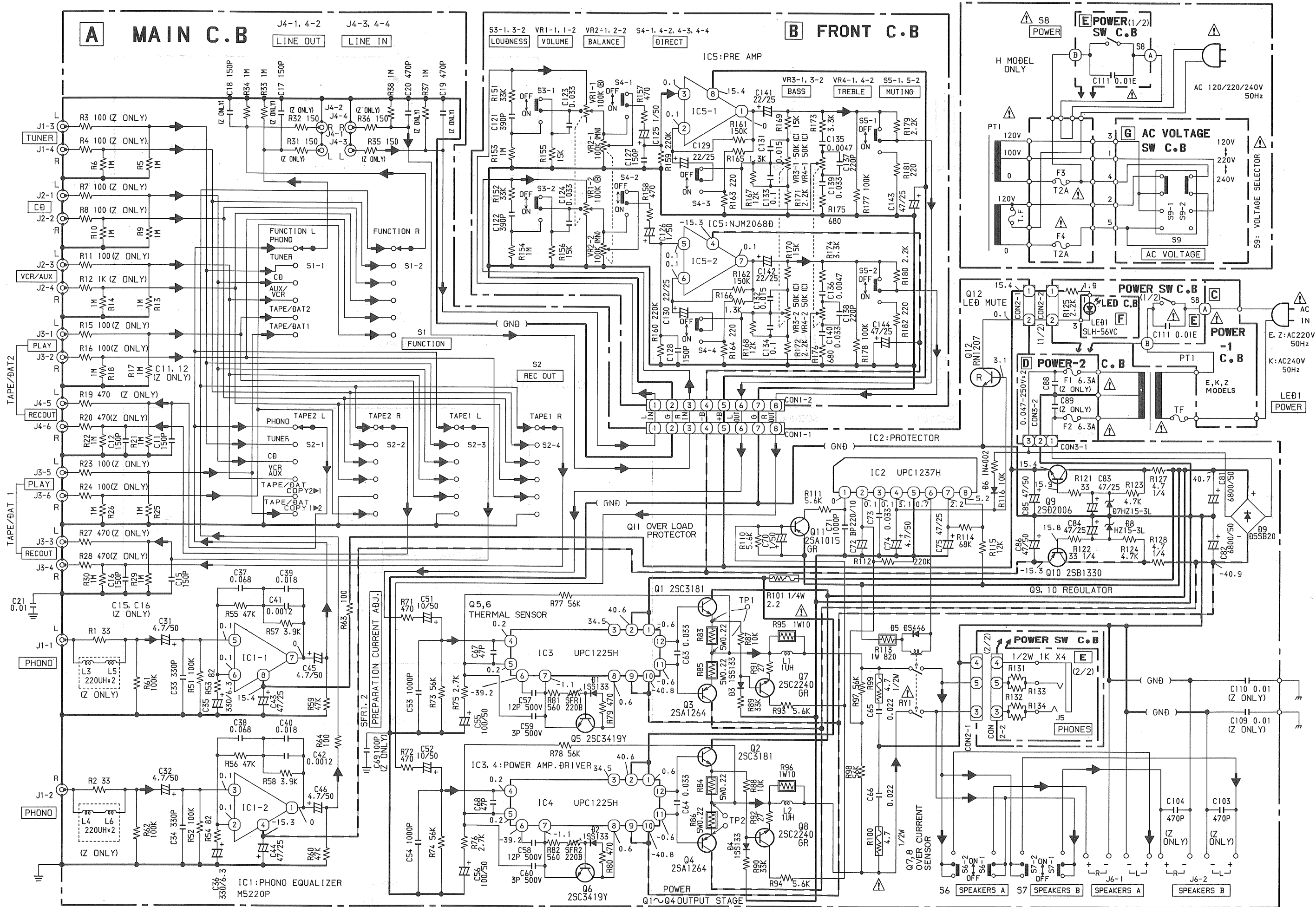

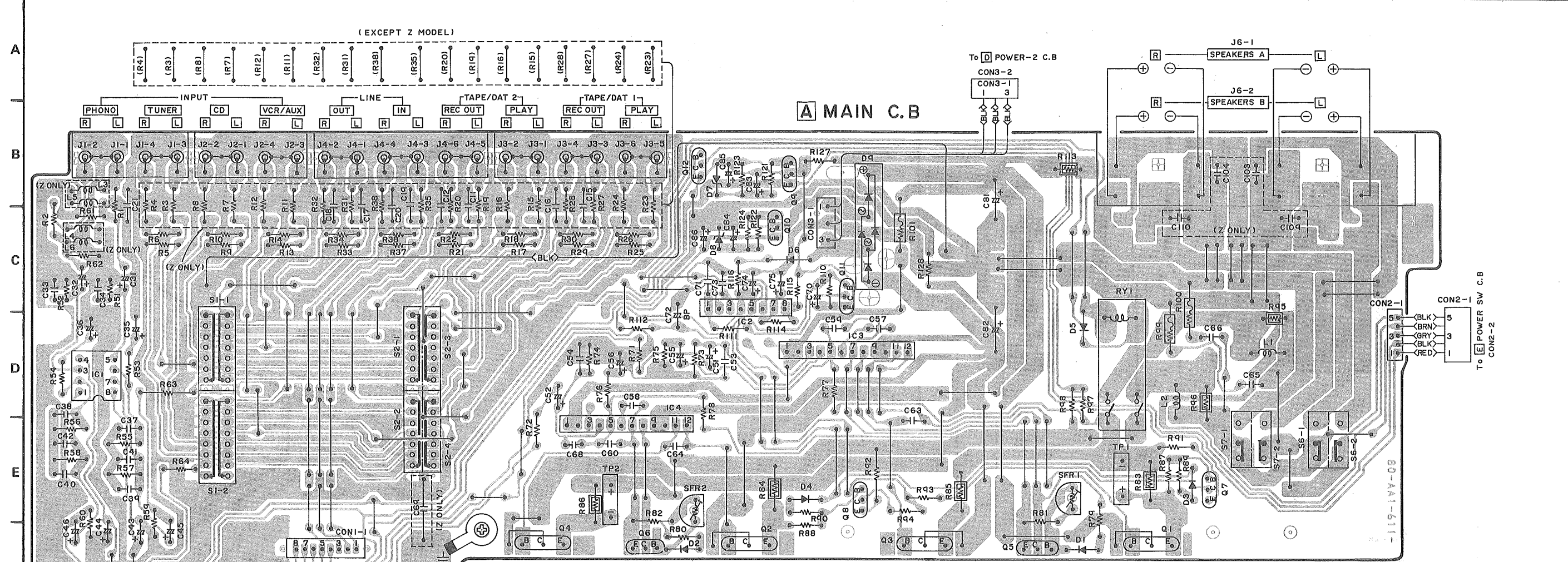

PREPARATION CURRENT ADJUSTMENT
 Method : • Connect a DC voltmeter across test points TP1, 2, adjust SFR1, 2 so that the voltage becomes $3.5 \pm 0.2mV$.
 Settings : • VOLUME : MIN
 • Test point : TP1 (Lch) TP2 (Rch)
 • Adjustment location : SFR1 (Lch) SFR2 (Rch)

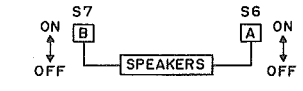

GRAPHIC SYMBOLS PRINTED CIRCUIT BOARD OF ELECT. CAP. ARE DESIGNED AS NEGATIVE POLE.
 (プリント基板内のケミコンの極性表示は⊖表示です。)

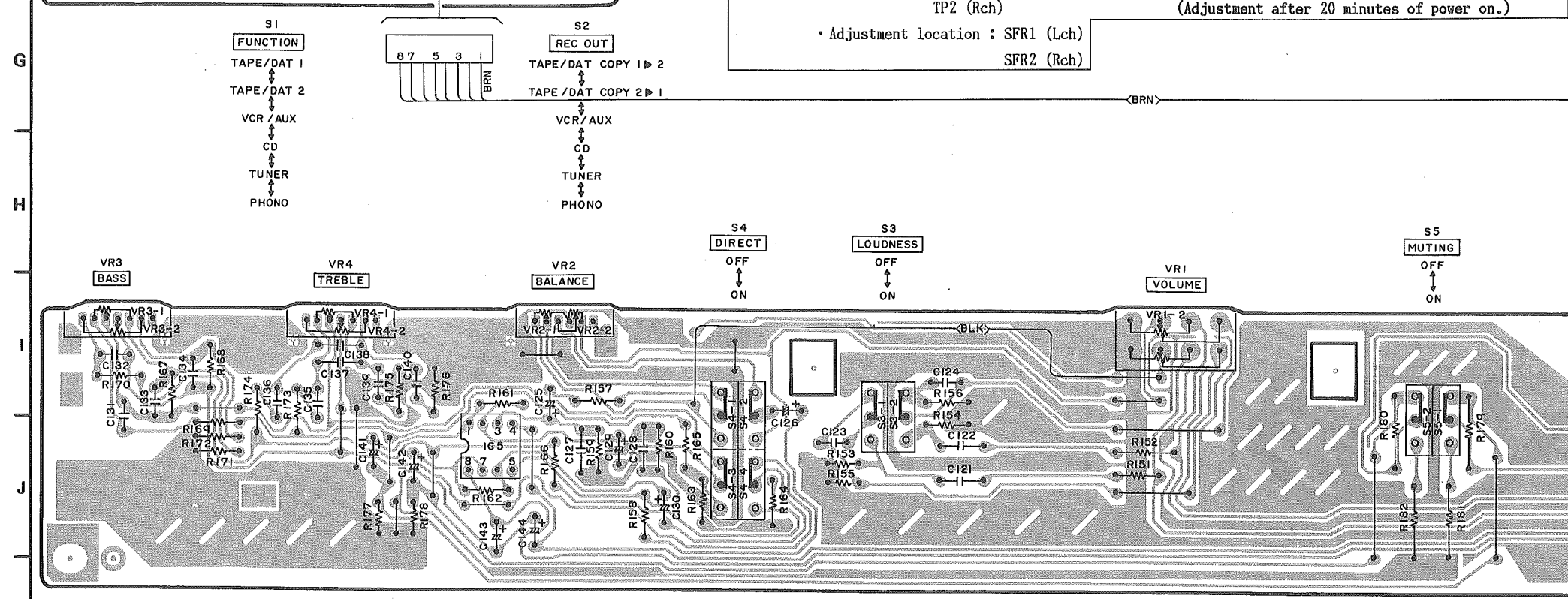

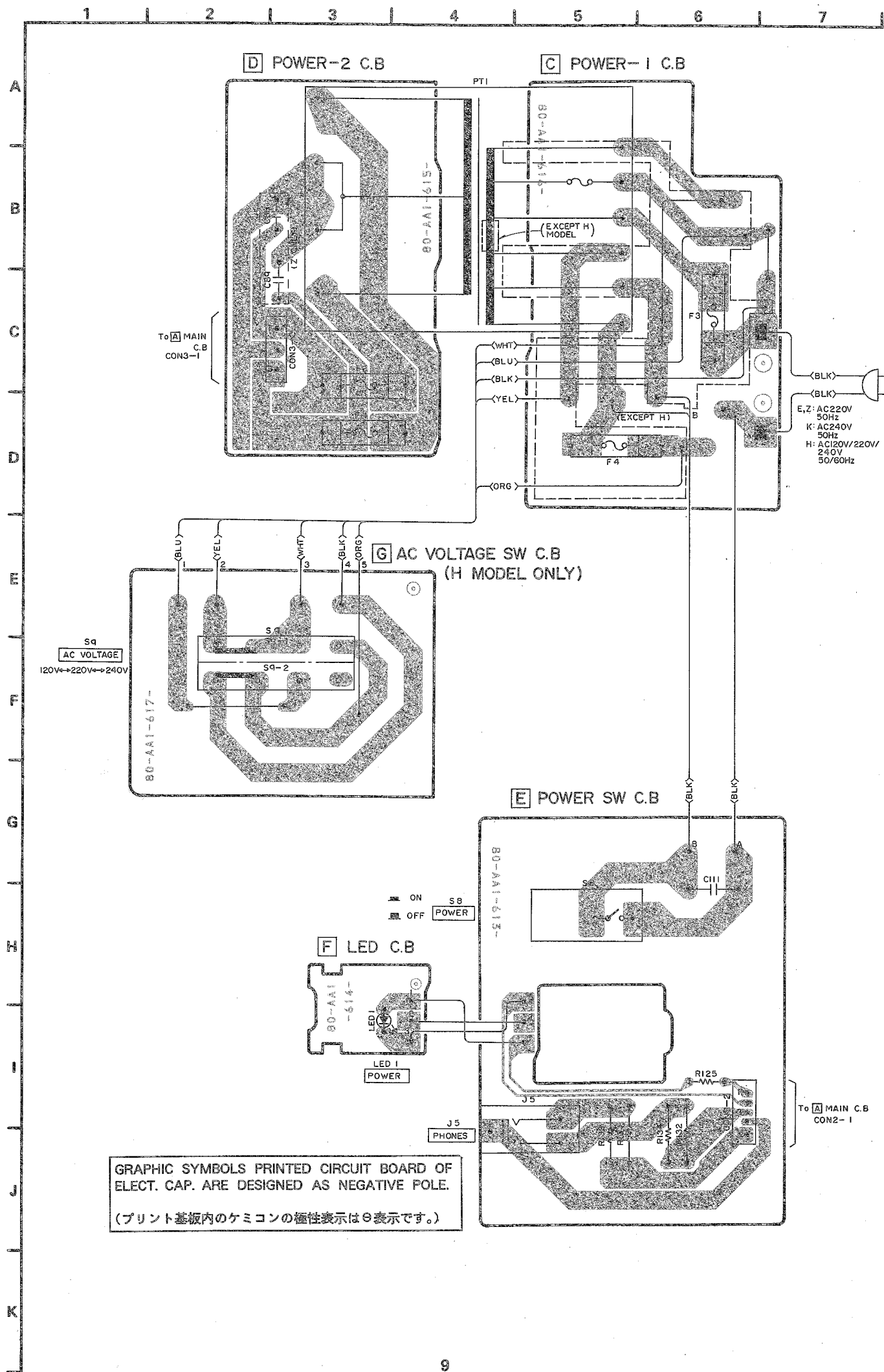

REF. NO.	PART NO.	DESCRIPTION
A	87-067-579-010	BVT ₂ +3-8 W/O SLOT
B	87-067-689-010	BVTI+3-8
C	87-591-094-410	QIT+3-6
D	87-743-095-410	UT ₂ +3-8(B)
E	87-743-096-410	UT ₂ +3-10(B)
F	87-067-540-019	SCREW CASE

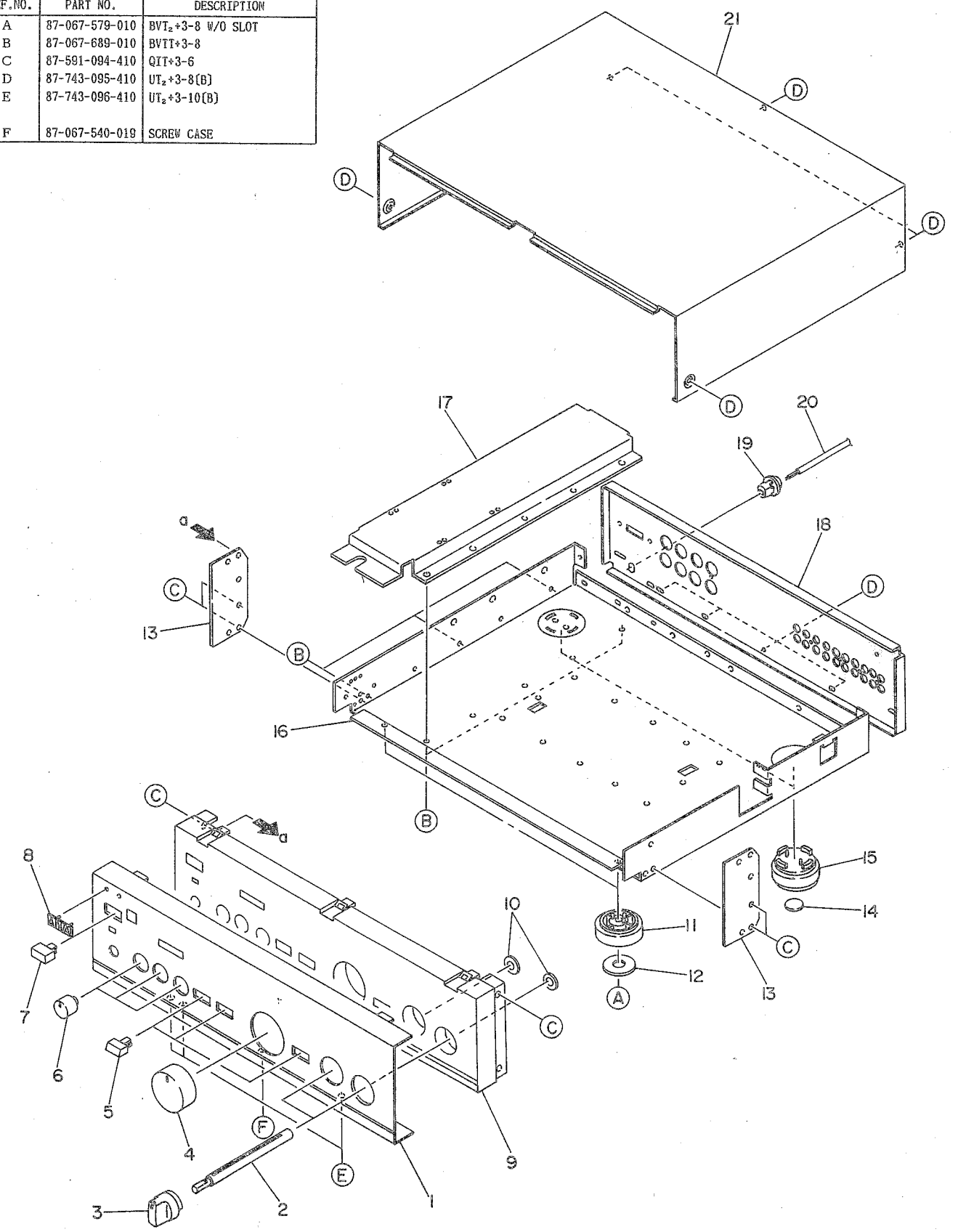

MECHANICAL PARTS LIST

PART NO. CHANGED TO	REF. NO.	PART NO.	DESCRIPTION	COMMON MODEL	Q. TY
	1-1	*80-AA1-002-010	PANEL,FR	*	1
	1-2	*80-AA1-205-010	ROD,SEL	*	2
	1-3	*80-AA1-007-019	KNOB,SEL	*	2
	1-4	*80-AA1-005-010	KNOB,VOLUME	*	1
	1-5	*80-AA1-008-019	BUTTON,MUTE	*	3
	1-6	*80-AA1-006-019	KNOB,BALANCE	*	3
	1-7	*84-721-023-010	BUTTON,POWER		1
	1-8	*84-764-009-119	BADGE,AIWA		1
	1-9	*80-AA1-001-010	CABINET,FR	*	1
	1-10	*81-663-213-019	CLOTH,DIA 18-8.7		2
	1-11	*84-738-022-010	FOOT		2
	1-12	*84-731-027-010	FELT,FOOT		2
	1-13	---	HOLDER,SIDE		2
	1-14	*80-DS3-206-019	G CUSHION,DIA 15-1		2
	1-15	80-DS3-014-119	FOOT,REAR ST		2
	1-16	---	CHASSIS,MAIN		1
	1-17	---	HOLDER,PT		1
	1-18	*80-AA1-004-019	PANEL,REAR(H)	*	1
	1-18	*80-AA1-012-019	PANEL,REAR(HJ)	*	1
	1-18	*80-AA1-009-019	PANEL,REAR(E)	*	1
	1-18	*80-AA1-010-019	PANEL,REAR(K)	*	1
	1-18	*80-AA1-011-119	PANEL,REAR(Z)	*	1
	1-19	87-085-184-010	BUSHING,AC CORD (HJ)		1
	1-19	87-085-185-010	BUSHING,AC CORD (H,E,K,Z)		1
	1-20	*82-187-797-019	AC CORD (H)		1
	1-20	*87-034-749-019	AC CORD (HJ)		1
	1-20	*87-034-781-018	AC CORD (E,Z)		1
	1-20	*87-034-592-018	AC CORD (K)		1
	1-21	*80-AA1-004-019	CABINET,STEEL	*	1

EXPLODED VIEW - 2

REF. NO.	PART NO.	DESCRIPTION
A	87-743-095-410	UT ₂ +3-8 W/O SLOT(B)
B	87-661-096-410	VFT ₁ +3-10
C	87-067-579-010	BVT ₂ +3-8 W/O SLOT
D	87-067-703-010	BVT ₂ +3-10 W/O SLOT
E	87-067-689-010	BVTT+3-8
F	87-067-585-010	BVTT+4-6

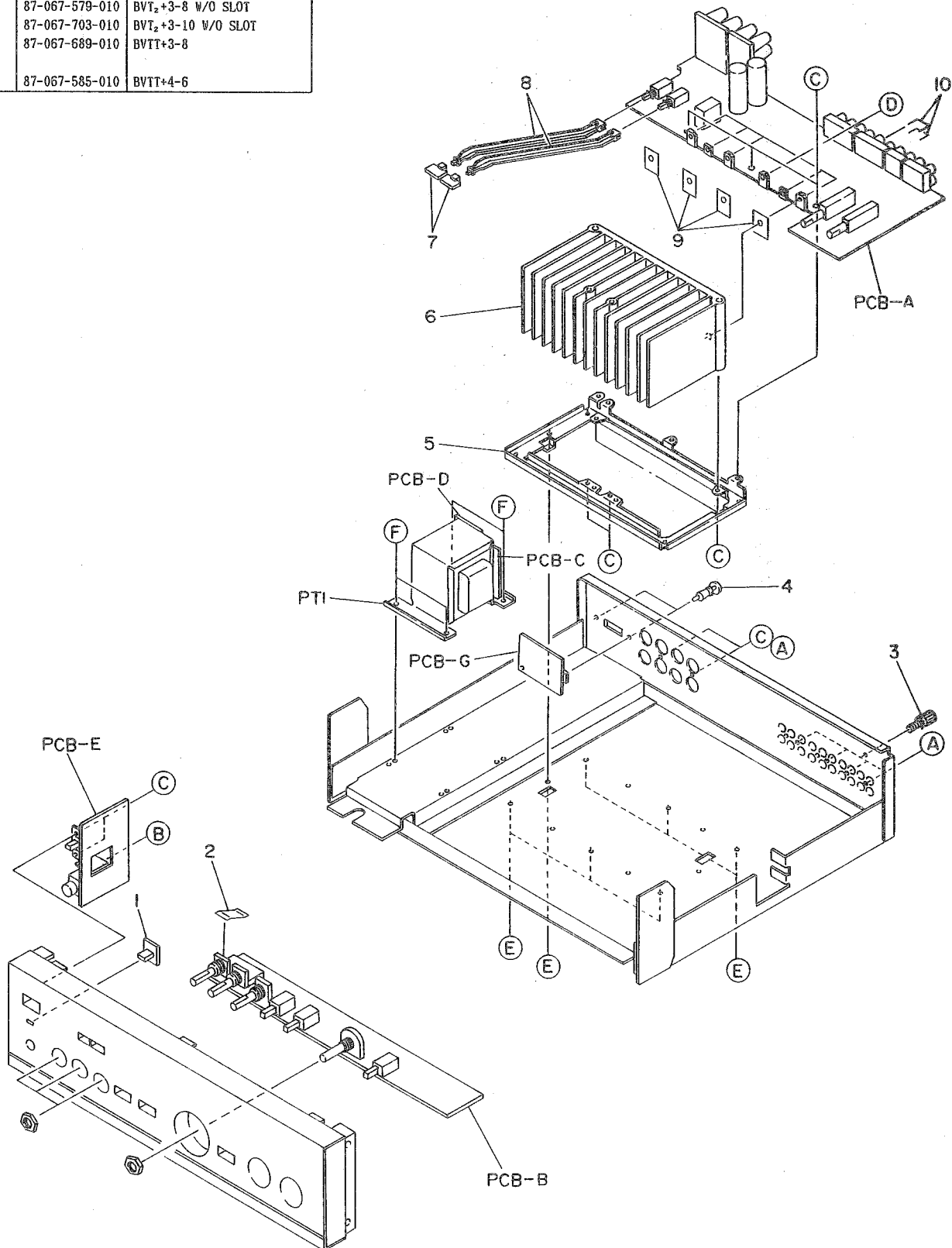

PART NO. CHANGED TO	REF. NO.	PART NO.	DESCRIPTION	COMMON MODEL	Q, TY
	2-1	*89-AA1-022-019	GUIDE, LIGHT MUTE		1
	2-2	80-AA1-618-010	SHEET, SHIELD 20-17-0.08	*	1
	2-3	---	TERMINAL, EARTH		1
	2-4	*87-084-063-019	RIVET, NYLON 3-5.5(H)		2
	2-5	---	HOLDER, HEAT-SINK		1
	2-6	---	HEAT-SINK, MAIN		1
	2-7	*80-MK4-024-019	BUTTON, TAPE		2
	2-8	*80-AA1-204-019	ROD, SPEAKER	*	2
	2-9	89-AA1-602-010	SHEET, T03PL MICA		4
	2-10	*87-009-389-010	JACK PIN SHORT-14		2

■ ACCESSORIES/PACKAGE LIST

PART NO. CHANGED TO	REF. NO.	PART NO.	DESCRIPTION	COMMON MODEL	Q, TY
	1	*80-AA1-901-010	INSTRUCTION BOOKLET, H (H)	※	1
	2	*80-AA1-902-010	INSTRUCTION BOOKLET, EKZ (E,K,Z)	※	1
	3	*87-042-062-010	PLUG ADAPTOR S-16115 (H)		1