

Model Name: MP1

Product Name: Mini PCI-E to PCI-E Adapter

Reference Schematic Rev. 1.0a

Schematic update note:

First released..2008/Jul/25th V0.9 Engineering sample

2nd released....2009/Feb/06th V1.0

3rd released....2009/Feb/10th V1.0a change R5, R6, R8 resistors

PCI-E Signals: Differential Pairs 100 ohm

- [1] Impedance control required for CLK+ CLK- PETXP PETXN PERXP PERXN : 100ohm
- [2] Impedance control required for DP DN : 90ohm

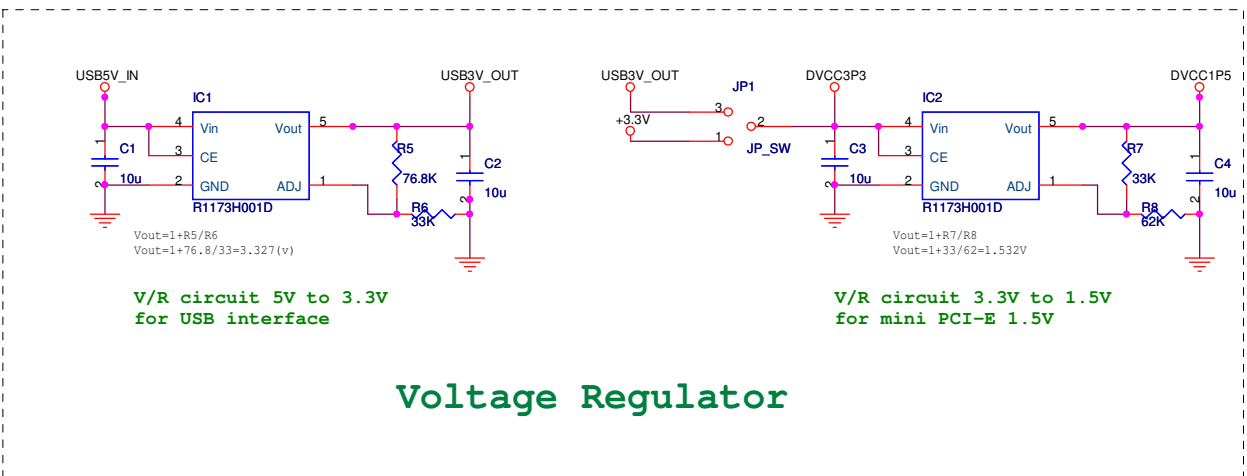
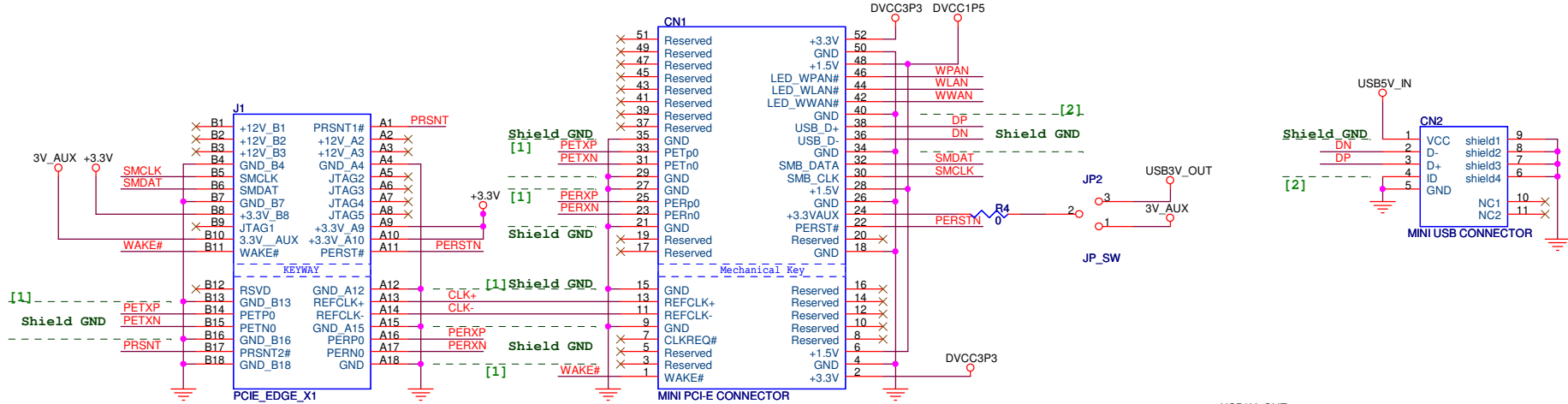

Voltage Regulator

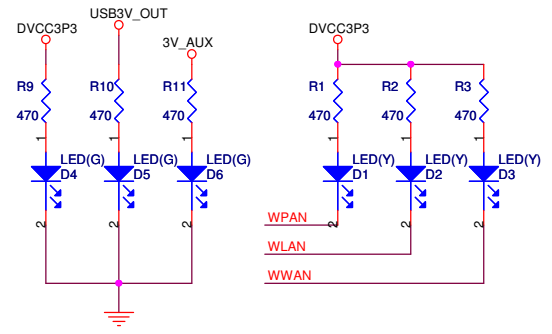

	Default 1-2	Select 2-3
JP1 3.3V	By PCI-E	By USB
JP2 AUX	By PCI-E	By USB