

SERVICE MANUAL

FE-1 CHASSIS

MODEL	COMMANDER	DEST	CHASSIS NO.	MODEL	COMMANDER	DEST	CHASSIS NO.
KV-25M2A	RM-883	Italian	SCC-Q06G-A	KV-25T2E	RM-883	Spanish	SCC-Q05H-A
KV-25T2A	RM-883	Italian	SCC-Q06H-A	KV-25M2K	RM-883	OIRT	SCC-Q03J-A
KV-25T2B	RM-883	French	SCC-Q02G-A	KV-25T2K	RM-883	OIRT	SCC-Q03K-A
KV-25M2D	RM-883	AEP	SCC-Q04G-A	KV-25T2R	RM-883	OIRT	SCC-Q03L-A
KV-25T2D	RM-883	AEP	SCC-Q04H-A	KV-25T2L	RM-883	Irish	SCC-Q07C-A
KV-25M2E	RM-883	Spanish	SCC-Q05G-A	KV-25T2U	RM-883	UK	SCC-Q01E-A

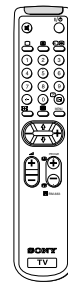

TRINITRON® COLOR TV
SONY®

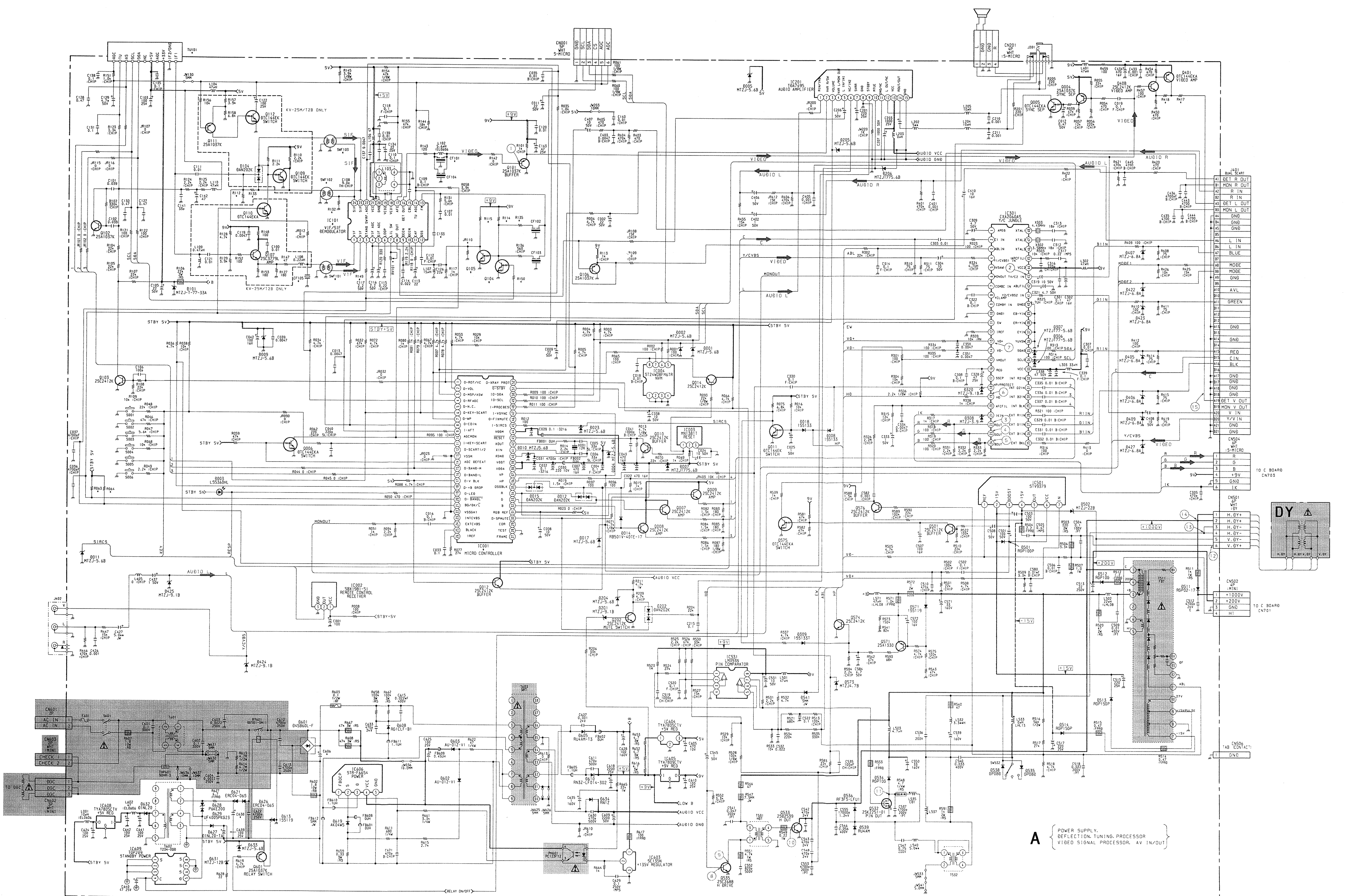

WAVEFORMS A BOARD

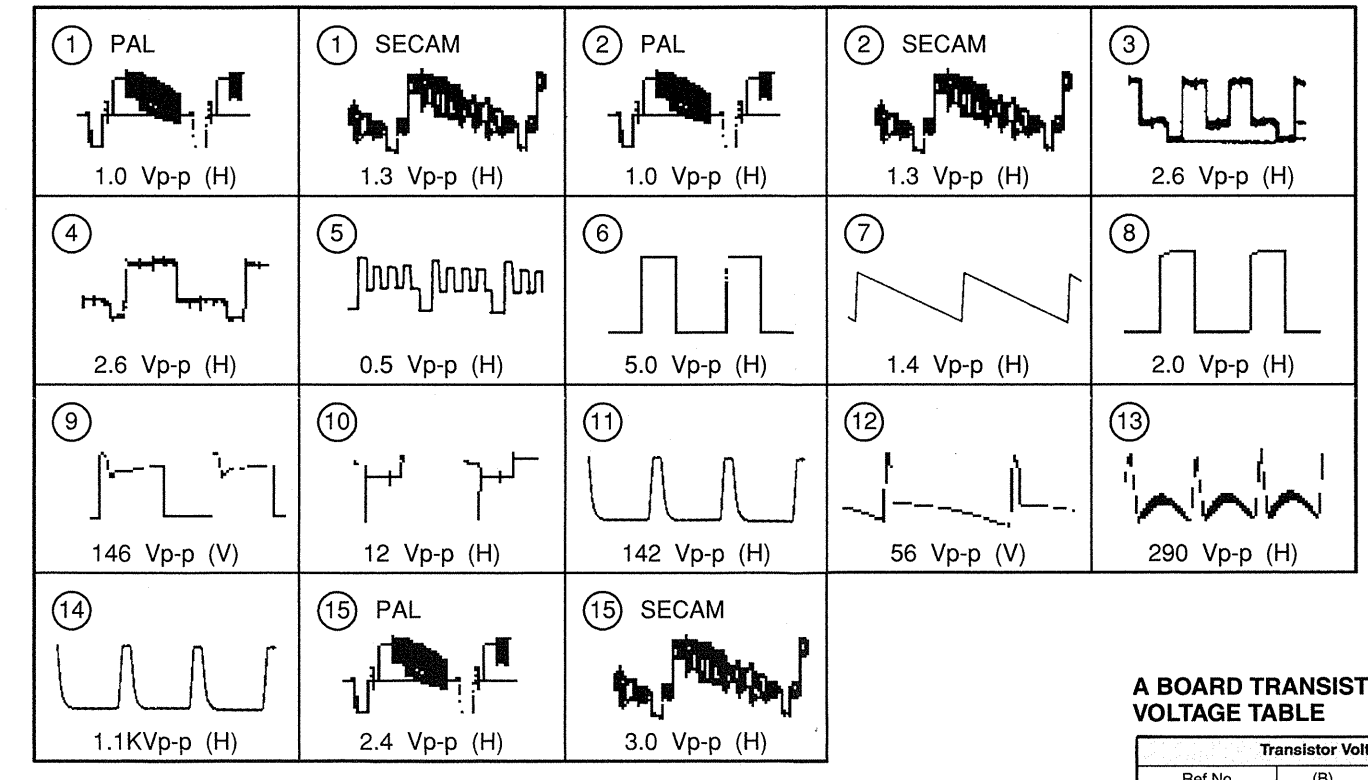

A BOARD TRANSISTOR VOLTAGE TABLE

Ref No	Transistor Voltage Table		
	(B) Base	(C) Collector	(E) Emitter
Q004	4.7	0.7	4.9
Q005	0.3	4.8	-
Q006	-	2.0	-
Q007	-	4.9	-
Q008	-	4.9	-
Q009	-	4.9	-
Q010	0.6	-	-
Q011	0.5	-	-
Q012	-	4.8	-
Q101	2.0	-	2.6
Q109	-	4.7	-
Q110	4.3	-	-
Q111	2.3	2.9	2.9
Q112	2.9	-	-
Q202	0.6	-	-
Q401	8.0	3.4	8.6
Q408	2.6	8.0	2.0
Q532	7.3	3.1	-
Q535	-0.2	-152.0	-
Q571	-0.7	92.0	-
Q574	-	2.0	-
Q576	3.4	6.7	2.8
Q601	4.0	3.6	4.8

A BOARD *MARK-2

IC001	SAA5491PS/M1A/019	KV-25M2A/25M2D/25M2E/25M2K
IC001	SAA5498PS/M1A/041	KV-25T2A/25T2B/25T2E/25T2K/25T2L/25T2U
IC001	SAA5498PS/M1A/043	KV-25T2D
IC001	SAA5498PS/M1A/042	KV-25T2R

A BOARD * MARK

Ref	25M2A/25T2A	25T2B	25M2D/25T2D	25M2E/25T2E	25M2K/25T2K	25T2L	25T2R	25T2U
C133	-	1Mf	-	-	-	-	-	-
C606	330MF 400V	330MF 400V	330MF 400V	330MF 400V	330MF 400V	330MF 400V	330MF 450V	330MF 400V
C638	10MF 400V	10MF 400V	10MF 400V	10MF 400V	10MF 400V	10MF 400V	10MF 450V	10MF 400V
CF101	1-404-801-11	1-409-430-11	1-404-801-11	1-404-801-11	1-404-801-11	1-409-429-11	1-404-801-11	1-409-429-11
CF102	-	-	-	-	1-567-101-11	-	1-567-101-11	-
CF103	1-760-106-11	1-760-106-11	1-760-106-11	1-760-106-11	1-760-106-11	1-567-100-11	1-760-106-11	1-567-100-00
CF104	-	-	-	-	1-409-327-00	-	1-409-327-00	-
IC001	Refer to 'A Board *Mark -2' Table							
IC101	TDA9817/V1	TDA9818/V1	TDA9817/V1	TDA9817/V1	TDA9817/V1	TDA9817/V1	TDA9817/V1	TDA9817/V1
JR110	0	0	0	0	0	0	0	0
Q104	-	-	-	-	DTC144EKA	-	DTC144EKA	-
Q105	-	-	-	-	DTC144EKA	-	DTC144EKA	-
R063	-	4.7K	-	-	-	-	-	-
R064	-	4.7K	-	-	-	-	-	-
R112	-	2.2K	-	-	-	-	-	-
R114	-	-	-	-	2.2K	-	2.2K	-
R115	-	-	-	-	2.2K	-	2.2K	-
R132	0	-	0	0	0	0	0	0
R133	0	-	0	0	0	0	0	0
R135	-	-	-	-	560	-	560	-
R150	-	-	-	-	100	-	100	-
R417	75	75	75	75	68	75	68	68
R418	470	470	470	470	470	560	470	560
RF101	-	22K	-	-	-	-	-	-
SWF101	1-579-120-11	1-579-273-11	1-579-120-11	1-579-120-11	1-579-414-11	1-760-711-11	1-579-414-11	1-760-711-11
SWF102	-	1-767-873-11	-	-	-	-	-	-
SWF103	-	1-767-083-11	-	-	-	-	-	-
TU101	VSS BT-AC401	TEL4-002B	VSS BT-AC401	VSS BT-AC401	VSS BT-AC401	VSS BT-AC401	VSS BT-AC401	VSS BT-AC401

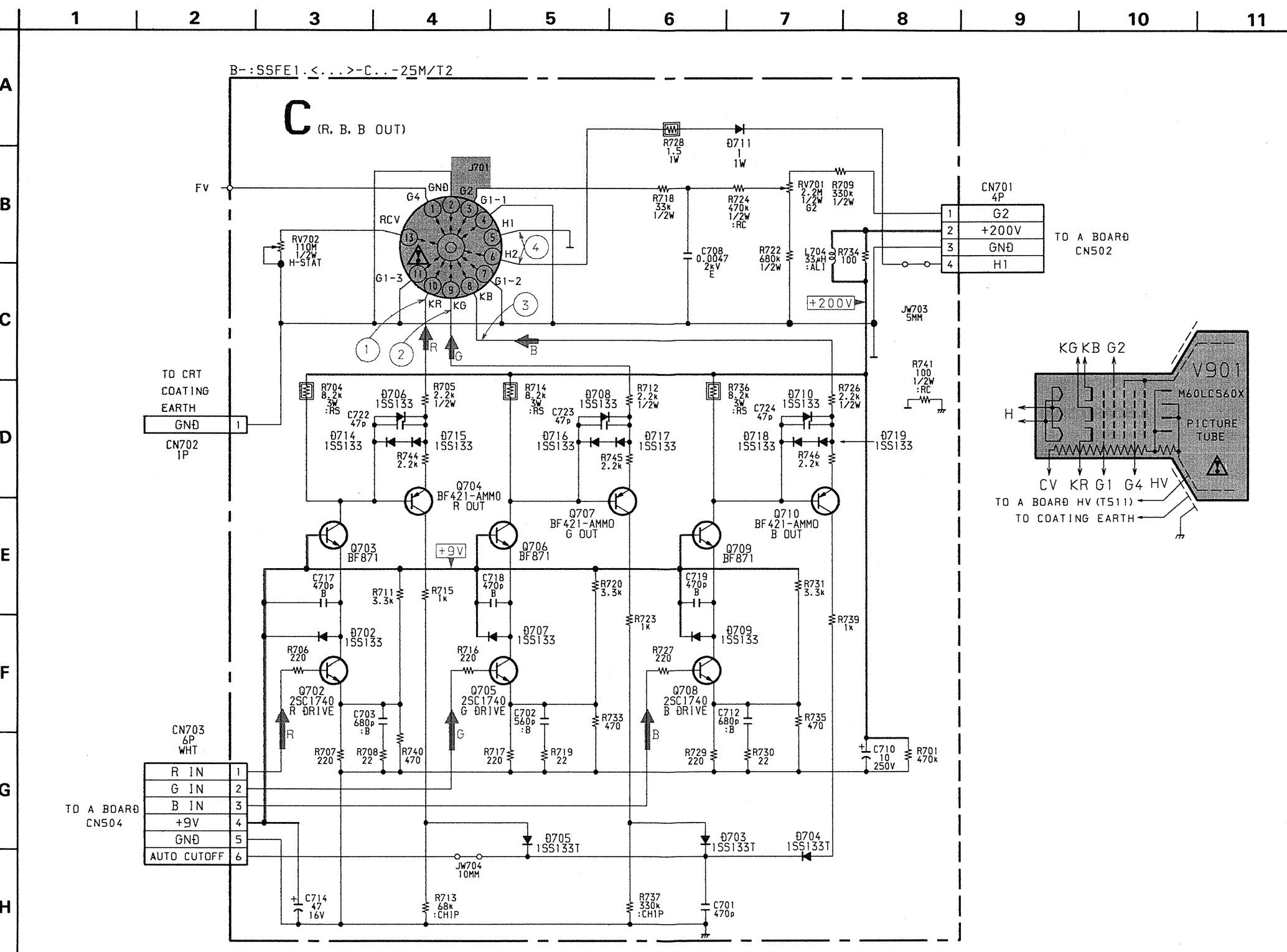
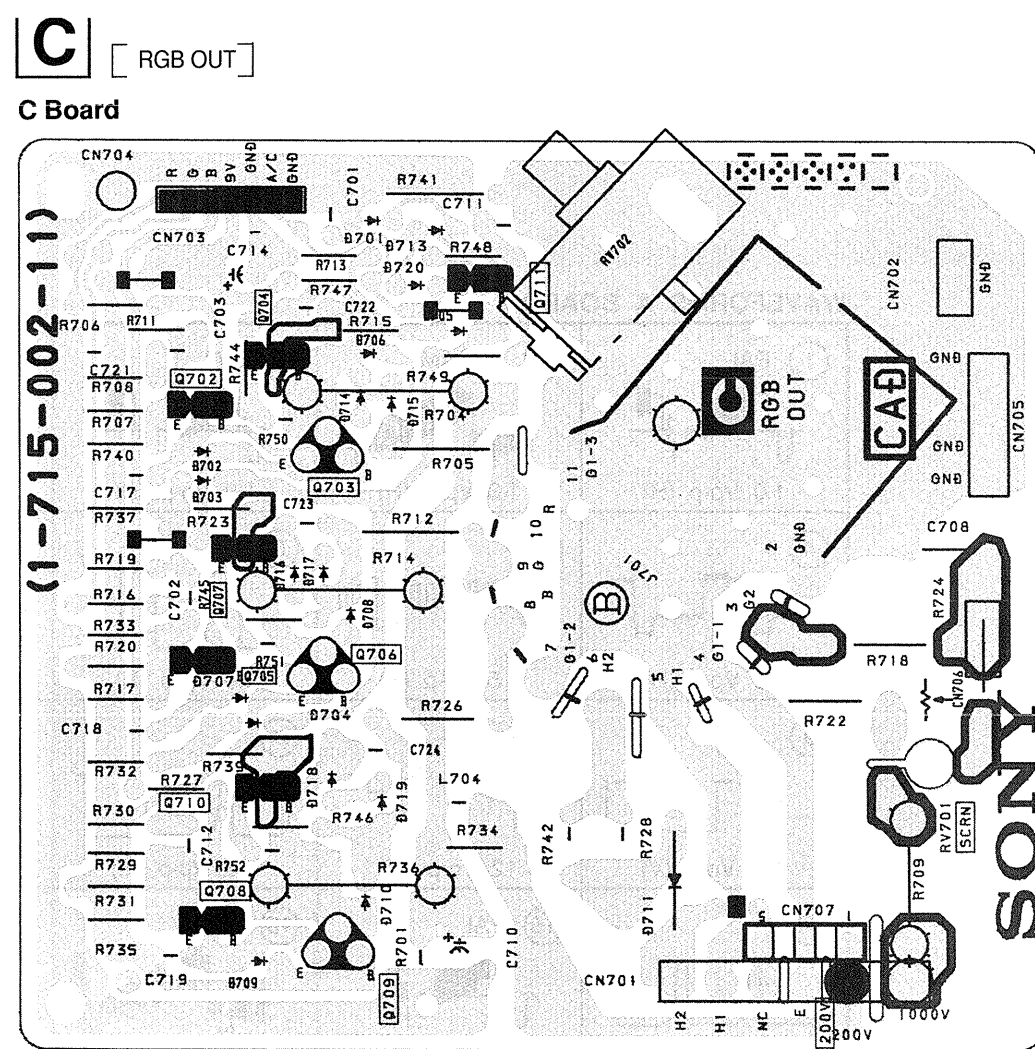

C BOARD TRANSISTOR VOLTAGE TABLE

Ref No	(B) Base	(C) Collector	(E) Emitter
Q702	1.5	8.3	1.1
Q703	8.8	169.8	8.3
Q704	169.5	1.9	209.5
Q705	1.5	8.3	1.1
Q706	8.8	170.7	8.3
Q707	170.5	1.9	215.7
Q708	1.5	8.3	1.0
Q709	8.9	171.3	8.3
Q710	171.2	1.9	206.3

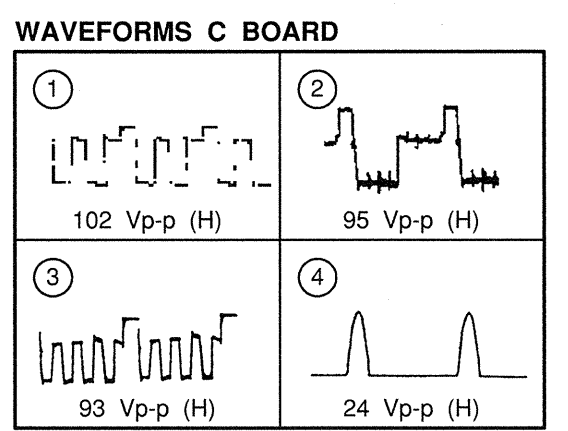

5-4 SEMICONDUCTORS

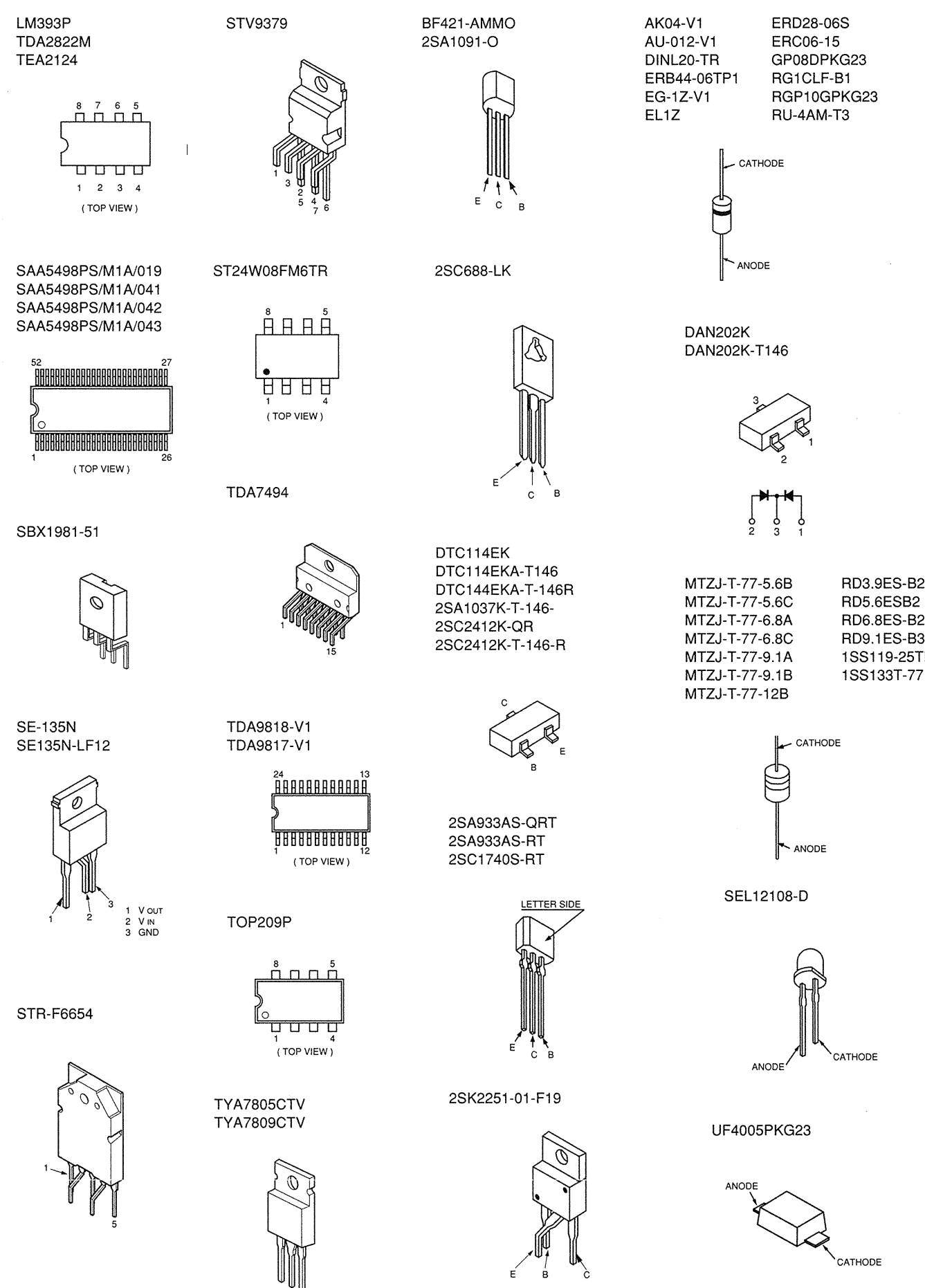

5-5. IC BLOCK DIAGRAMS

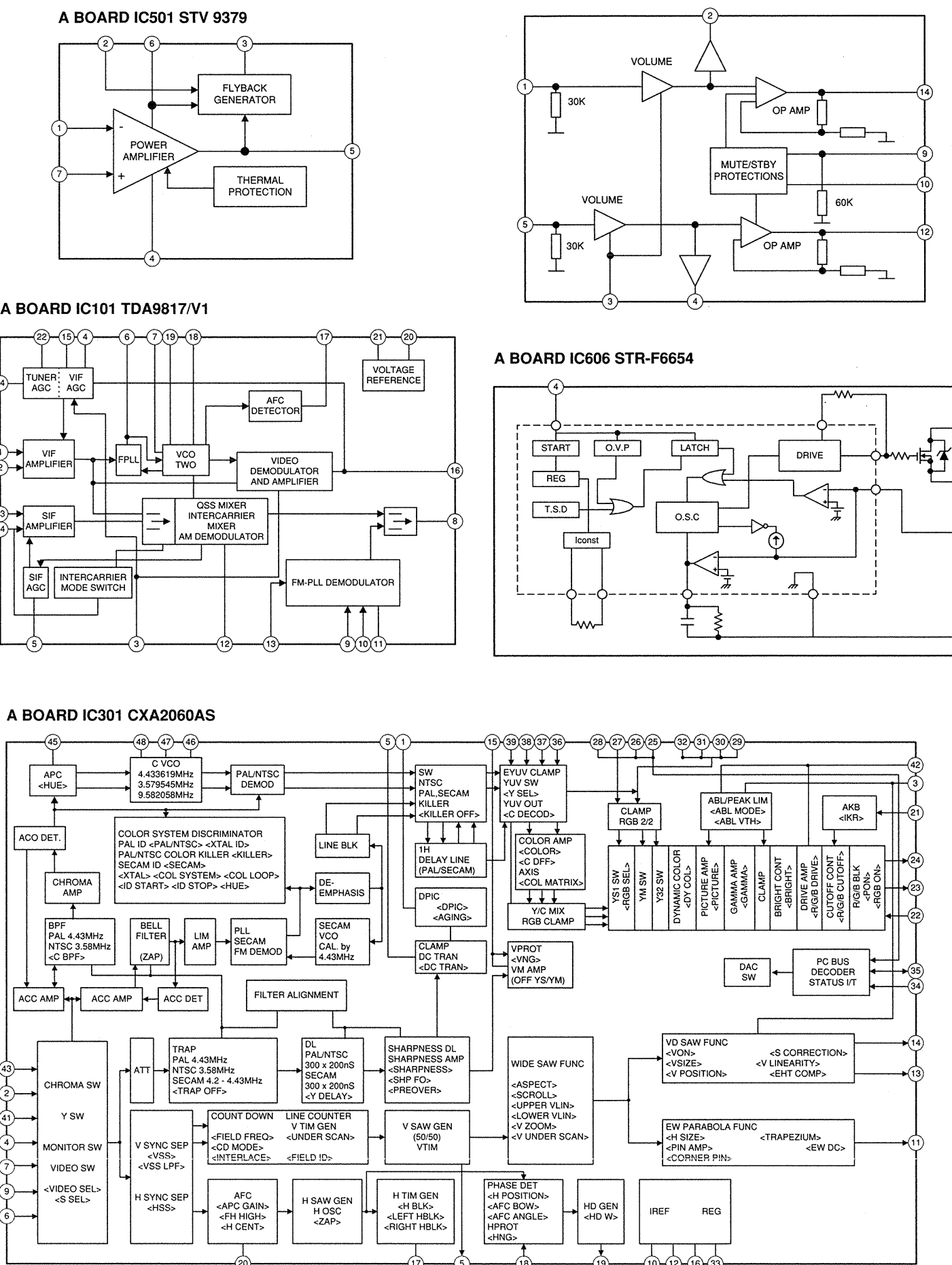

5-4 SEMICONDUCTORS

LM393P
TDA2822M
TEA2124

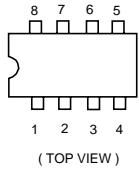

STV9379

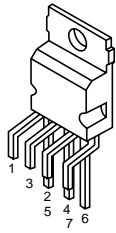

BF421-AMMO
2SA1091-O

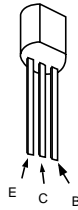

AK04-V1
AU-012-V1
DINL20-TR
ERB44-06TP1
EG-1Z-V1
EL1Z

ERD28-06S
ERC06-15
GP08DPKG23
RG1CLF-B1
RGP10GPKG23
RU-4AM-T3

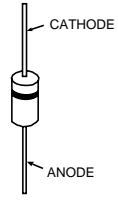

SAA5498PS/M1A/019
SAA5498PS/M1A/041
SAA5498PS/M1A/042
SAA5498PS/M1A/043

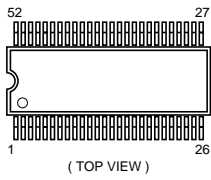

ST24W08FM6TR

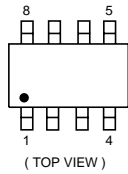

2SC688-LK

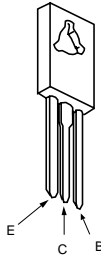

DAN202K
DAN202K-T146

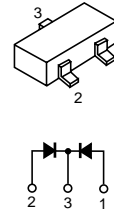

TDA7494

SBX1981-51

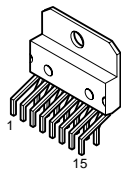
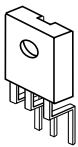

DTC114EK
DTC114EKA-T146
DTC144EKA-T-146R
2SA1037K-T-146-
2SC2412K-QR
2SC2412K-T-146-R

MTZJ-T-77-5.6B
MTZJ-T-77-5.6C
MTZJ-T-77-6.8A
MTZJ-T-77-6.8C
MTZJ-T-77-9.1A
MTZJ-T-77-9.1B
MTZJ-T-77-12B

RD3.9ES-B2
RD5.6ESB2
RD6.8ES-B2
RD9.1ES-B3
1SS119-25TD
1SS133T-77

SE-135N
SE135N-LF12

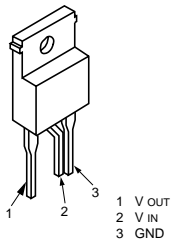

TDA9818-V1
TDA9817-V1

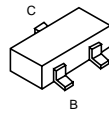
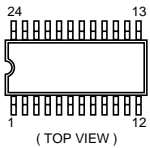

2SA933AS-QRT
2SA933AS-RT
2SC1740S-RT

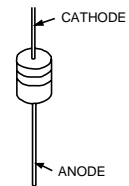

TOP209P

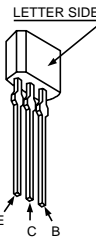
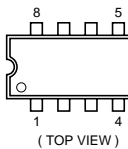

SEL12108-D

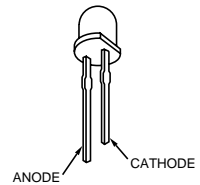

STR-F6654

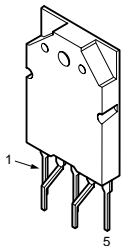

TYA7805CTV
TYA7809CTV

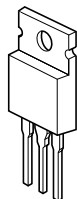

2SK2251-01-F19

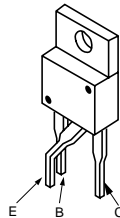

UF4005PKG23

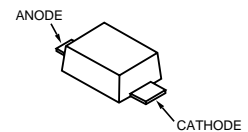

5-5. IC BLOCK DIAGRAMS

A BOARD IC501 STV 9379

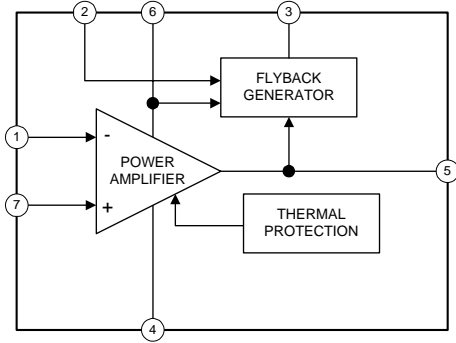

A BOARD IC201 TDA7495

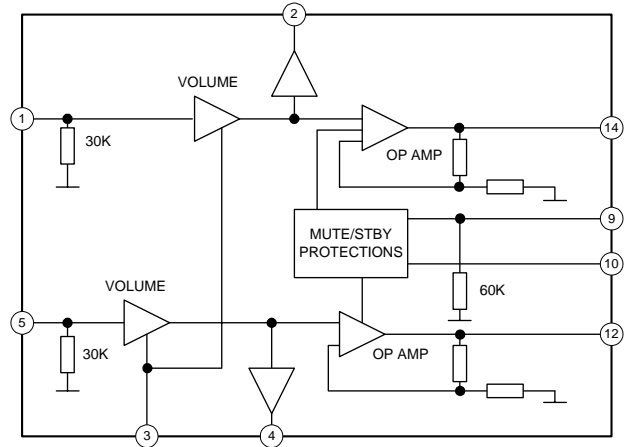

A BOARD IC101 TDA9817/V1

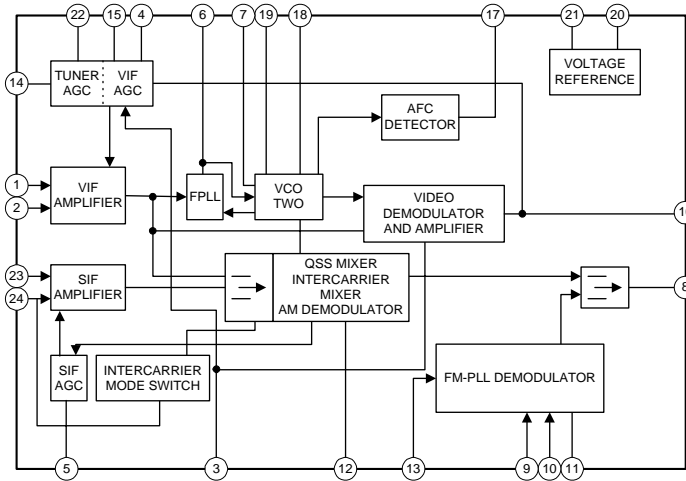

A BOARD IC606 STR-F6654

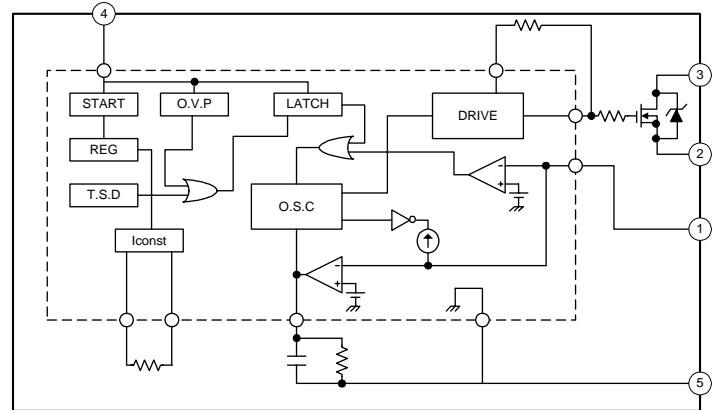

A BOARD IC301 CXA2060AS

