



## Easytec passive infrared detector

IR80B  
IR80UL

- **12m detection range with special fresnel lens**
- **Intelligent signal analysis**
- **Pet immunity up to 12kg**
- **Protected against insects and electromagnetic interference**
- **Temperature compensation**
- **Versatile in application**

Due to the ergonomic and discrete design, good pet immunity, as well as progressive signal evaluation, the IR80 is ideal for the residential sector.
- **Safe and easy installation**

The functional housing enables wall or corner mounting without accessories and offers sufficient wiring space. The detector base protects the electronics and the top-cover is simply snapped in.
- **Outstanding immunity**

The IR80 offers reliable catch performance with good immunity to pets up to 12kg and environmental influences such as air draughts, temperature fluctuations, electromagnetic interference and insects.
- **Safe detection**

Tanks to the specially developed Fresnel Lens high detection security is ensured. The signal evaluation guarantees good detection integrity by reliably differentiating between intruders and disturbance signals.

## Dimensions, coverage range and controls

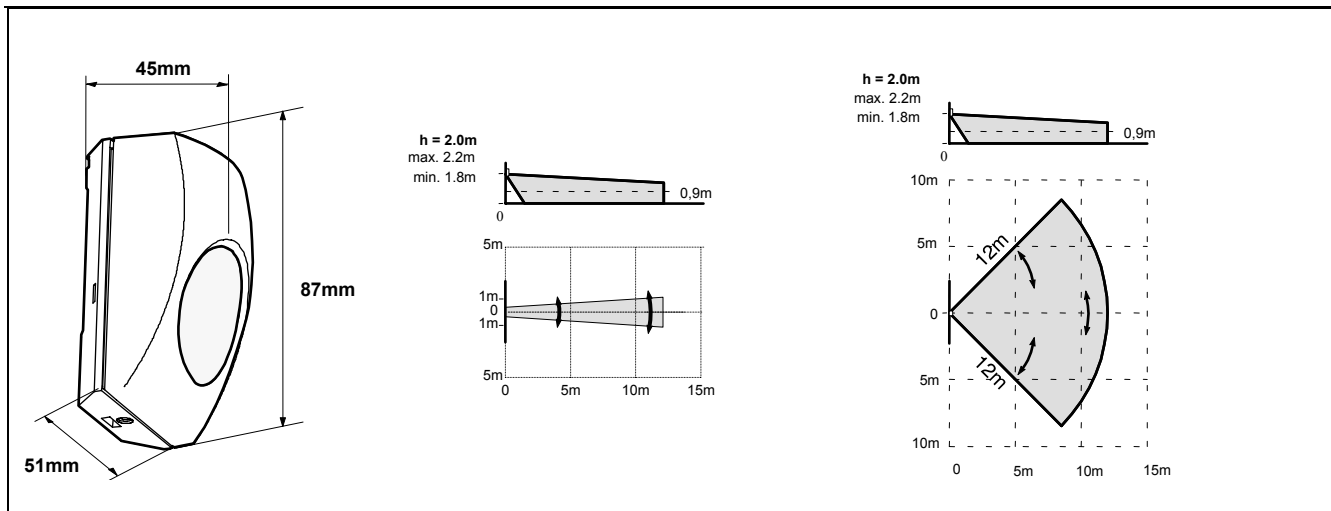

### Technical data

Supply voltage (12 V nom.)	9.0 ... 16.0 V <sub>DC</sub>
Max. ripple (0 ... 100 Hz)	2.0 V <sub>SS</sub>
Voltage monitoring	Alarm at < 6.0 ... 8.0 V
Current consumption (at 12 V <sub>DC</sub> )	
Quiescent	12 mA
Maximum when alarm occurs (with LED)	16 mA
Alarm output	
Relay contact (opens at alarm)	30 V <sub>DC</sub> / 100 mA / R 32 Ohm
Alarm holding time	2 ... 3 s
Walktest indicator	LED (on/off)
Tamper contact	30 V <sub>DC</sub> / 50 mA
Walking speeds	
Wide angel lens (standard)	0.3 ... 3.0 m/s
Curtain mask (covering foil)	0.3 ... 3.0 m/s
Pet immunity	< 12 kg
Ambient conditions	
Operation temperature	-20 ... +55 °C
Storage temperature	-20 ... +60 °C
Humidity (EN60721)	<95 % rF, non condensing
EMI rejection up to 2 GHz	10 V/m
Housing protection	IP41
EN60529, EN50102	

### Ordering data

Type	Art. No.	Designation	Weight
IR80B (1x1)	A5Q00002067	Passive infrared detector	0.070 kg
IR80UL (1x1)	A5Q00001768	Passive infrared detector	0.070 kg
IR80B	562962.0-001	Passive infrared detector	0.070 kg
IR80UL	562289.0-001	Passive infrared detector	0.070 kg
IRUM2	519876.0-001	Swivel wall-mount bracket	0.044 kg
IRUM3	519889.0-001	Swivel ceiling mount bracket	0.072 kg