

**SERVICE**

**MANUAL**

P U B L I C A D D R E S S

**AMPLIFIER**

**A-60/120**

**interM**

www.inter-m.com  
MADE IN KOREA  
NO: 9007985000

**interM**

# ELECTRICAL ADJUSTMENT PROCEDURE

## ■ AMP SECTION

### 1. OFF SET VOLTAGE

- A. Setting  
Set the master volume control minimum.
- B. Connection

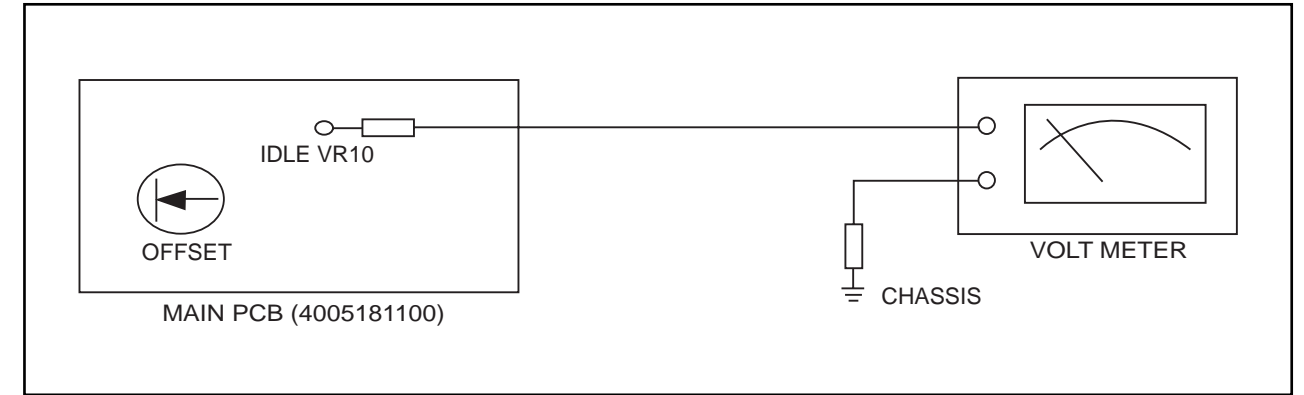

- C. Adjustment  
Control OFFSET until voltmeter is the "0" position. (at Output Terminal)

### 2. IDLE CURRENT

- A. Setting  
Set the master volume control minimum.
- B. Connection

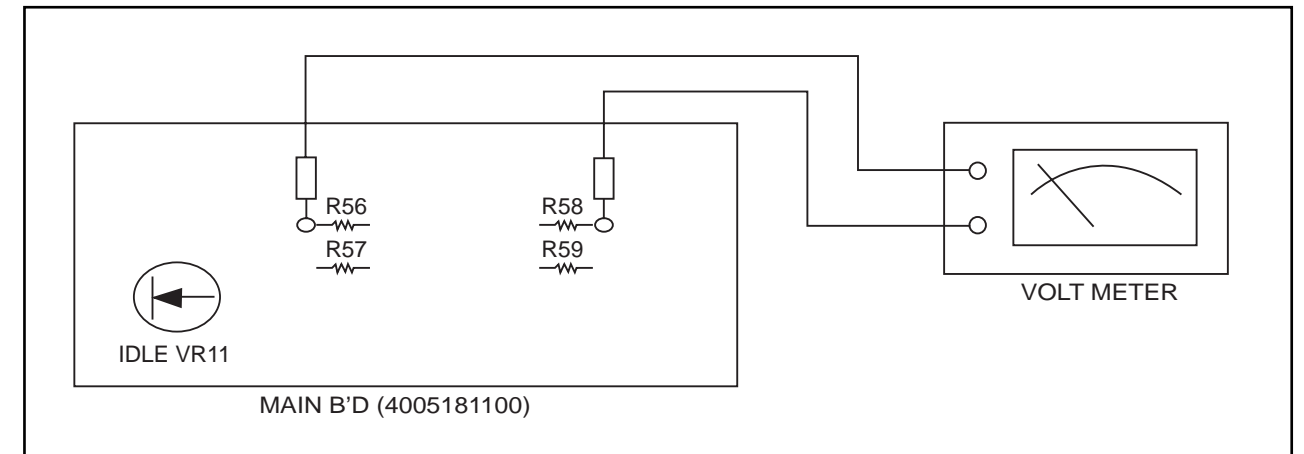

- C. Adjustment
  - A-60: Adjust VR11 so that the current through the R56 and R58 become 10 milliamperes. When that voltage is 10 millivolt, the current becomes 10 milliamperes.
  - A-120: Adjust VR11 so that the current through the R56 and R58 become 5 milliamperes. When that voltage is 5 millivolt, the current becomes 10 milliamperes.

## CONTENTS

Electrical Adjustment Procedure . . . . .	1
Specifications . . . . .	2
Electrical Parts List . . . . .	3, 4
Top and Bottom View of P.C. Board . . . . .	5
Wiring Diagram . . . . .	6
Block Diagram . . . . .	7
Schematic Diagram . . . . .	8, 9
Exploded View of Cabinet & Chassis / Mechanical Parts List . . . . .	10, 11
Ass'y Drawing . . . . .	12, 13

# SPECIFICATIONS

## ELECTRICAL

- Rated Output/Impedance .....A-60: 15.5V/4Ω, 70V/81.6Ω, 100V/166.7Ω  
A-120: 21.9V/4Ω, 70V/40.8Ω, 100V/83.3Ω
- Input Sensitivity/Impedance
  - MIC 1-3..... -60dB/600Ω, BAL
  - Aux 1 ..... -10dB/10kΩ, UNBAL
  - Aux 2 ..... +3dB/10kΩ, UNBAL
- Frequency Response (±3dB).....80Hz~16kHz
- T.H.D.....Less than 1%
- S/N
  - MIC .....Better than 50dB
  - Aux.....Better than 75dB
- Tone Control
  - HIGH (10kHz).....±12dB
  - LOW (100Hz) .....±12dB

## GENERAL

- Power Source .....AC 100V~240V, 50/60Hz
- Power Consumption .....A-60: 75W  
A-120: 105W
- Weight.....A-60: 8.9kg  
A-120: 10.3kg
- Dimensions.....420(W) × 88(H) × 320(D)mm

\*Specifications and design subject to change without notice for improvements.

# ELECTRICAL PARTS LIST

Ref No.	Part No.	Description	Value
<b>MAIN B'D (4005181100)</b>			
Q16-17	2008206998-T	TR PNP 2SA 965Y(KTA 1023Y)	2SA 965Y
Q18-19	2008407970-T	TR NPN KTC 2SC 2235Y(KTC1027Y)	2SC 2235Y
Q21 Q106	2008606104-T	TR NPN KTC 3198Y	KTC 3198Y
Q22	2008606105-T	TR PNP KTA 1266Y	KTA 1266Y
Q12-15 Q20	2008606108-T	TR NPN KTC2240BL (KTC 3200BL)	KTC 2240BL
Q100	2008606998-T	TR NPN KTD 1302 KEC ONLY	KTD1302
Q101-103	2008606998-T	TR NPN KTD 1302 KEC ONLY	KTD 1302
Q8(A60)	2028107106	TR PNP 2SB688(O)/2SA1940	2SB 688
Q8-9(A120)	2028107118	TR PNP 2SA1943 TOSHIBA	2SA1943
Q11	2028107984	TR PNP 2SA 1306A(Y),KTA1659A(Y)	KTA 1659A
Q6(A60)	2028407109	TR NPN 2SC5197 TOSHIBA	2SD 718
Q6-7(A120)	2028407122	TR NPN 2SC5200 TOSHIBA	2SC5200
Q10	2028407990	TR NPN 2SC 3298A(Y),KTC4370A(Y)	KTC 4370A
D16-17	2058010101	DIODE IN 60	1N 60
D100	2058100103	DIODE KBPC-2504(SB256)LUG TYPE	KBPC2504
D14	2058100996	DIODE RECTIFIER LT1N4006(4007)	1N 4006
D15 D101-104	2058100996	DIODE RECTIFIER LT1N4006(4007)	1N4006
D10-13	2058304100	DIODE IN4148M	1N 4148
D105-106			
ZD109	2058502120	DIODE ZENER UZ-12BM(1N5242B)	UZ-12BM
IC111-112	2118030405	IC KEC KIA 6966S	KIA6966S
IC8	2118050410	IC TA7317P TOSHIBA	TA 7317P
IC101	2128611000	IC KA7818 COMMON	7818
IC102	2128611100	IC KA7918 COMMON	7918
TH1-2	2438209011	THERMISTOR YSG-503J L=100MM	50K
R77	3009101973	RES CF 100 1/5W J N	100
R71-72 R81	3009102973	RES CF 1K 1/5W J N	1K
R69 R74-76	3009103973	RES CF 10K 1/5W J N	10K
R93 R187	3009104973	RES CF 100K 1/5W J N	100K
R68 R86-87	3009152973	RES CF 1.5K 1/5W J N	1.5K
R88 R96	3009153973	RES CF 15K 1/5W J N	15K
R98 R92			
R65 R83	3009182973	RES CF 1.8K 1/5W J N	1.8K
R66	3009203973	RES CF 20K 1/5W J N	20K
R78-79	3009221973	RES CF 220 1/5W J N	220
R97	3009224973	RES CF 220K 1/5W J N	220K
R90	3009302973	RES CF 3K 1/5W J N	3K
R99	3009333973	RES CF 33K 1/5W J N	33K
R73	3009471973	RES CF 470 1/5W J N	470
R70 R95	3009473973	RES CF 47K 1/5W J N	47K
R80	3009562973	RES CF 5.6K 1/5W J N	5.6K
R89 R91 R94	3009563973	RES CF 56K 1/5W J N	56K
R100			
R67	3009821973	RES CF 820 1/5W J N	820
R62	3039103575-T	RES MO 10K 2W JR	10K 2W
R63	3039152575-T	RES MO 1.5K 2W J RADIAL	1.5K 2W
R60-61	3039203473-F	RES MO 20K 1W JN	20K 1W
R64	3039271575-T	RES MO 270 2W J RADIAL	270 2W
R101-102	3059100772	RES CE 10 5W JN	10/5W
R54(A60)	3009392973	RES CF 3.9K 1/5W J N	3.9K
R54(A120)	3009152973	RES CF 1.5K 1/5W J N	1.5K
R9(A60)	3009822973	RES CF 8.2K 1/5W J N	8.2K
R9(A120)	3009562973	RES CF 5.6K 1/5W J N	5.6K
R82(A60)	3009103973	RES CF 10K 1/5W J N	10K
R82(A120)	3009133973	RES CF 13K 1/5W J N	13K
R84-85(A60)	3009123973	RES CF 12K 1/5W J N	12K
R84-85(A120)	3009203973	RES CF 20K 1/5W J N	20K
R56-59(A60)	3049478783	RES CE 0.47 5W J T HAN NAE	0.47/5W
R56-59(A120)	3059278783	RES CE 0.27 5W J T	0.27/5W
VR9	3228082210	VR RK09K111083MA	10KB
VR10-11	3248347120-T	SES SEMI RH0638C100471	470B
C103-104	3408222261	CAP RSA 2200UF 35V SNAP 18 P	2200/35
C75-76 C79	3409210071-T	CAP AF RSG 10UF 50V 5 P	10/50
C105-106	3409210141-T	CAP AF RSG 100UF 25V 6 P	100/25
C71 C119	3409210971-T	CAP AF RSG 1UF 50V 5 P	1/50
C128 C139			
C142 C144			
C147 C151			
C154-155			
C80	3409222071-T	CAP AF RSG 22UF 50V 5 P	22/50
C77	3409233071-T	CAP AF RSG 33UF 50V 6 P	33/50

Ref No.	Part No.	Description	Value
C72-74 C81	3409247071-T	CAP AF RSG 47UF 50V 6 P	47/50
C117-118			
C137-138			
C149-150			
C152 C159			
C78	3409247871-T	CAP AF RSG 0.47UF 50V 5 P	0.47/50
C112-113	3409247971-T	CAP AF RSG 4.7UF 50V 5 P	4.7/50
C123-124			
C132-133			
C202-205			
C67 C69-70	3509101130-T	CAP CE SL 100PF 50V J	100P
C111	3509102530-T	CAP CE B 0.001UF 50V J	0.001/50
C1 C68	3509103530-T	CAP CE F 0.01UF 50V Z	0.01/50
C107-108	3509104530-T	CAP CE F 0.1UF 50V Z	0.1/50
C66	3509470130-T	CAP CE SL 47PF 50V J	47P
C157	3609103120-T	CAP MA 0.01UF 100V	0.01/100(M)
C300-301	3609104120-T	CAP MA 0.1UF 100V J	0.1/100(M)
C303-304			
C156 C158			
C65	3609182120-T	CAP MA 0.0018UF 100V J	0.0018/100(M)
C101-102(A60)	3419533279	CAP LSW332M 1HO25M(3300UF/50V)	3300/6.3
C101-102(A120)	3419510379	CAP E LPW103HJP63V-WGB3 JAMIC	10000/50
FB101-106	3908609990	EMI FILTER 1000PF	EMI 1000P
IDLE1-3	4355469103	WIRE JUMPER	JUMPER
WAF9	4428595003	LW5267/LWB0640/2.5MM-03P	LW-5267-03P
WAF5	4428595004	LW5267/LWB0640/2.5MM-04P	LW-5267-04P
WAF7-8	4428595005	LW5267/LWB0640/2.5MM-05P	LW-5267-05P
WAF4	4428595005	LW5267/LWB0640/2.5MM-05P	LW-5267-05P
WAF3	4428596602	WAFER LW-1143-02P	LW-1143-02P
WAF1-2	4428596603	LOCK WAFER LW-1143-03P	LW-1143-03P
AUX1-2	4438095210	JACK RCA 4P	RCA 4P
MIC1-3	4438097310	JACK PHONE 4P	PHONE 4P
F101-102	5508411934	FUSE TS 20MM 630MA/250V U/C/S	T630mA/250V
RLY1	5528008200	RELAY DH24D1-0 24V (DAIICHI)	HR-311
IC103-105	S21101080002	IC 2068 SOIC8	NJM 2068DD
R109-110	S30101017121	RES TF 100 1/16W 1608	100
R123-124			
R135-136			
R184			
R113-114	S30101027121	RES TF 1K 1/16W 1608	1K
R119-120			
R105-106	S30101027121	RES TF 1K 1/16W 1608	1K
R103-104	S30101037121	RES TF 10K 1/16W 1608	10K
R111-112			
R117-118			
R127			
R132 R146			
R185-186	S30101047121	RES TF 100K 1/16W 1608	100K
R128	S30101137121	RES TF 11K 1/16W 1608	11K
R139	S30101237121	RES TF 12K 1/16W 1608	12K
R107 R108	S30101247121	RES TF 120K 1/16W 1608	120K
R115 R121	S30101847121	RES TF 180K 1/16W 1608	180K
R116 R122			
R188	S30102037121	RES TF 20K 1/16W 1608	20K
R125-126	S30102217121	RES TF 220 1/16W 1608	220
R130-131			
R137	S30102237121	RES TF 22K 1/16W 1608	22K
R138	S30102247121	RES TF 220K 1/16W 1608	220K
R141	S30102257121	RES TF 2.2M 1/16W 1608	2.2M
R190 R193	S30103317121	RES TF 330 1/16W 1608	330
R143	S30103337121	RES TF 33K 1/16W 1608	33K
R142	S30103937121	RES TF 39K 1/16W 1608	39K
R129 R134	S30104727121	RES TF 4.7K 1/16W 1608	4.7K
R191 R133	S30104737121	RES TF 47K 1/16W 1608	47K
R140 R145			
R144 R192	S30105637121	RES TF 56K 1/16W 1608	56K
R147	S30105647121	RES TF 560K 1/16W 1608	560K
R189	S30108237121	RES TF 82K 1/16W 1608	82K
C110 C121-122	S35101025321	CAP CL 0.001UF 50V K 1608	0.001/50
C130 C141			
C146 C131			
C143 C148	S35100504321	CAP CL 5PF 50V J 1608	5P
C114 C125	S35101504321	CAP CL 15PF 50V J 1608	15P
C134			
C126 C127	S35103304321	CAP CL 33PF 50V J 1608	33P
C135-136			



Ref No.	Part No.	Description	Value
C153	S35104704321	CAP CL 47PF 50V J 1608	47P
C115 C116	S35106804321	CAP CL 68PF 50V J 1608	68P
<b>VOLUME B'D (4005181110)</b>			
VR6-7	3228069180	RK09S11F010353B	50KB
VR1-5 VR8	3228069190	RK09S11B000313A	10KA
C164 C167	3409210071-T	CAP AF RSG 10UF 50V 5 P	10/50
C165 C168	3409210071-T	CAP AF RSG 10UF 50V 5 P	10/50
C160	3409222071-T	CAP AF RSG 22UF 50V 5 P	22/50
C172 C178	3409233071-T	CAP AF RSG 33UF 50V 6 P	33/50
C162-163	3409247071-T	CAP AF RSG 47UF 50V 6 P	47/50
C170-171			
C173	3609102120-T	CAP MA 0.001UF 100V	0.001/100(M)
C175-176	3609103120-T	CAP MA 0.01UF 100V	0.01/100(M)
C174	3609152120-T	CAP MA 0.0015UF 100V J	0.0015/100(M)
CON9	4355740621	CON ASS' Y 3P 510MM A-60/120	CON ASS' Y 3P (510MM)
CON7	4355743319	CON ASS' Y 5P (450MM) A-60/120	CON ASS' Y 5P (450MM)
CON8	4355764012	CON ASS' Y 5P (250MM) A-60/120	CON ASS' Y 5P (250MM)
IC106-107	S21101080002	IC 2068 SOIC8	NJM 2068DD
R151-152	S30101017121	RES TF 100 1/16W 1608	100
R158-159			
R156	S30101027121	RES TF 1K 1/16W 1608	1K
R157	S30101037121	RES TF 10K 1/16W 1608	10K
R165	S30101227121	RES TF 1.2K 1/16W 1608	1.2K
R200-205	S30101237121	RES TF 12K 1/16W 1608	12K
R208-209	S30101337121	RES TF 13K 1/16W 1608	13K
R210	S30101837121	RES TF 18K 1/16W 1608	18K
R148 R153	S30102727121	RES TF 2.7K 1/16W 1608	2.7K
R206-207	S30103927121	RES TF 3.9K 1/16W 1608	3.9K
R150 R155	S30104717121	RES TF 470 1/16W 1608	470
R149 R154	S30104737121	RES TF 47K 1/16W 1608	47K
C161 C166	S35100504321	CAP CL 5PF 50V J 1608	5P
C177	S35101004321	CAP CL 10PF 50V J 1608	10P
C169	S35101514321	CAP CL 150PF 50V J 1608	150P
<b>OUTPUT LED B'D (4005181120)</b>			
LD1 LD7-8	2308684231	LED REC KLR208 2'5 RED KEC	RED
LD2-6	2308684271	LED REC KLG208 2'5 GRE KEC	GREEN
CON5	4355740421	CON ASS' Y 4P 510MM A-60/120	CON ASS' Y 4P (510MM)
CON4	4355740521	CON ASS' Y 5P 510MM A-60/120	CON ASS' Y 5P (510MM)
R1-8	S30106817121	RES TF 680 1/16W 1608	680
<b>SP TERMINAL B'D (4005181130)</b>			
TER1	4408193904	TERMINAL BLOCK(M) 4P	TERMINAL BLOCK(M)4P
TER2	4408194004	TERMINAL BLOCK(F) 4P	TERMINAL BLOCK(F)4P
WAF6	4428596604	LOCK WAFER LW-1143-04P	LW-1143-04P
<b>POWER SW B'D (4005181140)</b>			
C100	3549472407	CAP DE2E3KH472MA4B	0.0047/400V
WAF11	4428596603	LOCK WAFER LW-1143-03P	LW-1143-03P
SW1	4648199920	SW POWER SDD1PASL011 A-60/120	POWER S/W
OPT1(A60)	2818086100	TRANS OUTPUT A-60	O.P.T
OPT1(A120)	2818086200	TRANS OUTPUT A-120	O.P.T
OPT1(A60UL)	2818085900	TRANS OUTPUT A-60(UL)	O.P.T
OPT1(A120UL)	2818086000	TRANS OUTPUT A-120(UL)	O.P.T
PT1(A60)	2828060000	TRANS POWER 120V A-60	120V
	2828060010	TRANS POWER 220V A-60	220V
	2828060020	TRANS POWER 230V A-60	230V
	2828060030	TRANS POWER 240V A-60	240V
PT1(A120)	2828059900	TRANS POWER 120V A-120	120V
	2828059910	TRANS POWER 220V A-120	220V
	2828059920	TRANS POWER 230V A-120	230V
	2828059930	TRANS POWER 240V A-120	240V
F100(A60)	5508112937	FUSE 51S 20MM 3A/250V K/U/C/J	120V
	5508212730	FUSE NB 20MM 2A/250V KS	220V
	5508412736	FUSE TS 20MM 2A/250V U/C/S/V	230V/240V
F100(A120)	5508103337	FUSE 53S 20MM 5A/250V K/U/C/J	120V
	5508112837	FUSE51S 20MM 2.5A/250V K/U/C/J	220V
	5508412836	FUSE TS 20MM 2.5A/250V U/C/S/V	230V/240V

# TOP AND BOTTOM VIEW OF P.C. BOARD

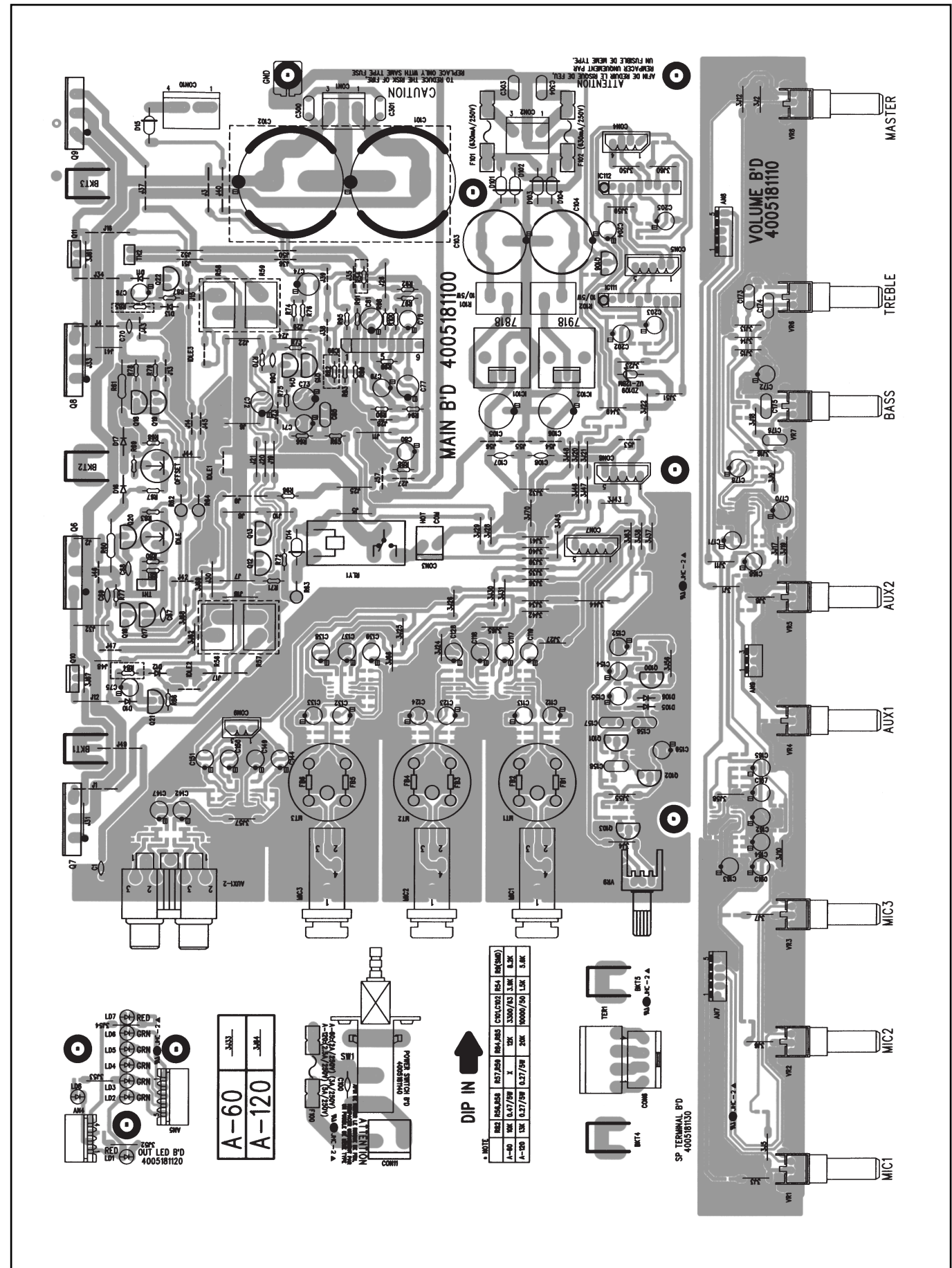

# WIRING DIAGRAM

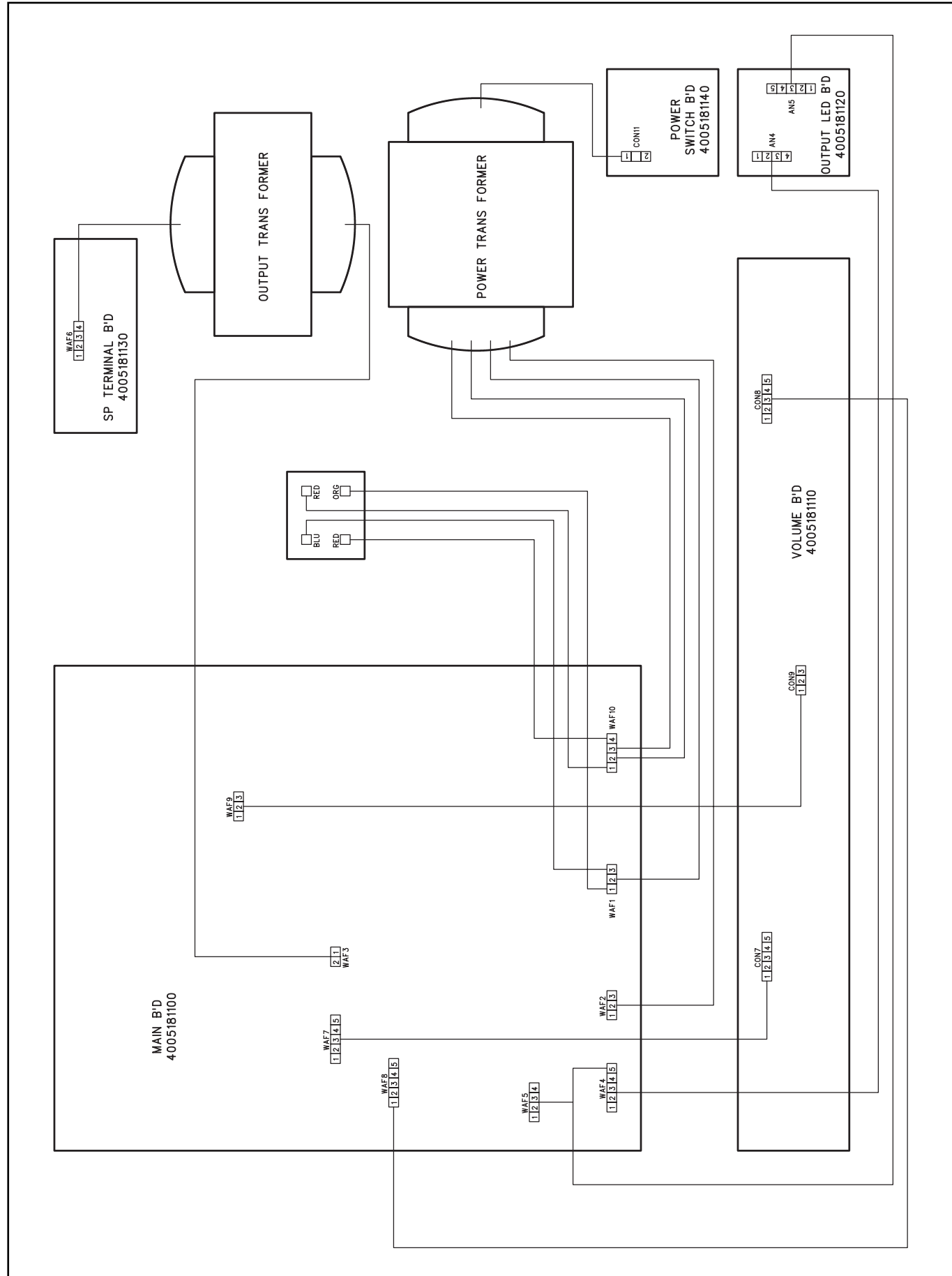

# BLOCK DIAGRAM

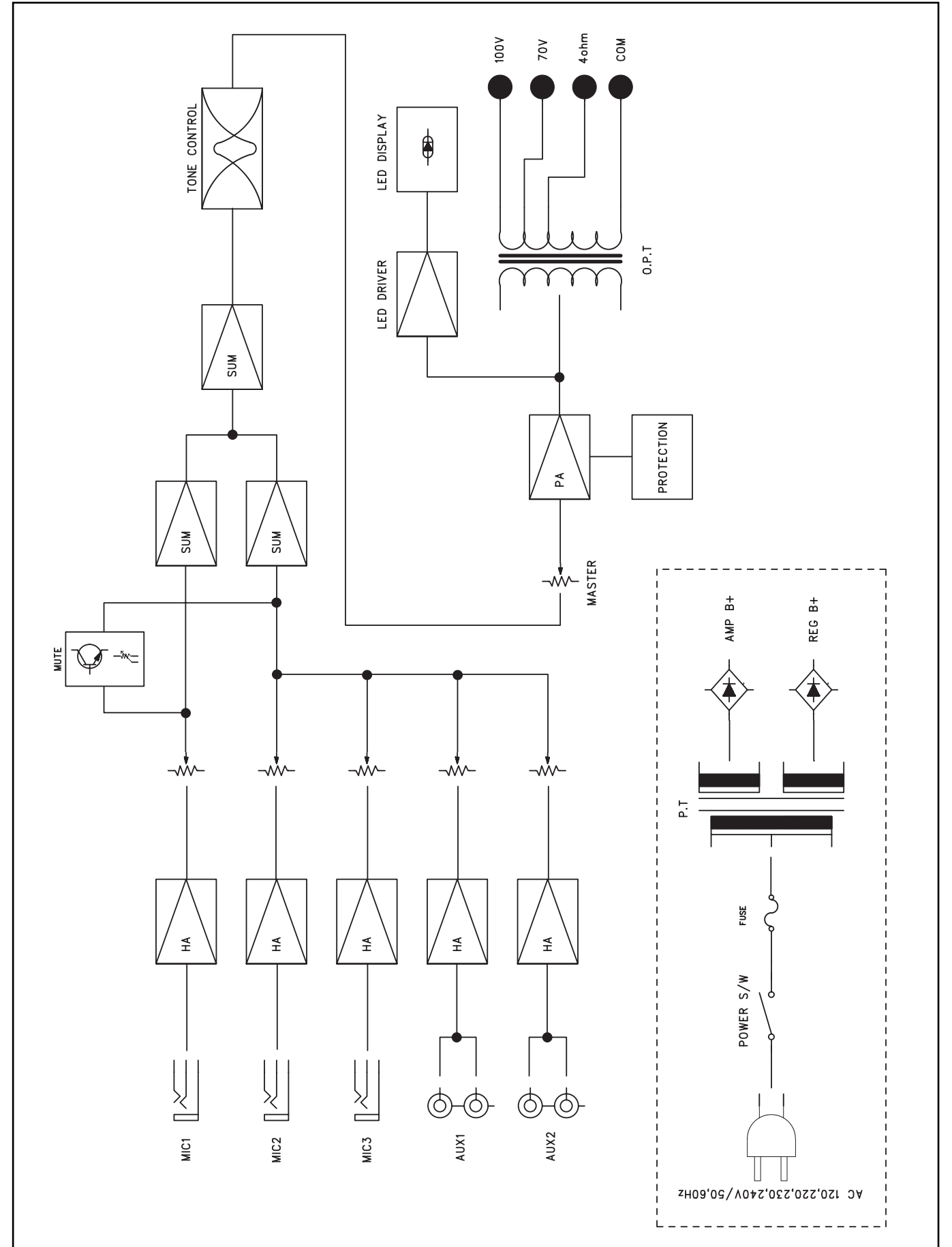

# SCHEMATIC DIAGRAM

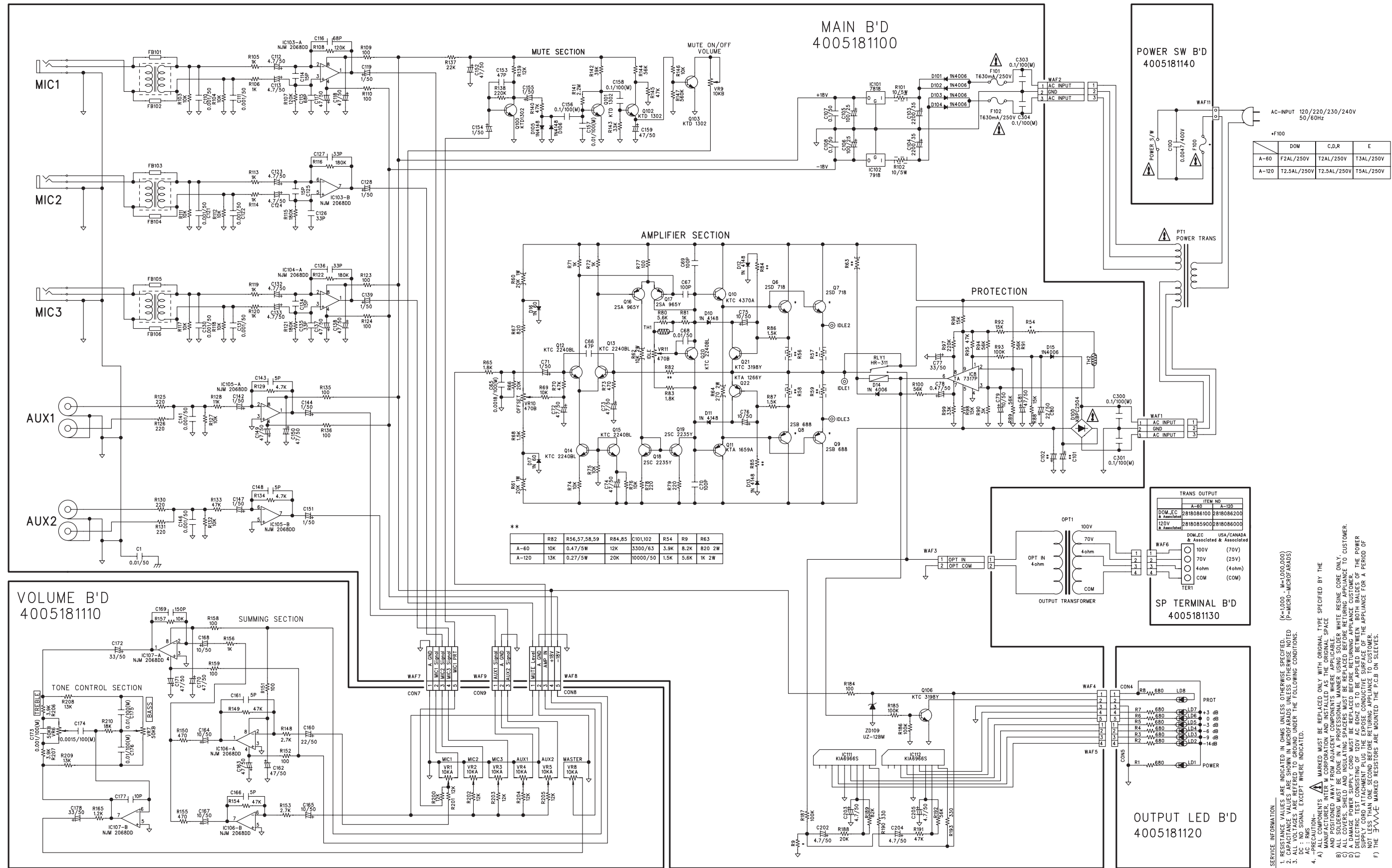



# EXPLODED VIEW OF CABINET & CHASSIS/MECHANICAL PARTS LIST

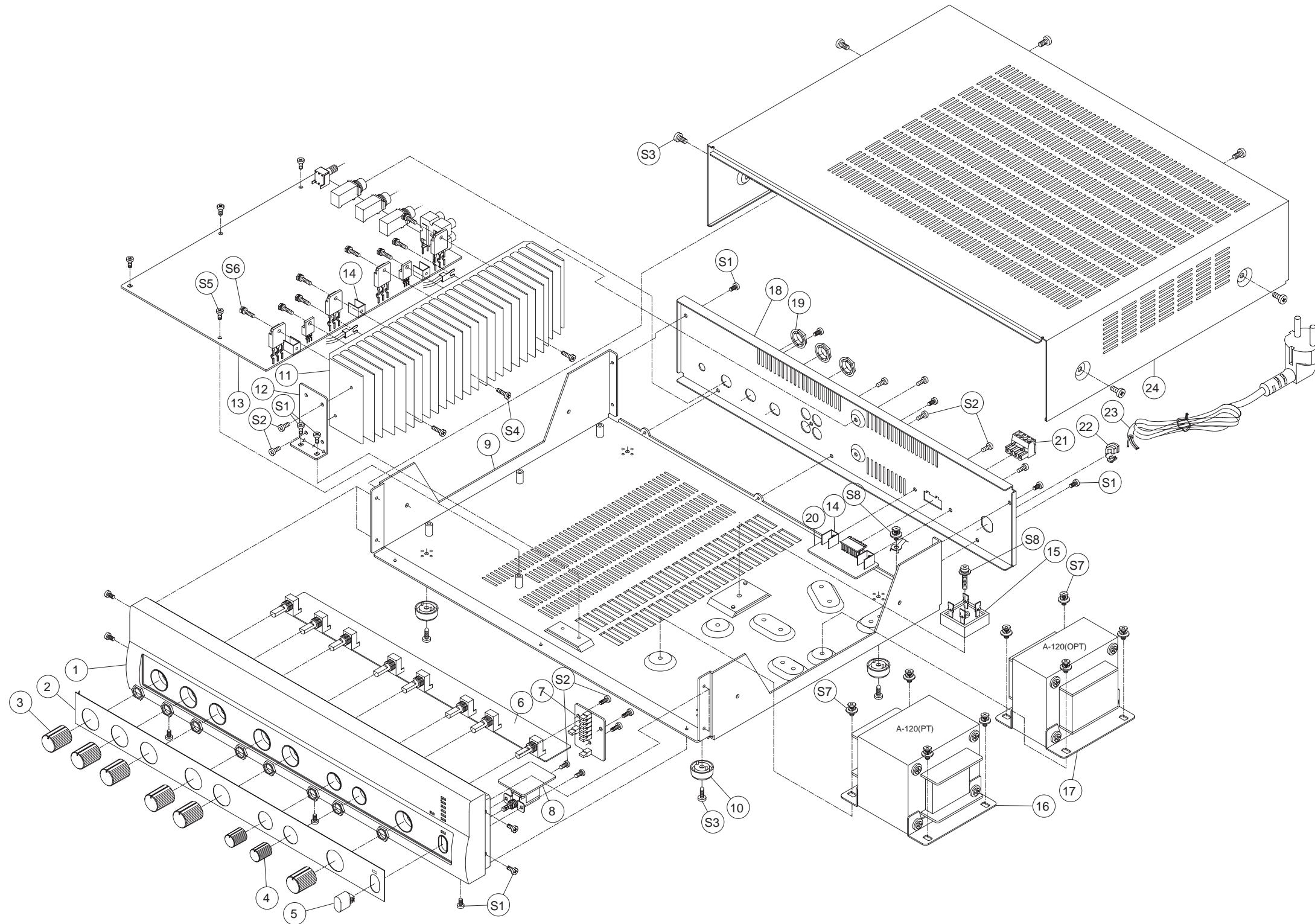

A-60/120 EXPLODED VIEW DWG PARTS, LIST

NO	PARTS NAME	PARTS NO	QTY	REMARK
1	FRONT PANEL	048521990611	1	A-60
2	INLAY	048521990612	1	A-120
3	KNOB CONTROL	048543998313	6	
4	KNOB CONTROL	048543997011	2	
5	KNOB PUSH	8543998110	1	
6	VOLUME B'D	4005181110	1	
7	OUTPUT LED B'D	4005181120	1	
8	POWER SW B'D	4005181140	1	
9	CHASSIS MAIN	6121674910	1	
10	FOOT	056335999520	4	
11	HEAT SINK	7502088710	1	
12	HEAT SINK BKT	6505942010	1	
13	MAIN B'D	4005181100	1	
14	BRACKET PCB	6505968010	1	
15	DIODE	2058100103	1	
16	TRANS POWER	2828060010	1	A-60
		2828059910	1	A-120
17	TRANS OUTPUT	2818086100	1	A-60
		2818086200	1	A-120
18	BACK CHASSIS	046102979011	1	A-60
		046102979015	1	A-120
19	JACK NUT	8525998410	3	
20	SP TERMINAL B'D	4005181130	1	
21	TERMINAL BLOCK(F)	4408194004	1	
22	STOPPER CORD	6518999810	1	
23	CORD AC DOM 3 CORE	4308999710	1	
24	TOP COVER	046122089610	1	
S1	SCREW #3BTC 3X6B	8109330063	14	
S2	SCREW #2BTC 3X8B	8109230083	12	
S3	SCREW #3BTC 4X8BK	8109340083	10	
S4	SCREW #2BTC 3X10B	8109230103	4	
S5	SCREW BM 3X6B	8009130063	3	
S6	HEX MSPW 3X16Y	8099130161	8	
S7	ASS'Y SCREW 3PTC 4X8B	8095993410	9	
S8	ASS'Y SCREW PM 4X18B	8095996930	1	

# ASS'Y DRAWING

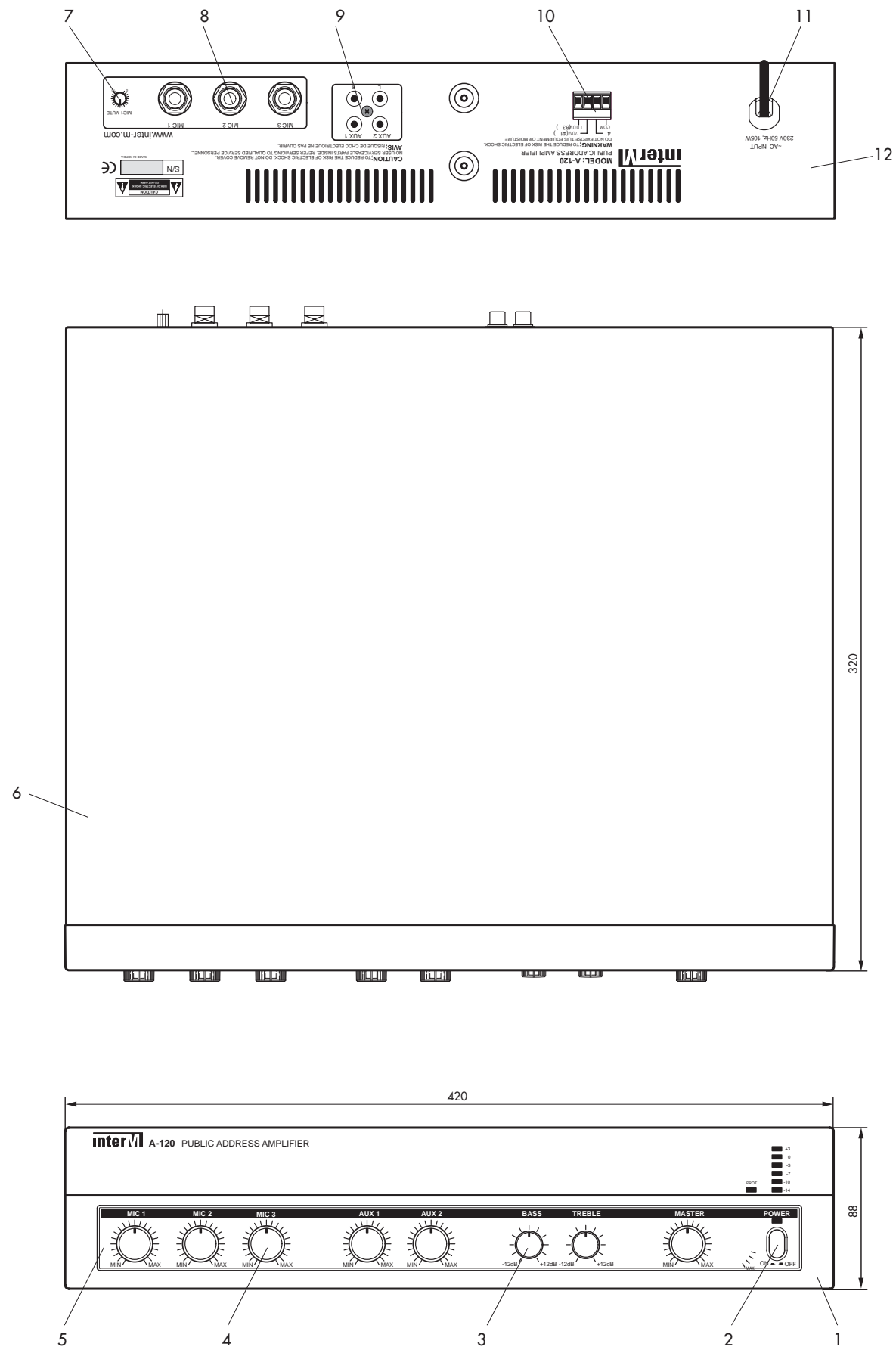

No.	Description	Part No	Q'ty	Remark
1	FRONT PANEL	048521990611	1	A-60
2	SW POWER	048521990612	1	A-120
3	CONTROL KNOB	048543997210	1	
4	CONTROL KNOB	048543998313	6	
5	INLAY	048573994111	1	
6	TOP COVER	046122089610	1	
7	CONTROL KNOB	048543997011	1	
8	PHONE JACK	4438097310	3	
9	RCA JACK 4P	4438095210	1	
10	SPEAKER TERMINAL	4408193904	1	
11	AC CORD	4308991710	1	
12	BACK CHASSIS	046102979011	1	A-60 220V
		046102979012	1	A-60 230V
		046102979013	1	A-60 120V
		046102979014	1	A-60 240V
		046102979015	1	A-120 220V
		046102979016	1	A-120 230V
		046102979017	1	A-120 120V
046102979018	1	A-120 240V		



