

Service Manual

Compact Disc Player
SL-EH50

Compact Disc Player

System: SC-EH50

For Europe and Russia

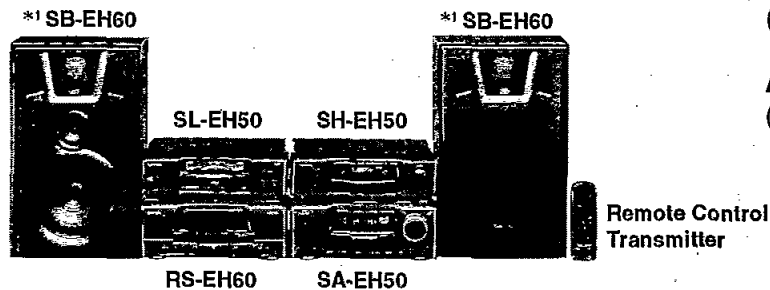

Colour
(K) ... Black

Area
(E)/(EP) ... Europe, Russia,
Asia, Latin America,
Middle East and
Africa.

For others

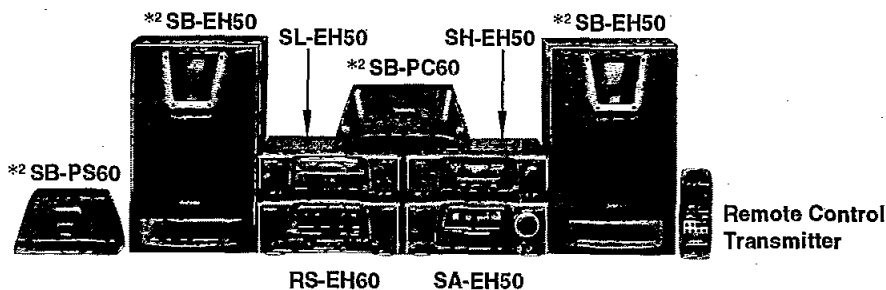

COMPACT
disc
DIGITAL AUDIO

MASH*3
multi-stage noise shaping

RAE0150Z MECHANISM SERIES

Because of unique interconnecting cables, when a component requires service, send or bring in the entire system.

Specifications

Audio Section

DA converter 1 bit DAC MASH

General

Dimensions 287(W)/89(H)/273(D) mm
Weight 1.6 kg

Pickup Section

Wavelength 780 nm

Notes: Specifications are subject to change without notice.
Weight and dimensions are approximate.

System/SC-EH50 :

For Europe and Russia

Sound processor : SH-EH50, Tuner/Amplifier : SA-EH50, Compact disc player : SL-EH50, Cassette deck : RS-EH60,
Front speakers : *1 SB-EH60

For others

Sound processor : SH-EH50, Tuner/Amplifier : SA-EH50, Compact disc player : SL-EH50, Cassette deck : RS-EH60,
Front speakers : *2 SB-EH50, Center speaker : *2 SB-PC60, Surround speaker : *2 SB-PS60

Notes: *1...Made in PAES
*2...Made in MESA
*3...MASH is a trademark of NTT

WARNING

This service information is designed for experienced repair technicians only and is not designed for use by the general public. It does not contain warnings or cautions to advise non-technical individuals of potential dangers in attempting to service a product. Products powered by electricity should be serviced or repaired only by experienced professional technicians. Any attempt to service or repair the product or products dealt with in this service information by anyone else could result in serious injury or death.

Technics®

© 1997 Matsushita Electric Industrial Co., Ltd.
All rights reserved. Unauthorized copying
and distribution is a violation of law.

Contents

	Page		Page
Handling Precautions for Traverse Deck	2	Type Illustration of IC's, Transistors and Diodes	20
Precaution of Laser Diode	2, 3	Wiring Connection Diagram	20
Location of Controls	3	Terminal Function of IC's	21 ~ 23
Listening to Compact Discs	4	Troubleshooting Guide	24, 25
Operation Checks and		Block Diagram	26, 27
Main Component Replacement Procedures	5 ~ 10	Replacement Parts List (Electrical)	28
Automatic Adjustment Results Display Function	11	Resistors and Capacitors	29, 30
To Supply Power Source	12	Replacement Parts List (Cabinet and Loading Unit)	31
Schematic Diagram	13 ~ 17	Cabinet Parts Location	32
Printed Circuit Board Diagram	18, 19	Loading Unit Parts Location	33

NOTE:

Refer to the service manual for Model No. SA-EH50 (ORDER No. AD970.053C8) for information on "Accessories", "Connections", "Installation" and "Packaging".

CAUTION:

THIS PRODUCT UTILIZES A LASER.
USE OF CONTROLS OR ADJUSTMENTS OR PERFORMANCE OF PROCEDURES OTHER THAN THOSE SPECIFIED HEREIN MAY RESULT IN HAZARDOUS RADIATION EXPOSURE.

Handling Precautions for Traverse Deck

The laser diode in the traverse deck (optical pickup) may break down due to potential difference caused by static electricity of clothes or human body. So, be careful of electrostatic breakdown during repair of the traverse deck (optical pickup).

• Handling of traverse deck (optical pickup)

1. Do not subject the traverse deck (optical pickup) to static electricity as it is extremely sensitive to electrical shock.
2. To protect the laser diode against electrostatic breakdown, short the flexible board (FFC board) with a clip or similar object.
3. Take care not to apply excessive stress to the flexible board (FFC board).
4. Do not turn the variable resistor (laser power adjustment). It has already been adjusted.

• Grounding for electrostatic breakdown prevention

1. Human body grounding
Use the anti-static wrist strap to discharge the static electricity from your body.
2. Work table grounding
Put a conductive material (sheet) or steel sheet on the area where the traverse deck (optical pickup) is placed, and ground the sheet.

Caution:

The static electricity of your clothes will not be grounded through the wrist strap. So, take care not to let your clothes touch the traverse deck (optical pickup).

Caution when Replacing the Traverse Deck:

The traverse deck has a short point shorted with solder to protect the laser diode against electrostatic breakdown. Be sure to remove the solder from the short point before making connections.

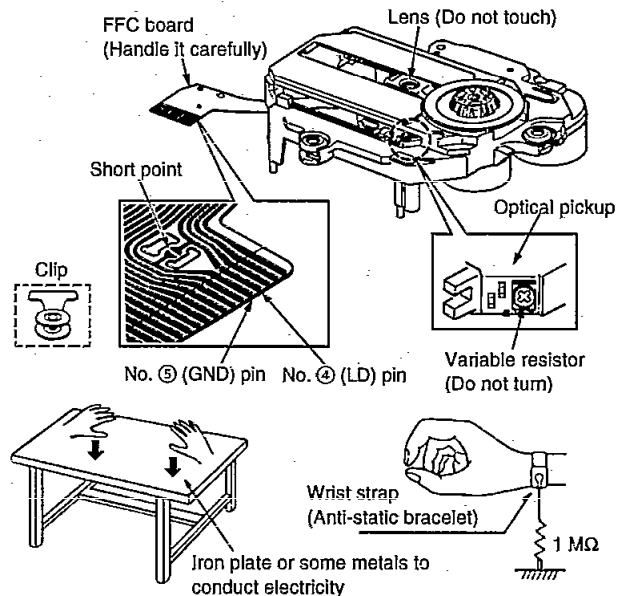

Precaution of Laser Diode

CAUTION: This product utilizes a laser diode with the unit turned "on", invisible laser radiation is emitted from the pick up lens.
Wave length: 780 nm
Maximum output radiation power from pick up: 100 μ W/VDE

Laser radiation from the pick up unit is safety level, but be sure the followings:

1. Do not disassemble the pick up unit, since radiation from exposed laser diode is dangerous.
2. Do not adjust the variable resistor on the pick up unit. It was already adjusted.
3. Do not look at the focus lens using optical instruments.
4. Recommend not to look at pick up lens for a long time.

ACHTUNG: Dieses produkt enthält eine laserdioden. Im eingeschalteten zustand wird unsichtbare laserstrahlung von der lasereinheit adgestrahlt.

Wellenlänge: 780 nm

Maximale strahlungsleistung der lasereinheit: 100 μ W/VDE

Die strahlung an der lasereinheit ist ungefährlich, wenn folgende punkte beachtet werden:

1. Die lasereinheit nicht zerlegen, da die strahlung an der freigelegten laserdioden gefährlich ist.
2. Den werksseitig justierten einstellregler der lasereinheit nicht verstellen.
3. Nicht mit optischen instrumenten in die fokussierlinse blicken.
4. Nicht über längere zeit in die fokussierlinse blicken.

**CLASS 1
LASER PRODUCT**

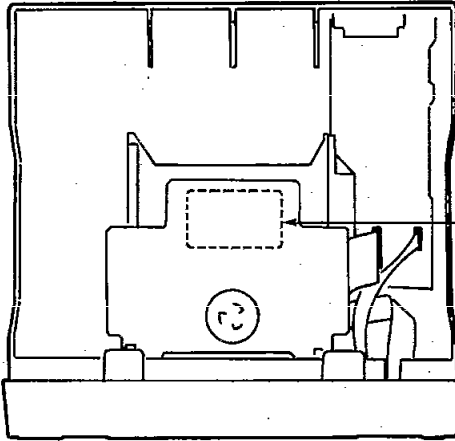
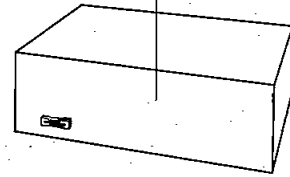

DANGER	THIS IS A LASER PRODUCT. NEVER OPEN AND INTERLOCK DEFEATED. AVOID EYE EXPOSURE TO BEAM.	(Inside of product)
ADVARSEL	ESKYLS LASERSTRÅL VED ÅBNING. NÅR SIKKERHEDSBRYDERNE ER UDE AF FUNKTION, UNDSÅ UDDELTELSE FOR STRÅL VÆ.	(Indersiden af apparatet)
VARO!	KÄYTTÄESSÄ LA SUVAUKSITUS OINTEIÄESSÄ CIET ALTIKKA KÄYTTÄÖNÄ LASERSÄTELYLLE. ÄLÄ KATSO GÄTSEEN.	(Tuotteen sisällä)
VARNING	ÖSKYLS LASERSTRÅL VED ÅBNING. NÅR SIKKERHEDSBRYDERNE ER UDE AF FUNKTION, UNDSÅ UDDELTELSE FOR STRÅL VÆ.	(Apparatens insida)
ADVARSEL	ESKYLS LASERSTRÅL VED ÅBNING. NÅR SIKKERHEDSBRYDERNE ER UDE AF FUNKTION, UNDSÅ UDDELTELSE FOR STRÅL VÆ.	(Produktets innside)
VORSICHT	TRUCKUTVÄRNE LASERSTRÅL VED ÅBNING. NÅR SIKKERHEDSBRYDERNE ER UDE AF FUNKTION, UNDSÅ UDDELTELSE FOR STRÅL VÆ.	(Im Inneren des Gerätes)

■ Location of Controls

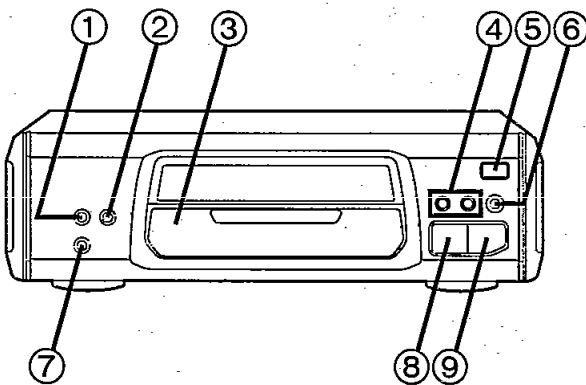

- ① Random play button (RANDOM)
- ② Repeat button (REPEAT)
- ③ Disc tray
- ④ Skip/search buttons (◀◀ / ◀, ▶▶ / ▶▶)
- ⑤ Disc tray open/close button (▲, OPEN/CLOSE)
- ⑥ Pause button (⏸)
- ⑦ AI edit button (AI EDIT)
- ⑧ Stop button (■)
- ⑨ Play button and indicator (▶)

■ Listening to Compact Discs

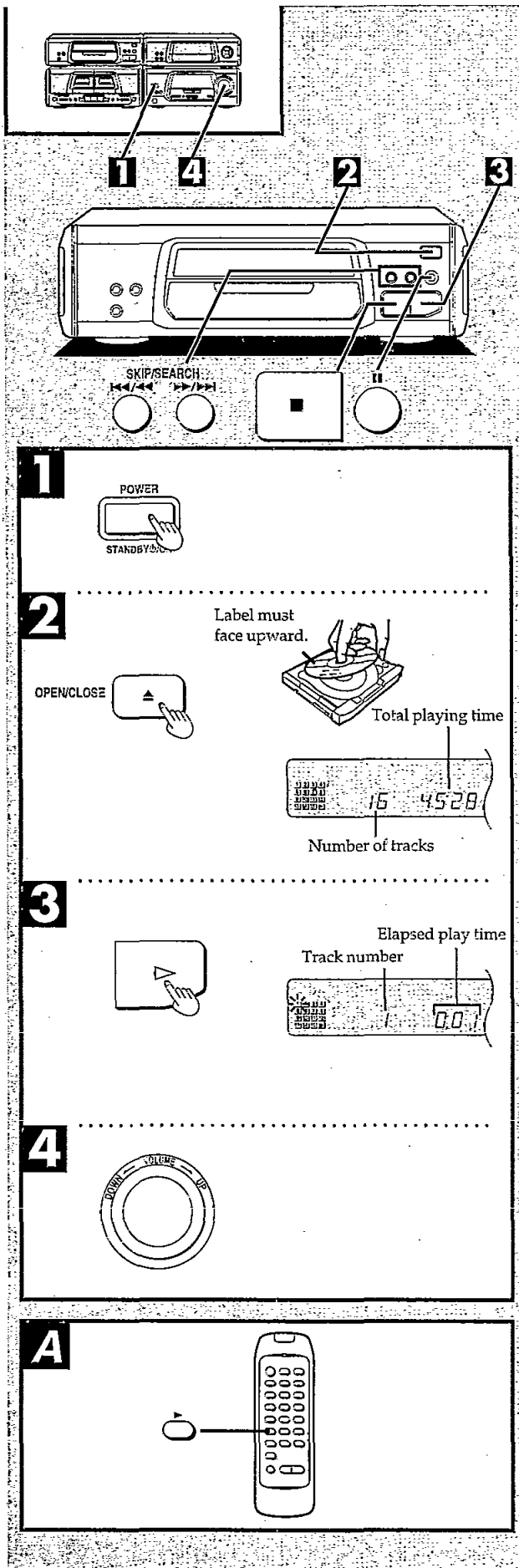

Sequential play

- 1** Switch on the power.
- 2** Press **▲ OPEN/CLOSE** to open the tray.
Insert the CD with label facing upward.

Press **▲ OPEN/CLOSE** to close the tray.
When the "CD" input source is selected, total number of tracks and total playing time will appear on the display.
When there are 16 or more tracks on the CD, "▶" will appear.
Note
The total playing time displayed when a disc is loaded includes intervals between tracks. This is why sometimes the displayed time is longer than that listed on the CD.
- 3** Press **▷**.
Play will start from the first track on the CD.
Play will stop automatically when the last track on the CD finishes playing.
- 4** Adjust the volume level as you like.

To stop the disc play:

Press **■**.

To temporarily stop the disc play:

Press **■**. The play indicator flashes green.

To play again, press **▷**.

When "NO DISC" display appears:

It indicates that a CD has not been installed.

About play indicator:

While halted: Lights up orange.

While playing: Lights up green.

For your reference:

If you press **▷** instead of **▲ OPEN/CLOSE** after inserting a CD, the tray will close and play will start directly from the track 1.

To search forward/ backward	Hold down during playback. [◀◀/▶▶] [▶▶/▶▶] (Backward) (Forward)
To skip forward/ backward	Press. [◀◀/▶▶] [▶▶/▶▶] (Backward) (Forward)

Note

During random play, you cannot skip to tracks which have already been played.

For your reference:

- During program play or random play, you cannot search-forward/backward over tracks.
- During program play, skipping is in always in the programmed order, whether forward or backward.

One-touch play **⏪**

When the system is OFF, playing starts automatically when you press **▶** on the remote control.

The play will start with volume increasing gradually.

Note

Do not use CDs with poorly attached labels or stickers. Adhesive protruding from underneath stickers or left over from peeled off stickers can cause the system to malfunction.

■ Operation Checks and Main Component Replacement Procedures

Warning: This product uses a laser diode. Refer to caution statements on page 2.

ACHTUNG: •Die Lasereinheit nicht zerlegen.

•Die Lasereinheit darf nur gegen eine vom hersteller spezifizizierte einheit ausgetauscht werden.

- NOTE**
1. This section describes procedures for checking the operation of the major printed circuit boards and replacing the main components.
 2. For reassembly after operation checks or replacement, reverse the respective procedures. Special reassembly procedures are described only when required.
 3. Select items from the following index when checks or replacement are required.
 4. Refer the parts No. on the page of "Main component Replacement Procedures", if necessary.

● Contents

• Checking Procedures for each P.C.B.	Page.
1. Checking for the main P.C.B.,	5,6.
2. Checking for the servo P.C.B. and operation P.C.B.,	6,7.
• Main Component Replacement Procedures	
1. Replacement for the traverse deck ass'y,	7~10.
2. Replacement for the belt, loading motor ass'y and loading switch,	10.

■ Checking Procedures for each P.C.B.

1. Checking for the main P.C.B.

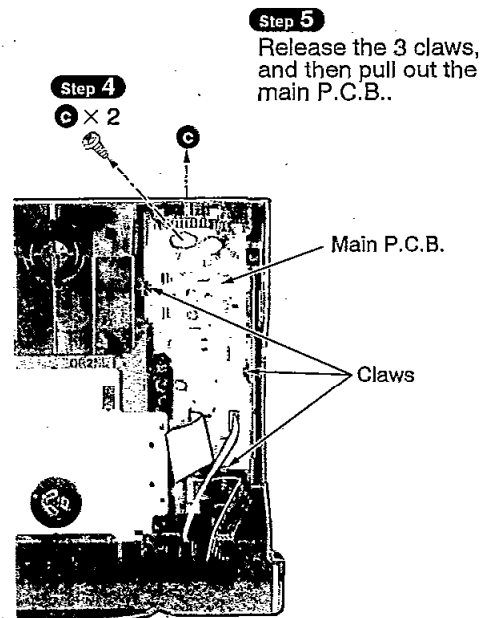
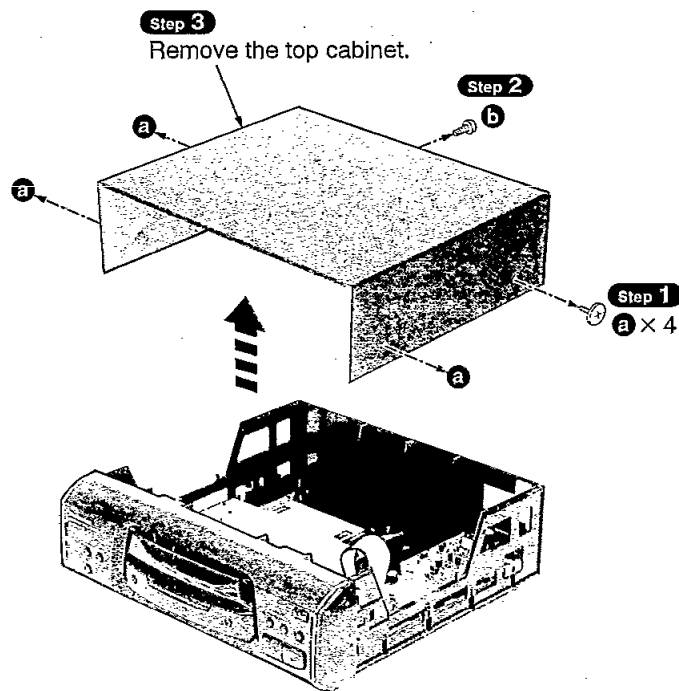

• Check the main P.C.B. as shown below.

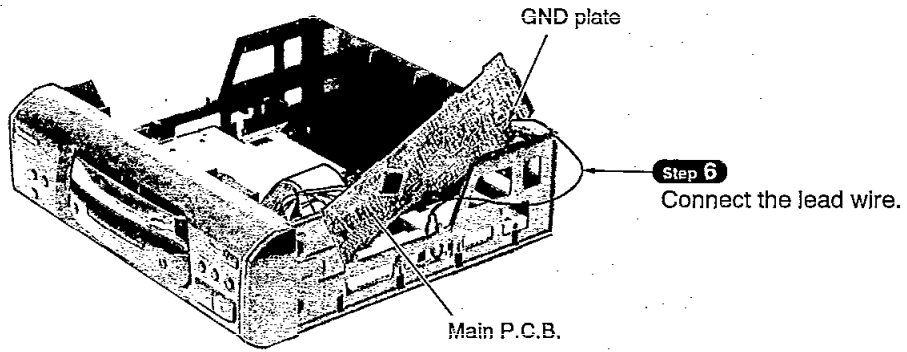

2. Checking for the servo P.C.B. and operation P.C.B.

• Follow the item 1 (**Step 1** ~ **Step 3**) in checking procedures for each P.C.B. on page 5.

Step 2

Release the 2 claws, and then remove the tray ornament.

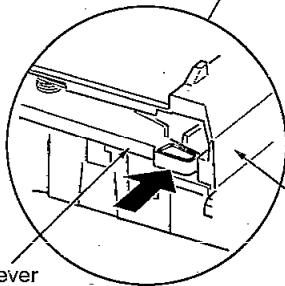
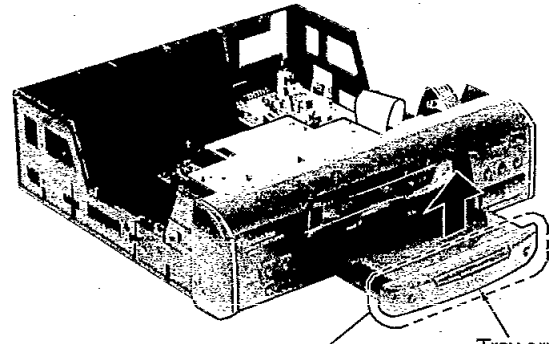
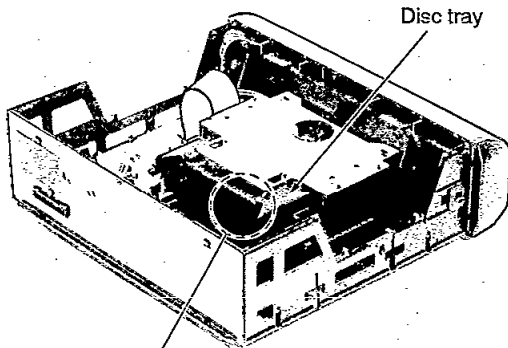

Step 1

Push the lever and extrude the disc tray forward.

Disc tray

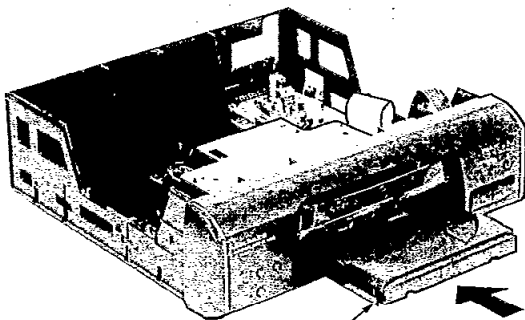
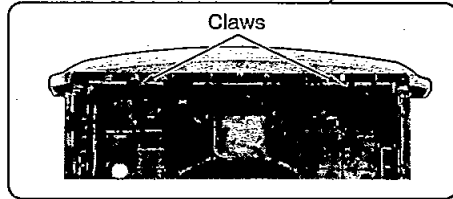

Step 3

Push the disc tray.

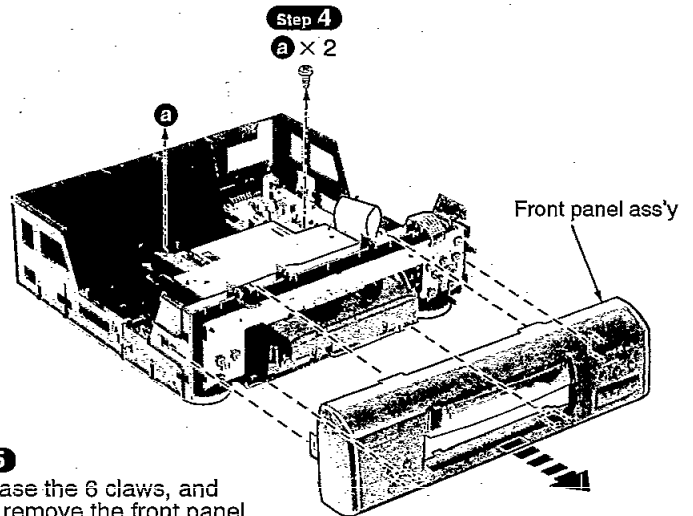

Step 5

Release the 6 claws, and then remove the front panel ass'y.

- Check the servo P.C.B. and operation P.C.B. as shown below.

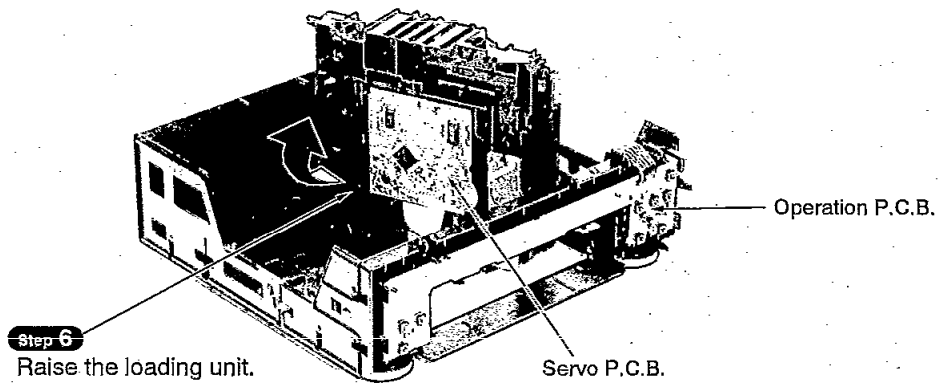

Main Component Replacement Procedures

1. Replacement for the traverse deck ass'y

- Follow the Item 1 (**Step 1** ~ **Step 3**) in checking procedures for each P.C.B. on page 5.
- Follow the Item 2 (**Step 1** ~ **Step 4**) in checking procedures for each P.C.B. on page 6.

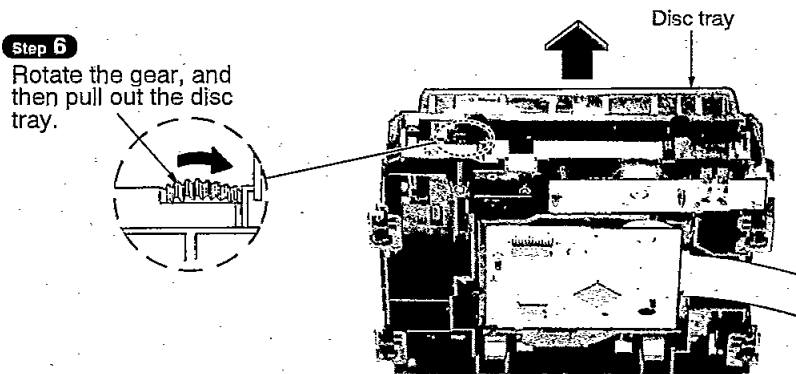
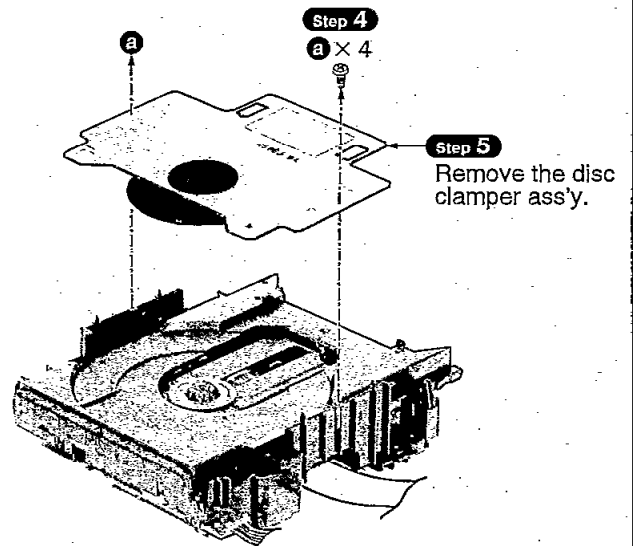
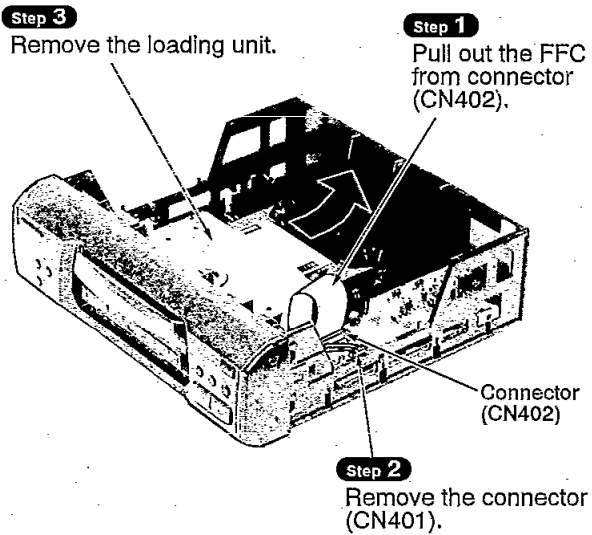

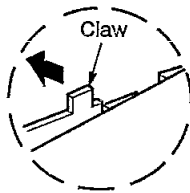

Step 8
Pull out the disc tray.

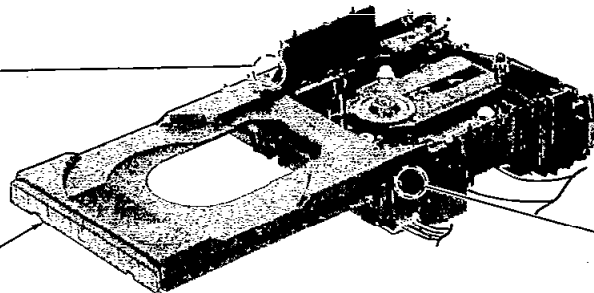

Step 7
Release the 2 claws.

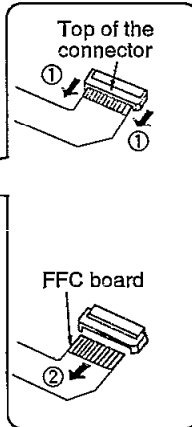
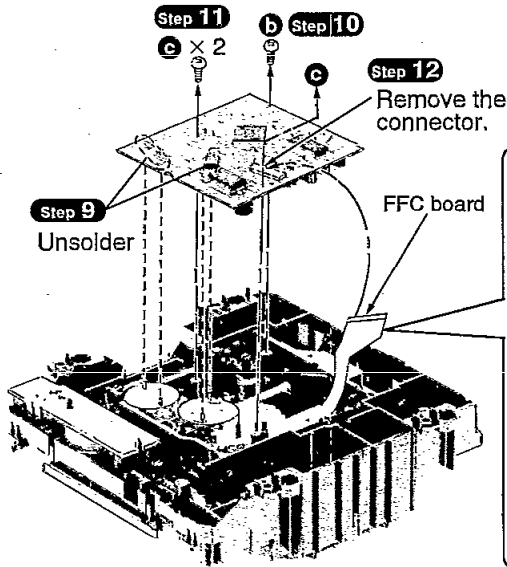
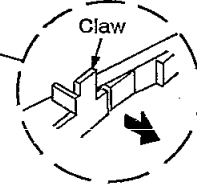

Caution:
Insert a short pin into the traverse unit FFC board.
(Refer to "Handling Precautions for Traverse Deck" on page 2.)

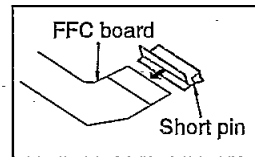

Step 13

1. Widen the boss using a regular screwdriver.
2. Pull out the pin in the direction of the arrow.

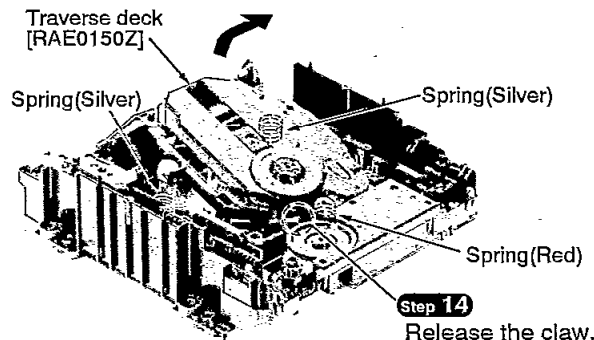
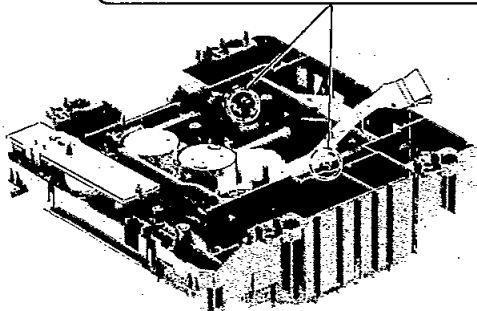
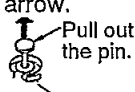
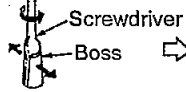

Step 14
Release the claw.

NOTE
Be careful not to lose the 3 springs because those will also be removed on removal of the traverse unit ass'y.

Installation of the servo P.C.B. after replacement

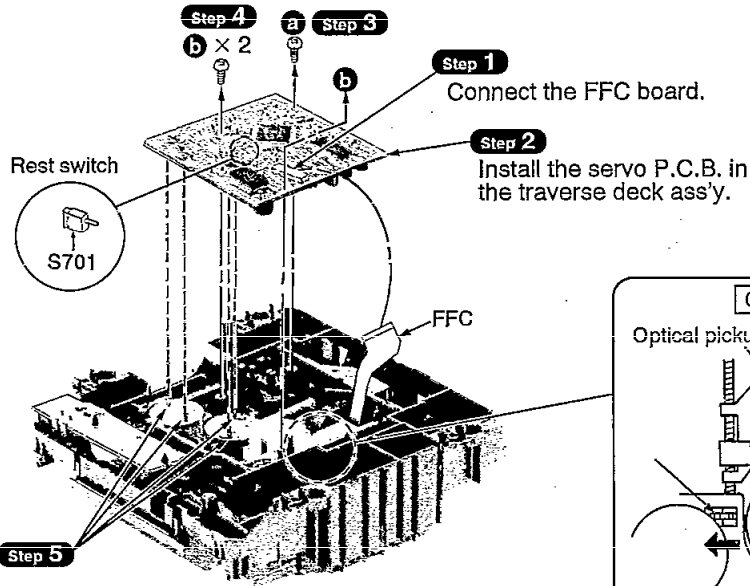

NOTE
 Before installing the servo P.C.B., move the optical pickup toward the outer edge from the mark "◀".
 [Otherwise, the rest detect switch (S701) mounted on the servo P.C.B. may be damaged.]

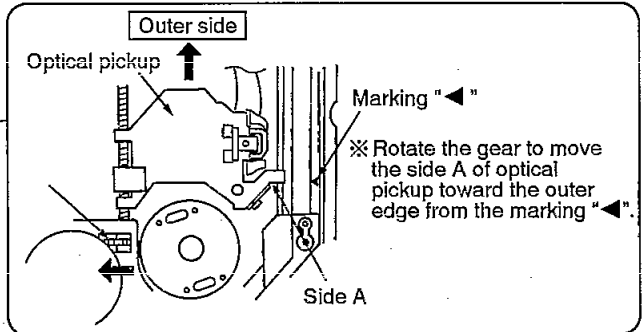

Installation of the disc tray after replacement

Step 2
 Operate the lever, and then locate the traverse deck to "UP" position.

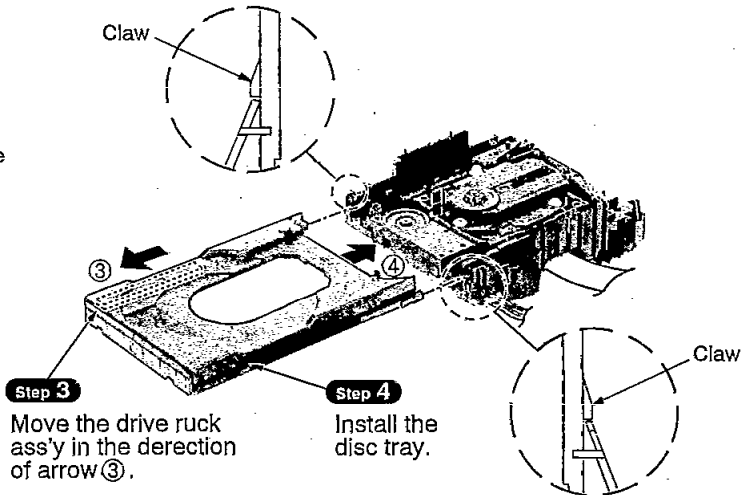
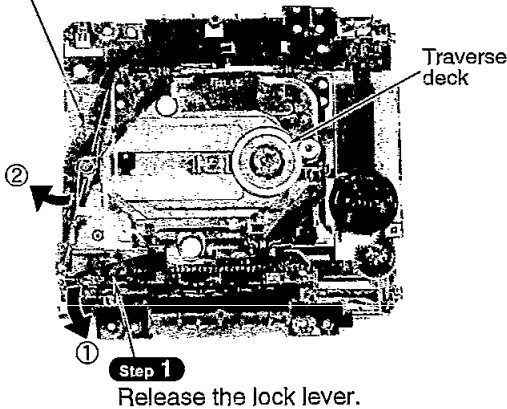

Step 5
 Hold the disc tray and slide the drive ruck ass'y.

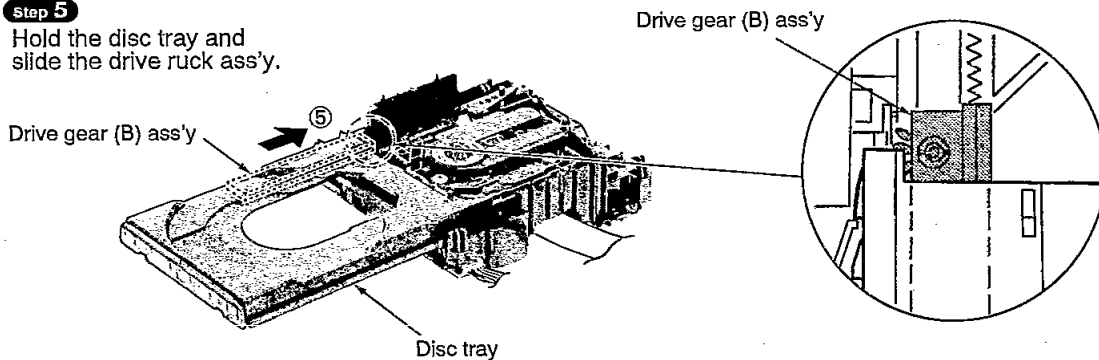

Step 6

Operate the lever, and then locate the traverse deck to "DOWN" position.

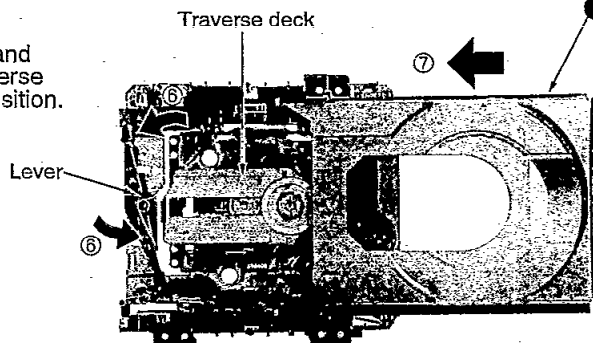

Step 7

Press the disc tray.

2. Replacement for the belt, loading motor ass'y and loading switch

- Follow the item 1 (**Step 1** ~ **Step 3**) in checking procedures for each P.C.B. on page 5.
- Follow the item 2 (**Step 1** ~ **Step 4**) in checking procedures for each P.C.B. on page 6.
- Follow the item 1 (**Step 1** ~ **Step 8**) in main component procedures on pages 7 and 8.

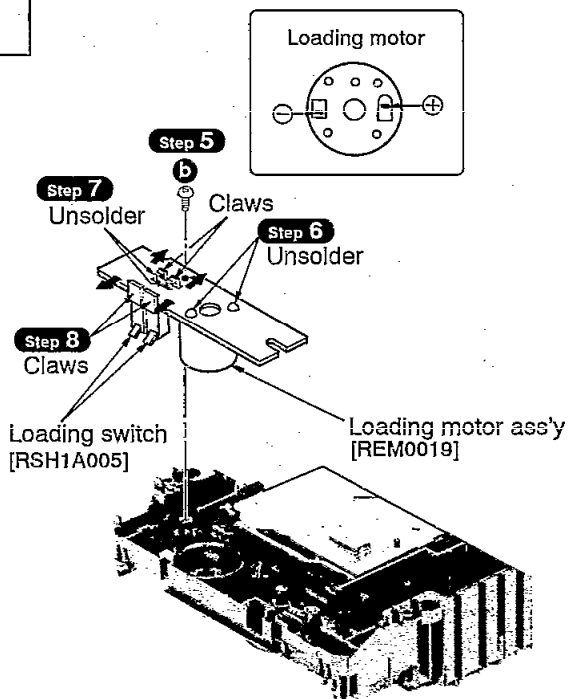
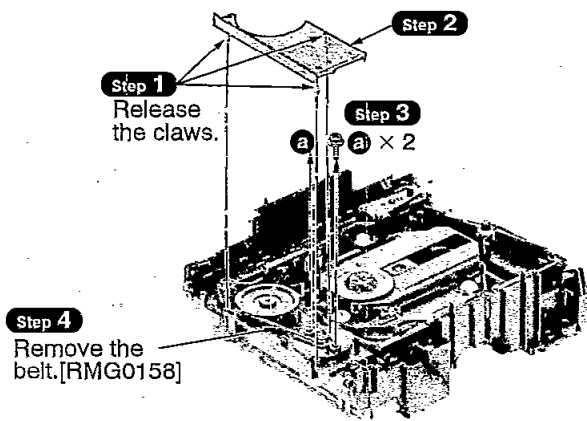

Automatic Adjustment Results Display Function

Self-Check Function

- The system control IC is incorporated only in the tuner/amplifier (SA-EH50), but can be directly connected to any other system module to carry out diagnostic checks. As each system module is checked, a result code is indicated on the tuner's display panel.

For Europe and Russia: SC-EH50 (SL-EH50/SA-EH50/SH-EH50/RS-EH60/SB-EH60)

For Others: SC-EH50 (SL-EH50/SA-EH50/SH-EH50/RS-EH60/SB-EH50/SB-PC60/SB-PT60)

- This unit is able to utilize the display panel of the tuner/amplifier (SA-EH50) to indicate the results of automatic adjustment of the servo-circuit (tracking, focus, offset, etc.) as error codes. The error code display indicates the location of failures from automatic adjustment circuit.

The following procedure displays the error codes from the self-diagnostic function.

Procedure for displaying automatic adjustment codes

- Turn on the power supply switch.
- Push the OPEN/CLOSE button to open the disc tray and then load the test disc (SZZP1054C).
- Push the OPEN/CLOSE button again to close the disc tray.
- Push the REPEAT button for two seconds. With the REPEAT button held down, push the STOP button for two seconds.
- After automatic adjustment, the code display indicates the location of failures in the servo circuit.

Notes: If "E-00" is displayed as an error code, this means no error was found.

- Next, push the FWD SKIP button and fault diagnoses of the following switches will be displayed:

"H-15": disc tray open detection switch is faulty.









"H-16": disc tray close detection switch is faulty.

"F-15": rest switch is faulty.

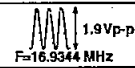
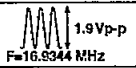
- Take out the test disc and turn off the power, which terminates the automatic adjustment results mode.

Troubleshooting using the automatic adjustment code

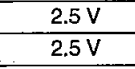
Notes: Check the disc and laser-detector lens for damage, contamination or stains.

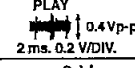
FL error code display	Symptom	Probable cause	Signal to check		Normal voltage and waveform values	
			Location	Signal name	PLAY	STOP
E-01	Focus and tracking offset adjustments not completed in specified time period.	①Clocks X1 and X2, power supply VDD, and reset (/RST), all on IC702. ②MDATA, MCLK, MLD, and SENSE signals to/from mechanism controller.	IC702 ⑧ pin	MDATA		0 V
			IC702 ⑦ pin	MCLK		4.8 V
			IC702 ⑨ pin	MLD	0 V	0 V
			IC702 ⑩ pin	SENSE	0 V	0 V
			IC702 ⑱ pin	/RST	4.9 V	4.9 V
			IC702 ⑤⑧ pin	X1		
IC702 ⑤⑨ pin	X2					
E-02 E-03 E-05 E-06 E-07 E-09 E-0A E-0B E-0D E-0E E-0F	Disc play unstable	①Scratches or contaminants on disc surface ②Focus and Tracking servo circuits (check waveforms, voltages, and part values.) ③Spindle driver circuit ④Optical pickup	IC702 ⑩② pin	FE		2.5 V
IC702 ⑩③ pin			TE		2.5 V	
IC702 ⑩④ pin			FOD	2.5 V	2.5 V	
IC702 ⑩⑦ pin			TRD	2.5 V	2.5 V	
IC702 ⑩⑥ pin			KICK	2.5 V	2.5 V	
IC702 ⑩① pin			/FLOCK	0 V	4.9 V	
IC702 ⑩⑧ pin			/RF DET	0 V	4.9 V	
TJ701			RF		2.4 V	
IC702 ⑩⑦ pin			STAT	4.9 V	0 V	
E-04 E-08 E-0C			Focus or Tracking gain adjustment not completed in specified time period.	①Scratches or contaminants on disc surface ②Focus servo circuit (check waveforms, voltages, and part values.) ③Optical pickup	IC702 ⑩② pin	FE
IC702 ⑩③ pin	TE				2.5 V	
IC702 ⑩⑥ pin	OFT	0 V			0 V	
IC702 ⑩② pin	/TLOCK	0 V			0 V	

■ To Supply Power Source

Cautions:

- It is very dangerous to look at or touch the laser beam. (Laser radiation is invisible.)
With the unit turned "on", laser radiation is emitted from the pickup lens.
- Avoid exposure to the laser beam, especially when performing adjustments.

This unit SL-EH50 is designed to operate on power supplied from the Tuner/Amplifier (SA-EH50) through the Cassette Deck (RS-EH60).

When connecting the unit to other system components, do not connect to the Tuner/Amplifier (SA-EH50) directly. Be sure to connect this unit through the Cassette Deck (RS-EH60).

When operating the unit (SL-EH50) alone for testing and servicing, without having power supplied from the Tuner/Amplifier SA-EH50 and the Cassette Deck (RS-EH60), use the following method.

Power Supply to This Unit alone

Apply 10V DC power to the section between L401 **DC10V** and E401 **GND**. (Shown in Fig. 1)

To Perform Specific Operations

Simultaneously shorting the section between jumper J6 and each resistor (R431, R432, R433 and R434) allows the following operations to be carried out:

- R431 Play and stop
- R432 Forward skip
- R433 Disc tray open and close
- R434 Reverse skip

To Check Signals

Connect the oscilloscope or the speaker with built-in amplifier to the section between LINE OUT (Lch) of the resistor R455 and the E401 **GND** as well as the section between LINE OUT (Rch) of the resistor R456 and the E401 **GND** and check if the signals are outputting from this unit. (Shown in Fig. 1)

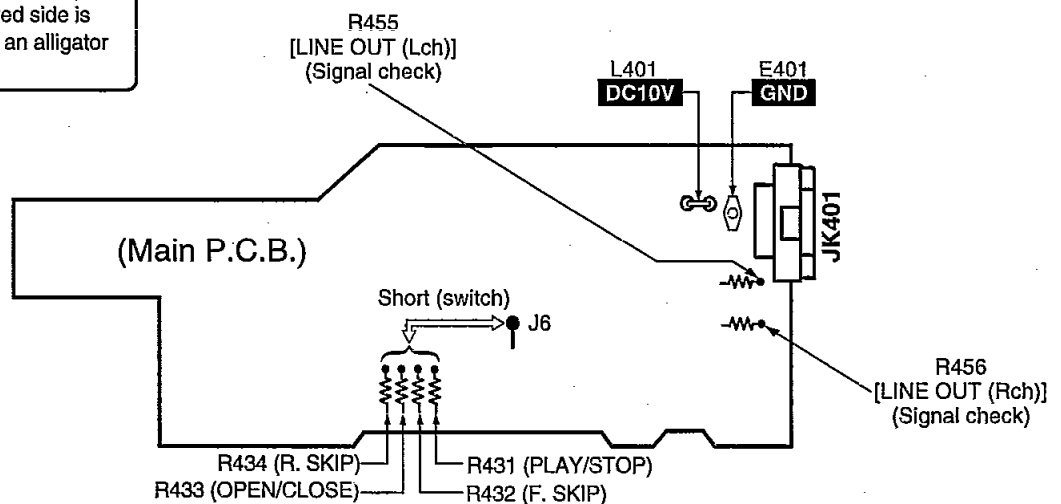
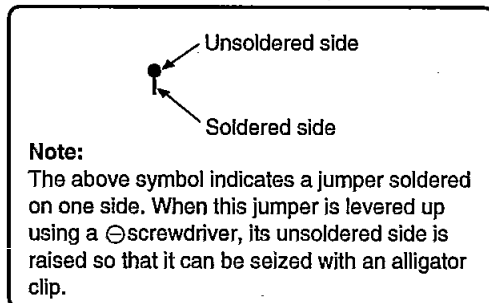

Fig. 1

■ Schematic Diagram

	Page
A SERVO CIRCUIT	14, 15
B LOADING MOTOR CIRCUIT	16
C OPERATION CIRCUIT	16
D MAIN CIRCUIT	16, 17

- This schematic diagram may be modified at any time with the development of new technology.

Notes:

- **S701** : Rest switch
- **S790** : Disc tray open detect switch
- **S791** : Disc tray close detect switch
- **S801** : Disc tray open/close switch (\blacktriangle OPEN/CLOSE)
- **S802** : Pause switch (\blacksquare)
- **S803** : F. Skip/Search switch ($\blacktriangleright/\blacktriangleright$)
- **S804** : Play switch (\blacktriangleright)
- **S805** : Stop switch (\blacksquare)
- **S806** : R. Skip/Search switch ($\blacktriangleleft/\blacktriangleleft$)
- **S807** : Random play switch (RANDOM)
- **S809** : AI edit switch (AI EDIT)
- **S810** : Repeat switch (REPEAT)

- Indicated voltage values are the standard values for the unit measured by the DC electronic circuit tester (high-impedance) with the chassis taken as standard. Therefore, there may exist some errors in the voltage values, depending on the internal impedance of the DC circuit tester.

▶▶▶▶ mark : CD STOP
 () : CD PLAY [1kHz, L + R, 0 dB]



- Important safety notice:

Components identified by \blacktriangle mark have special characteristics important for safety.
 Furthermore, special parts which have purposes of fire-retardant (resistors), high-quality sound (capacitors), low-noise (resistors), etc. are used. When replacing any of components, be sure to use only manufacturer's specified parts shown in the parts list.

- **Caution!**

IC and LSI are sensitive to static electricity.
 Secondary trouble can be prevented by taking care during repair.
 Cover the parts boxes made of plastics with aluminum foil.
 Ground the soldering iron.
 Put a conductive mat on the work table.
 Do not touch the legs of IC or LSI with the fingers directly.

- **Voltage and signal line**

 : Positive voltage line
 : CD signal line

A SERVO CIRCUIT (P.C.Board: on page 18)

Δ OPTICAL PICKUP CIRCUIT

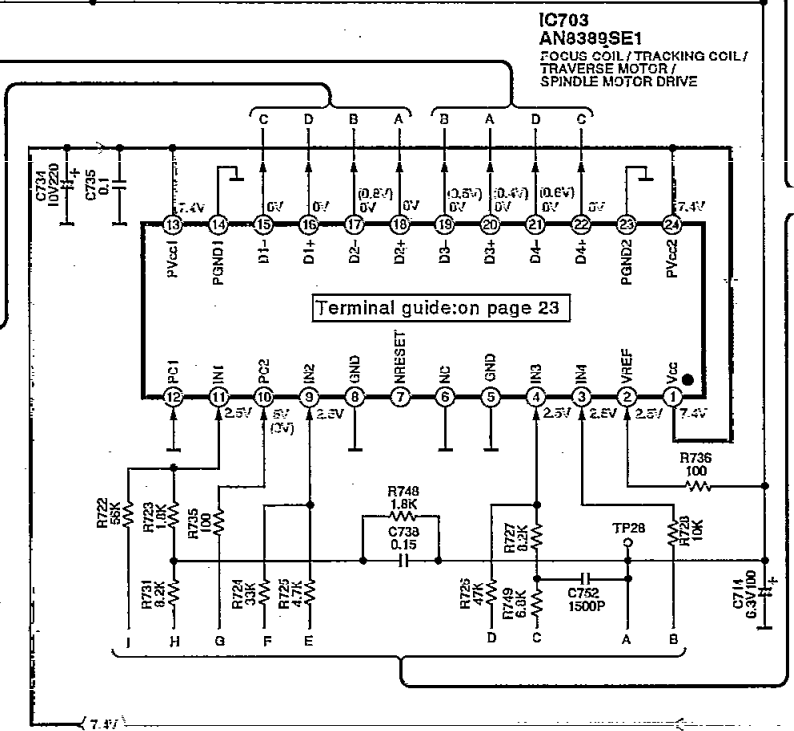
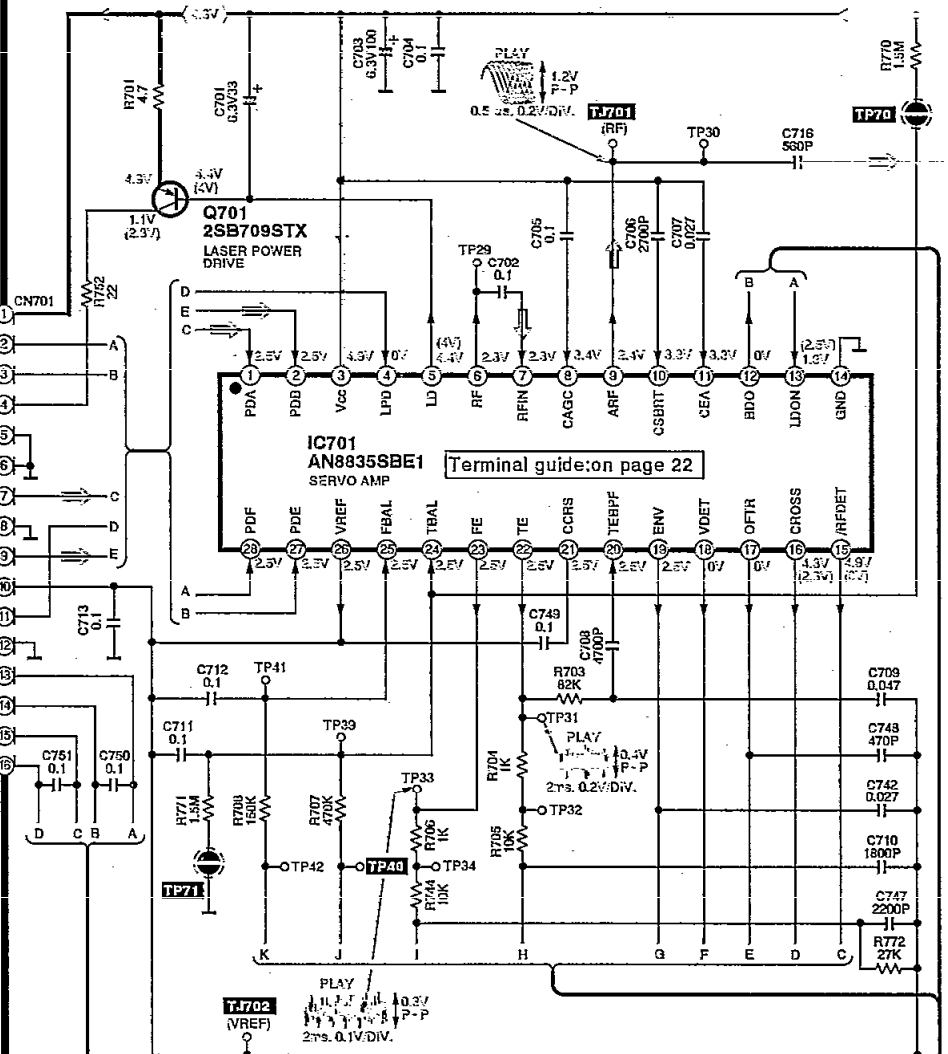
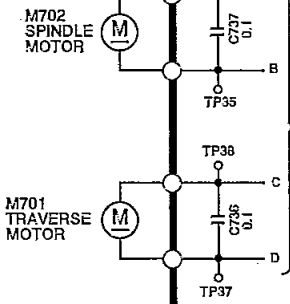
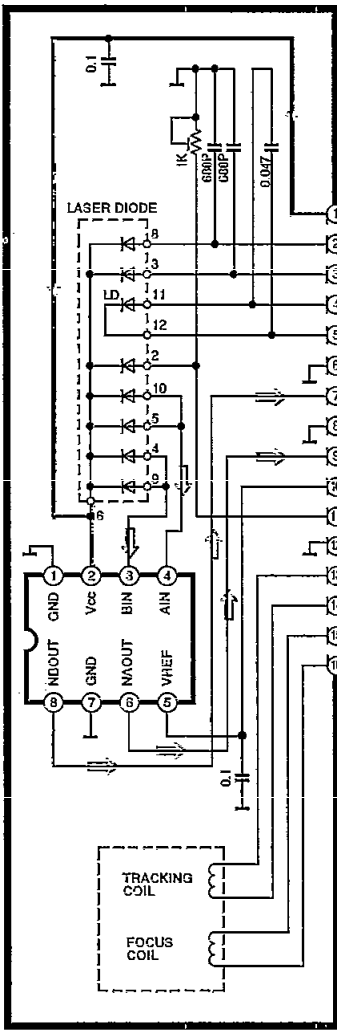

— : Positive voltage Line

⇨ : CD signal Line

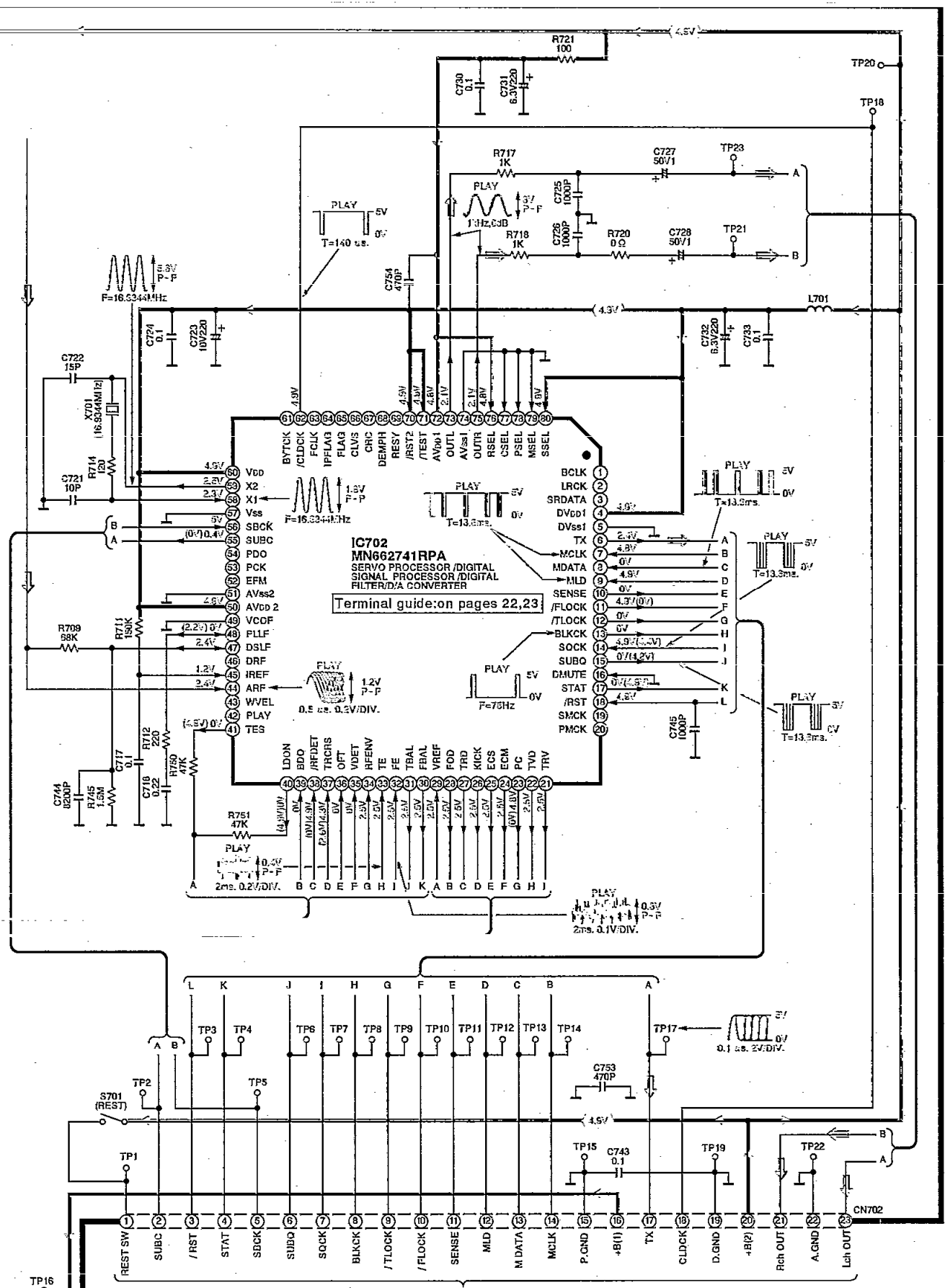

To MAIN CIRCUIT (CN402) on page 17

B LOADING MOTOR CIRCUIT (P.C.Board: on page 18)

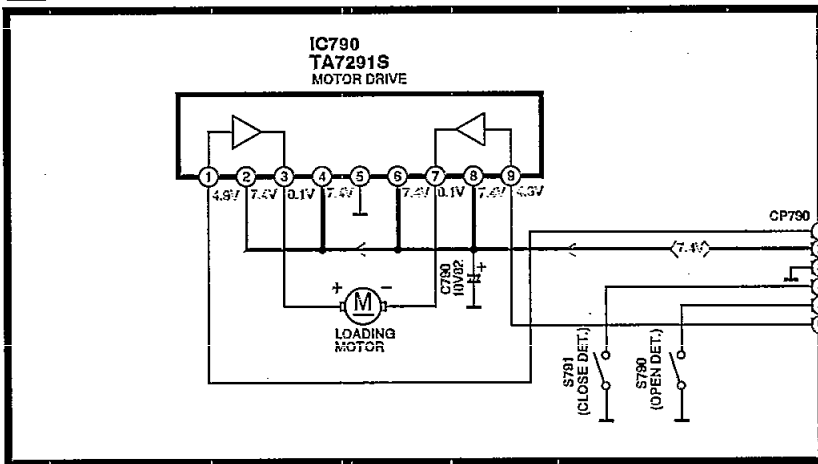

C OPERATION CIRCUIT (P.C.Board: on page 19)

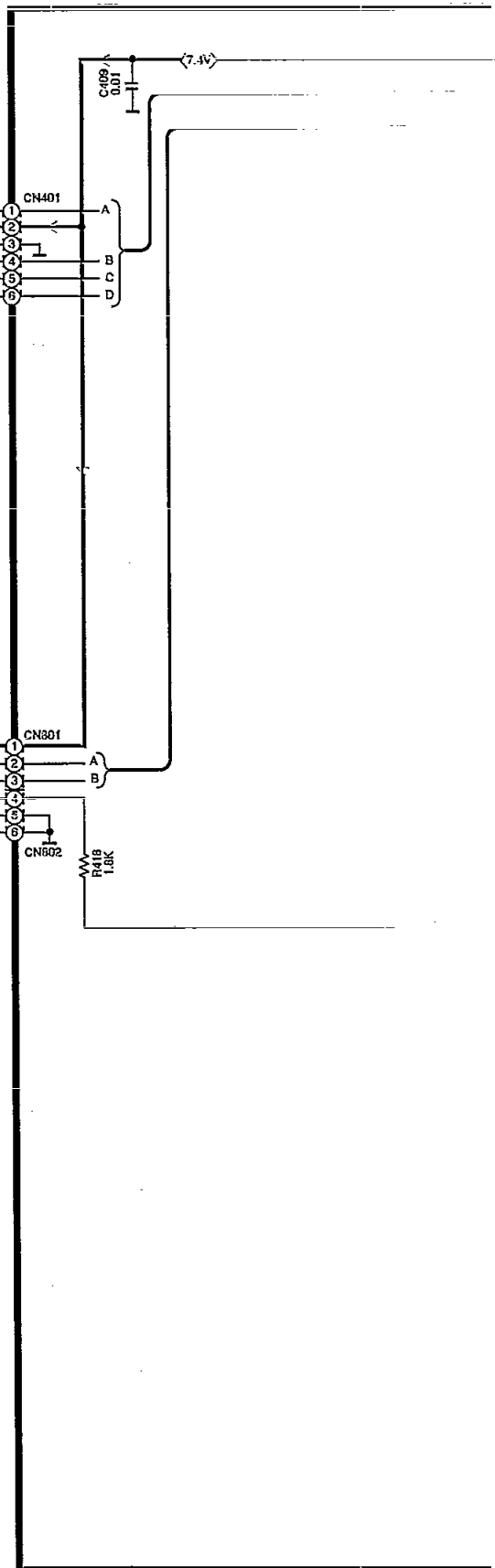
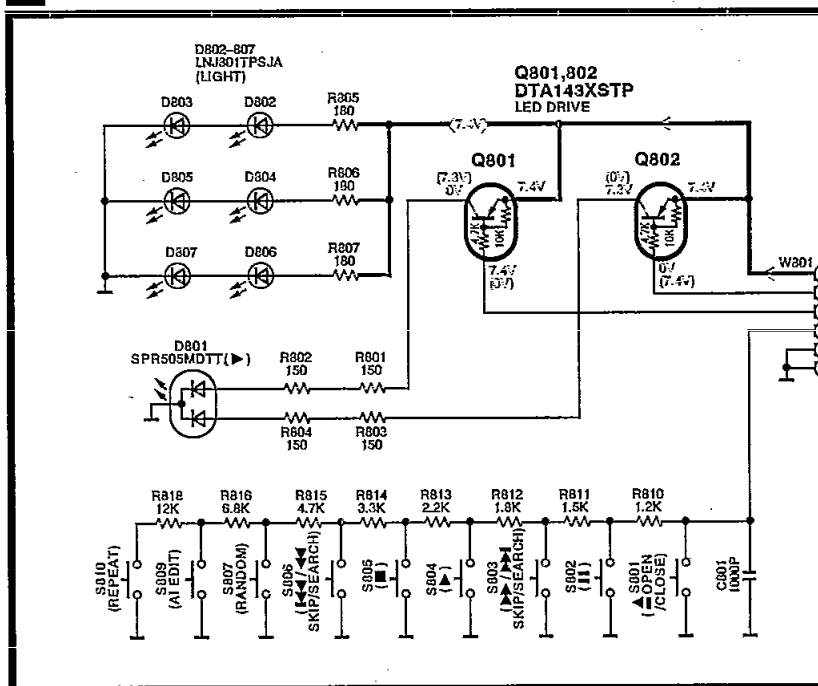

→ : Positive voltage Line

⇨ : CD signal Line

D MAIN CIRCUIT (P.C.Board: on page 19)

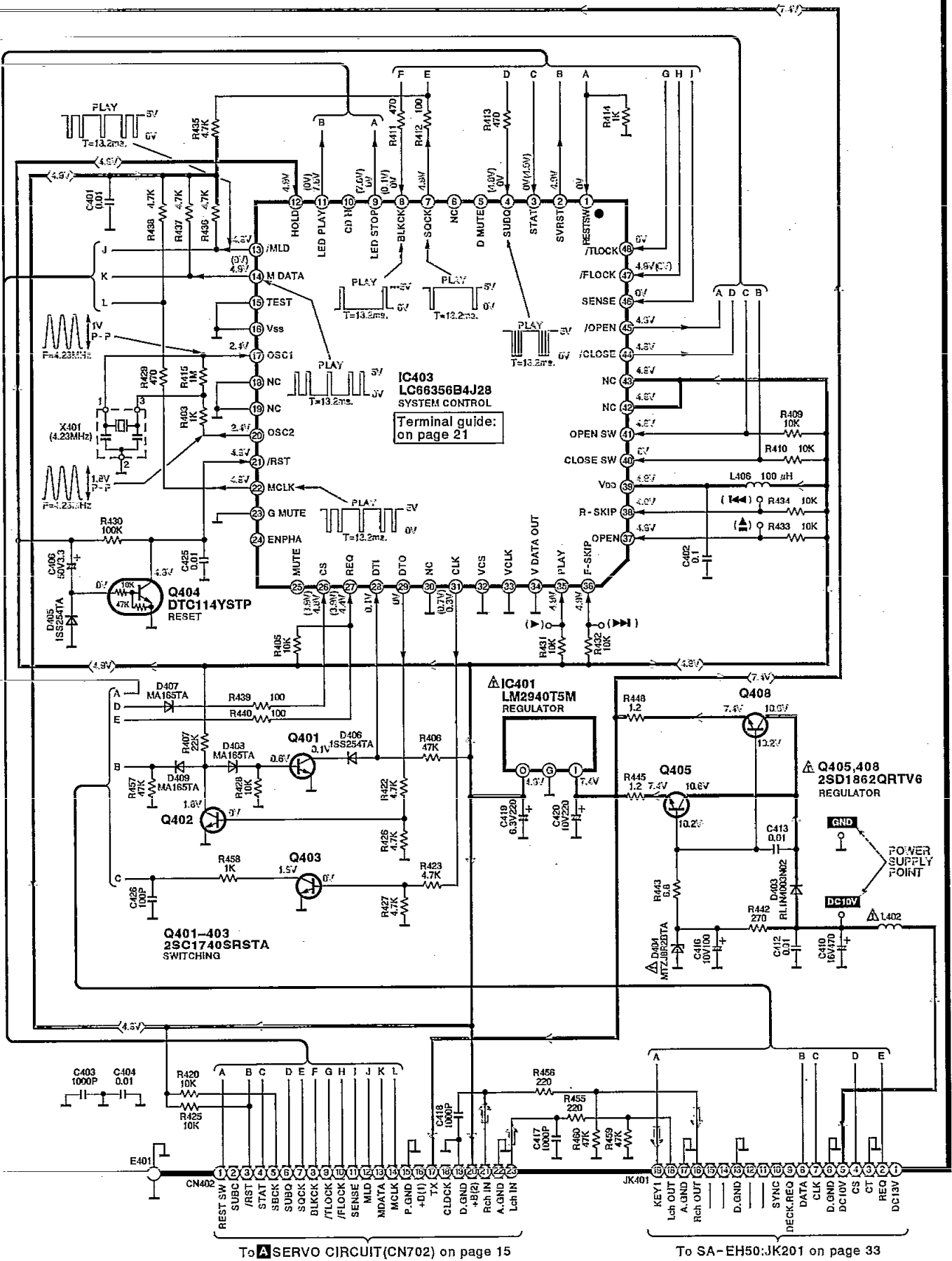

■ Type Illustration of IC's, Transistors and Diodes

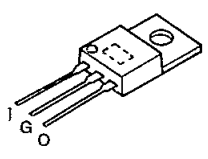
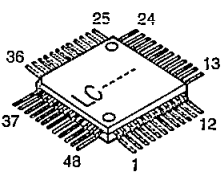
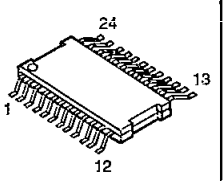
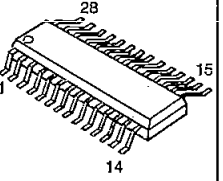
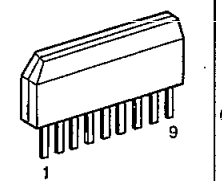
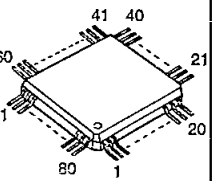
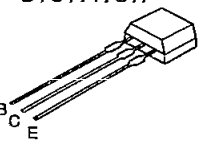
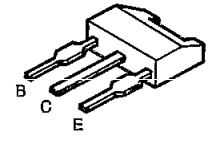
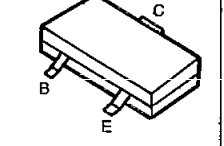
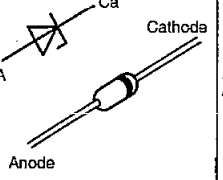
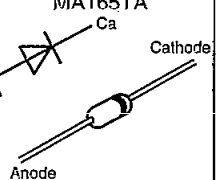
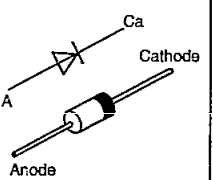
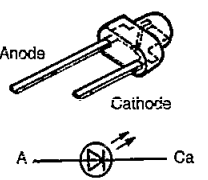
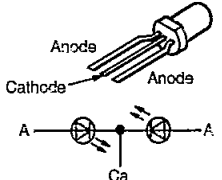
<p>LM2940T5M</p> 	<p>LC66356B4J28</p> 	<p>AN8389SE1</p> 	<p>AN8835SBE1</p> 	<p>TA7291S</p> 	<p>MN662741RPA</p> 
<p>2SC1740SRSTA DTA143XSTP DTC114YSTP</p> 	<p>2SD1862QRTV6</p> 	<p>2SB709STX</p> 	<p>MTZJ8R2BTA</p> 	<p>1SS254TA MA165TA</p> 	<p>RL1N4003N02</p> 
<p>LNJ801TPSJA</p> 	<p>SPR505MDTT</p> 				

■ Wiring Connection Diagram

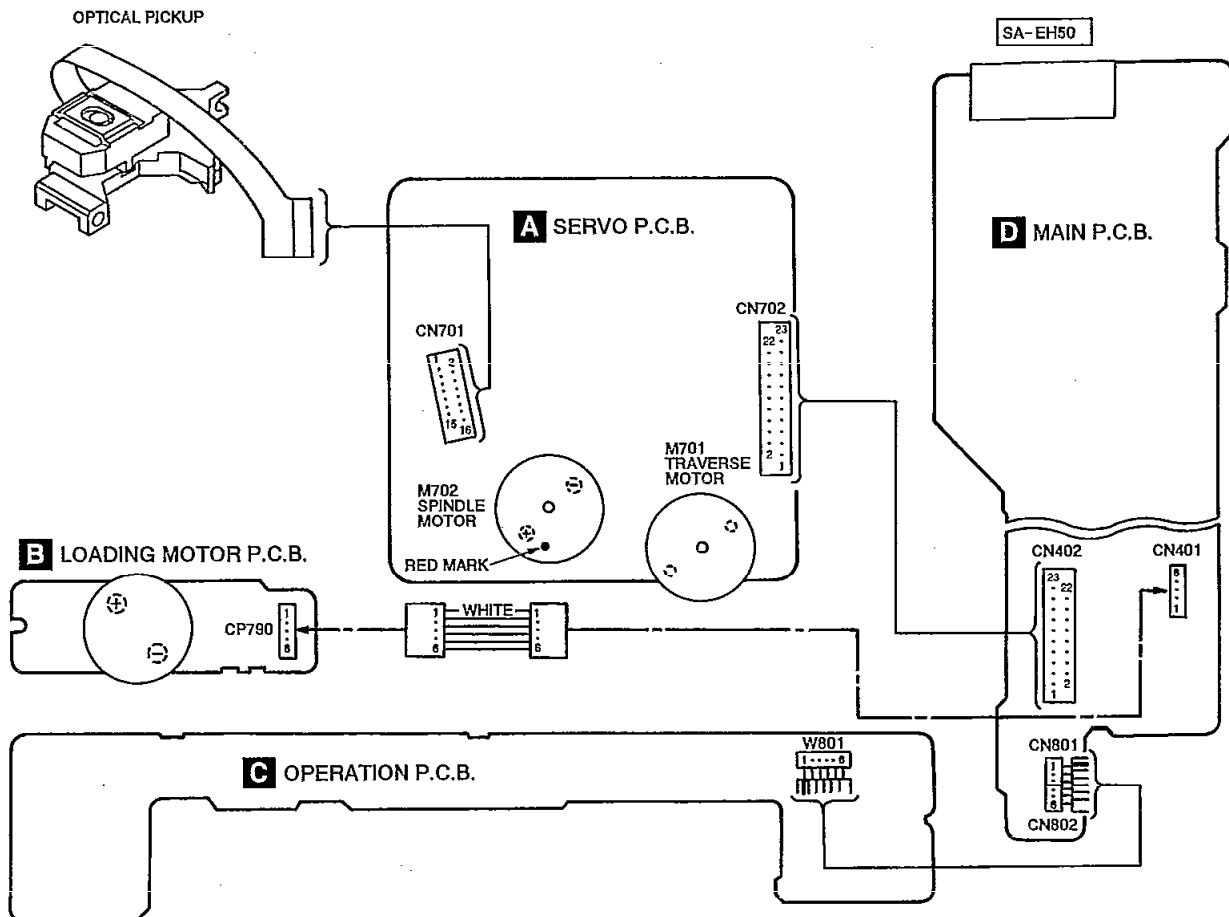

Terminal Function of IC's

• IC403 (LC66356B4J28): System control

Pin No.	Terminal Name	I/O	Function
1	REST SW	I	Innermost track sense switch (S701: rest switch) signal input
2	SVRST	O	Servo IC (IC702) reset signal output
3	STAT	I	Status signal input
4	SUBQ	I	Sub-code Q data input
5	DMUTE	—	Not used
6	NC	—	Not used
7	SQCK	O	Sub-code Q data clock output
8	BLKCK	I	Sub-code block clock input
9	LED STOP	O	LED (D801) drive signal output
10	CD H	—	Not used
11	LED PLAY	O	LED (D801) drive signal output
12	HOLD	—	Not used (Connected to VDD)
13	/MLD	O	IC702 command load signal output
14	MDATA	O	IC702 command data output
15	TEST	—	Test terminal (Not used) (Connected to GND)
16	VSS	—	GND terminal
17	OSC1	I	Clock signal input
18	NC	—	Not used (Connected to GND)
19	NC	—	Not used (Connected to GND)
20	OSC2	O	Clock signal output
21	/RST	I	Reset signal input
22	MCLK	O	IC702 command clock output
23	G MUTE	—	Not used (Connected to GND)
24	ENPHA	—	Not used
25	MUTE	—	Not used
26	CS	I	Serial data communication starting signal input
27	REQ	I	Command request data input
28	DTI	I	Serial data input
29	DTO	O	Serial data output
30	NC	—	Not used (Connected to GND)
31	CLK	O	Serial clock output
32	VCS	—	Not used (Connected to GND)

Pin No.	Terminal Name	I/O	Function
33	VCLK	—	Not used (Connected to GND)
34	V DATA OUT	—	Not used (Connected to GND)
35	PLAY	I	Play/stop switch signal input
36	F-SKIP	I	F. Skip switch signal input
37	OPEN	I	Disc tray open/close switch signal input
38	R-SKIP	I	R. Skip switch signal input
39	VDD	—	Power supply (+5V)
40	CLOSE SW	I	Disc tray "close" detection switch signal input
41	OPEN SW	I	Disc tray "open" detection switch signal input
42	NC	—	Not used
43	NC	—	Not used
44	/CLOSE	O	Disc tray "close" command signal output
45	/OPEN	O	Disc tray "open" command signal output
46	SENCE	I	IC702 sense signal input
47	/FLOCK	I	IC702 focus lock signal input
48	/TLOCK	I	IC702 tracking signal input

● IC701 (AN8835SBE1): Servo Amp.

Pin No.	Terminal Name	I/O	Function
1	PDA	I	Focus (A-ch) signal input terminal
2	PDB	I	Focus (B-ch) signal input terminal
3	VCC	I	Power supply terminal
4	LPD	I	Laser PD signal input
5	LD	O	Laser power auto control signal output
6	RF	O	RF amp. terminal
7	RF IN	I	AGC input terminal
8	CAGC	I	AGC detection capacitor input
9	ARF	O	RF signal output
10	CSBRT	I	OFTR capacitor connection terminal
11	CEA	I	HPF-AMP capacitor connection terminal
12	BDO	O	Dropout detection control signal output
13	LDON	I	LD APC ON/OFF ("H": ON, "L": OFF)
14	GND	—	GND terminal
15	/RFDET	O	RF detection signal output ("L": det.)
16	CROSS	O	Tracking error zero cross output
17	OFTR	O	Off track detection signal output ("H": det.)
18	VDET	O	Vibration detection signal output ("H": det.)
19	ENV	O	Envelope output terminal
20	TEBPF	I	Vibration detection signal input ("H": det.)
21	CCRS	I	CROSS capacitor connection terminal
22	TE	O	Tracking error signal output
23	FE	O	Focus error signal output
24	TBAL	I	Tracking balance adjustment signal input
25	FBAL	I	Focus balance adjustment signal input
26	VREF	O	Reference voltage output
27	PDE	I	Tracking signal (E-ch) input terminal
28	PDF	I	Tracking signal (F-ch) input terminal

● IC702 (MN662741RPA): Servo Processor, Digital Signal Processor, Digital Filter, D/A Converter

Pin No.	Terminal Name	I/O	Function
1	BCLK	O	Bit clock output for serial data
2	LRCK	O	L/R clock signal output
3	SRDATA	O	Serial data output
4	DVDD1	—	Power supply input (for digital circuit)
5	DVSS1	—	GND (for digital circuit)
6	TX	O	Digital audio interface signal output
7	MCLK	I	Microprocessor command clock signal input (Latches data at first transition)
8	MDATA	I	Microprocessor command data signal input
9	MLD	I	Microprocessor command load signal input
10	SENSE	O	Sense signal output (OFT, FESL, MAGEND, NAJEND, POSAD, SFG) (Not used, open)
11	/FLOCK	O	Focus servo feeding signal output ("L": Feed)
12	/TLOCK	O	Tracking servo feeding signal output ("L": Feed) (Not used, open)
13	BLKCK	O	Sub-code block clock signal output (fBLKCK = 75 Hz during normal playback)
14	SQCK	I	External clock signal input for sub-code Q resistor
15	SUBQ	O	Sub-code Q code output
16	DMUTE	I	Muting input ("H": Mute)
17	STAT	O	Status signal output (CRC, CUE, CLVS, TTSTVP, FCLV, SQCK)
18	/RST	I	Reset signal input
19	SMCK	—	1/2-divided clock signal of crystal oscillating at MSEL = "H" (fSMCK = 8.4672 MHz) 1/4-divided clock signal of crystal oscillating at MSEL = "L" (fSMCK = 4.2336 MHz) (Not used, open)
20	PMCK	—	1/192-divided clock signal of crystal oscillating (fPMCK = 88.2 kHz) (Not used, open)
21	TRV	O	Traverse forced feed output
22	TVD	O	Traverse drive output
23	PC	O	Spindle motor ON signal output ("L": ON)
24	ECM	O	Spindle motor drive signal output (forced mode output)
25	ECS	O	Spindle motor drive signal output (servo error signal output)
26	KICK	O	Kick pulse output
27	TRD	O	Tracking drive output
28	FOD	O	Focus drive output
29	VREF	I	D/A (drive) output (TVD, ECS, TRD, FOD, FBAL, TBAL) reference voltage input
30	FBAL	O	Focus balance adjustment output
31	TBAL	O	Tracking balance adjustment output
32	FE	I	Focus error signal input (analog input)
33	TE	I	Tracking error signal input (analog input)
34	RFENV	I	RF envelope signal input
35	VDET	I	Vibration detection signal input ("H": detection)

Pin No.	Terminal Name	I/O	Function
36	OFT	I	Off-track signal input ("H": off track)
37	TRCRS	I	Track cross signal input
38	/RFDET	I	RF detection signal input ("L": detection)
39	BDO	I	Dropout signal input ("H": Dropout)
40	LDON	O	Laser on signal output ("H": ON)
41	TES	O	Tracking error shunt signal output ("H": shunt)
42	PLAY	O	Play signal out ("H": PLAY) (Not used, open)
43	WVEL	O	Double speed status signal output ("H": Double speed) (Not used, open)
44	ARF	I	RF signal input
45	IREF	I	Reference current input
46	DRF	—	DSL bias (Not used, open)
47	DSLIF	I/O	DSL loop filter
48	PLLIF	I/O	PLL loop filter
49	VCOF	I/O	VCO loop filter
50	AVDD2	—	Power supply input (for analog circuit)
51	AVSS2	—	GND (for analog circuit)
52	EFM	—	EFM signal output (Not used, open)
53	PCK	—	PLL extraction clock output (fPCK= 4.321 MHz during normal playback) (Not used, open)
54	PDO	—	Phase comparison signal of EFM and PCK signals (Not used, open)
55	SUBC	O	Sub-code serial data output
56	SBCK	I	Clock input for sub-code serial data
57	VSS	—	GND
58	X1	I	Crystal oscillating circuit input (f = 16.9344 MHz)
59	X2	O	Crystal oscillating circuit output (f = 16.9344 MHz)
60	VDD	—	Power supply input (for oscillating circuit)
61	BYTCK	—	Byte clock output (Not used, open)
62	/CLDCK	O	Sub-code frame clock signal output (fCLDCK = 7.35 kHz during normal playback)
63	FCLK	—	Crystal frame clock signal output (fFCLK = 7.35 kHz, double = 14.7 kHz) (Not used, open)
64	IPFLAG	O	Interpolation flag output ("H": Interpolation)
65	FLAG	O	Flag output (Not used, open)
66	CLVS	O	Spindle servo phase synchronizing signal output ("H": CLV, "L": rough servo) (Not used, open)
67	CRC	O	Sub-code CRC checked output ("H": OK, "L": NG) (Not used, open)
68	DEMPH	O	De-emphasis ON signal output ("H": ON) (Not used, open)
69	RESY	—	Frame re-synchronizing signal output (Not used, open)
70	/RST2	I	Reset input through MASH circuit ("L": Reset)
71	/TEST	I	Test input

Pin No.	Terminal Name	I/O	Function
72	AVDD1	—	Power supply input (for analog circuit)
73	OUTL	O	Left channel audio signal output
74	AVSS1	—	GND
75	OUTR	O	Right channel audio signal output
76	RSEL	I	RF signal polarity assignment input (at "H" level: RSEL = "H") (at "L" level: RSEL = "L")
77	CSEL	I	Crystal oscillating frequency designation input ("L": 16.9344 MHz, "H": 33.8688 MHz)
78	PSEL	I	Audio serial data signal input
79	MSEL	I	Audio L/R clock signal input
80	SSEL	I	Audio Bit clock signal input

• IC703 (AN8389SE1): Focus/Tracking Coil Driver
Traverse/Spindle Motor Driver

Pin No.	Terminal Name	I/O	Function
1	VCC	—	Power supply
2	VREF	I	VREF input
3	IN4	I	Focus driver (4) input
4	IN3	I	Tracking driver (3) input
5	GND	—	Ground connection
6	NC	—	Ground connection
7	NRESET	—	Reset input (Not used, open)
8	GND	—	Ground connection
9	IN2	I	Spindle motor driver (2) input
10	PC2	I	PC2 (power cut) input
11	IN1	I	Traverse motor driver (1) input
12	PC1	I	PC1 (power cut) input
13	PVCC1	—	Power supply (1) for driver
14	PGND1	—	Ground connection (1) for driver
15	D1-	O	Traverse motor driver (1) reverse-action output
16	D1+	O	Traverse motor driver (1) forward-action output
17	D2-	O	Spindle motor driver (2) reverse-action output
18	D2+	O	Spindle motor driver (2) forward-action output
19	D3-	O	Tracking actuator (3) reverse-action output
20	D3+	O	Tracking actuator (3) forward-action output
21	D4-	O	Focus actuator (4) reverse-action output
22	D4+	O	Focus actuator (4) forward-action output
23	PGND2	—	Ground connection (2) for driver
24	PVCC2	—	Power supply (2) for driver

Troubleshooting Guide

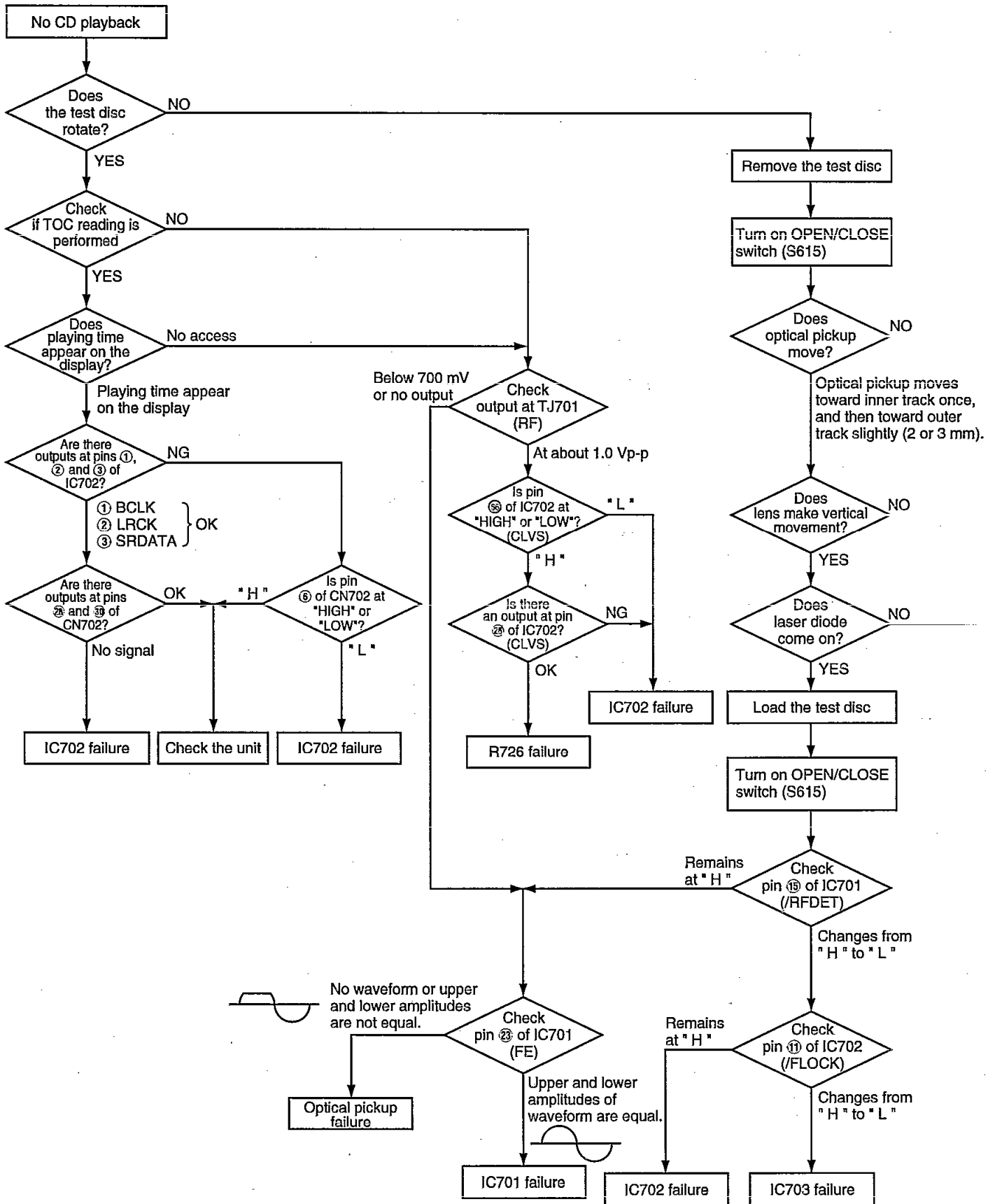

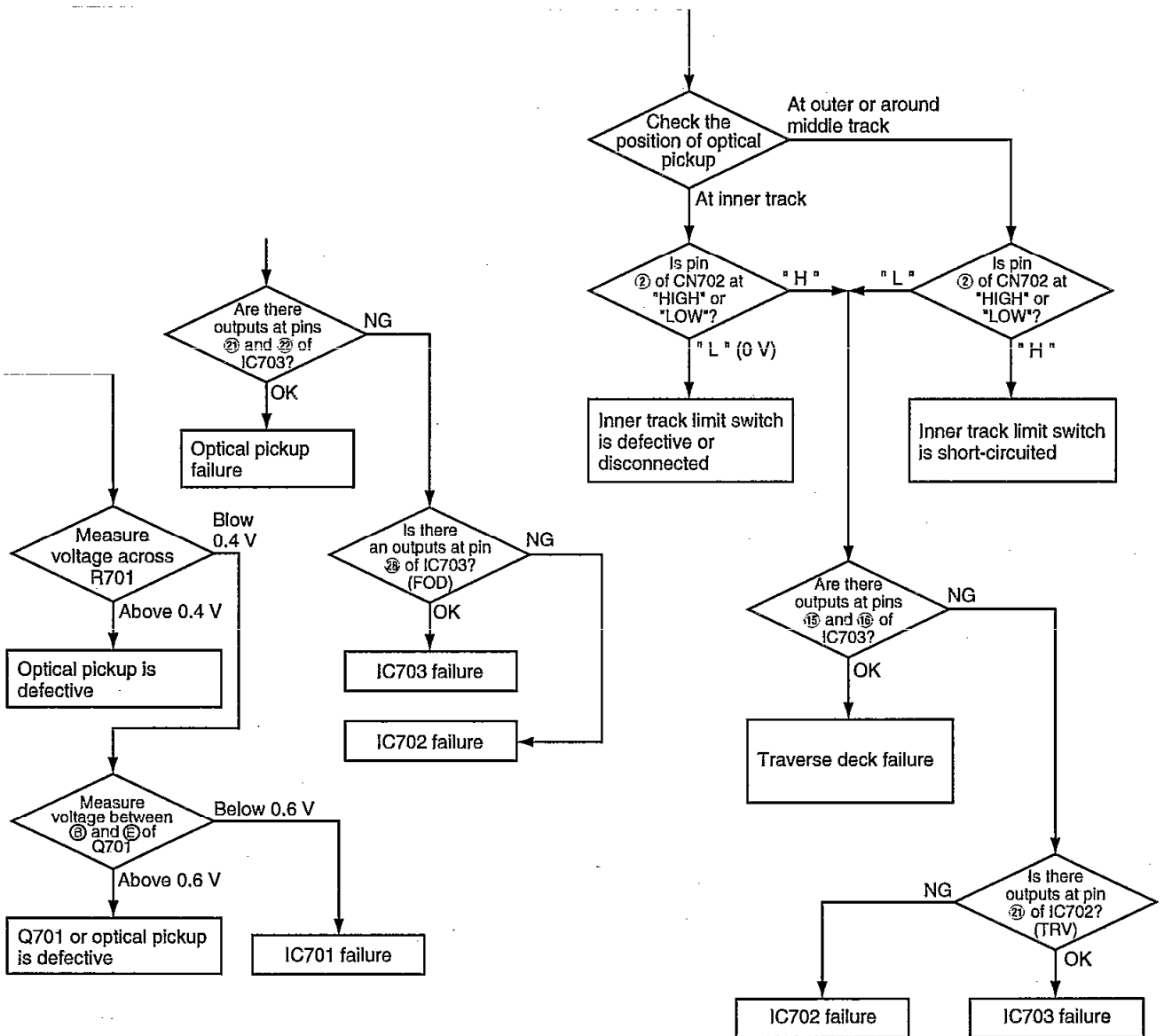

Block Diagram

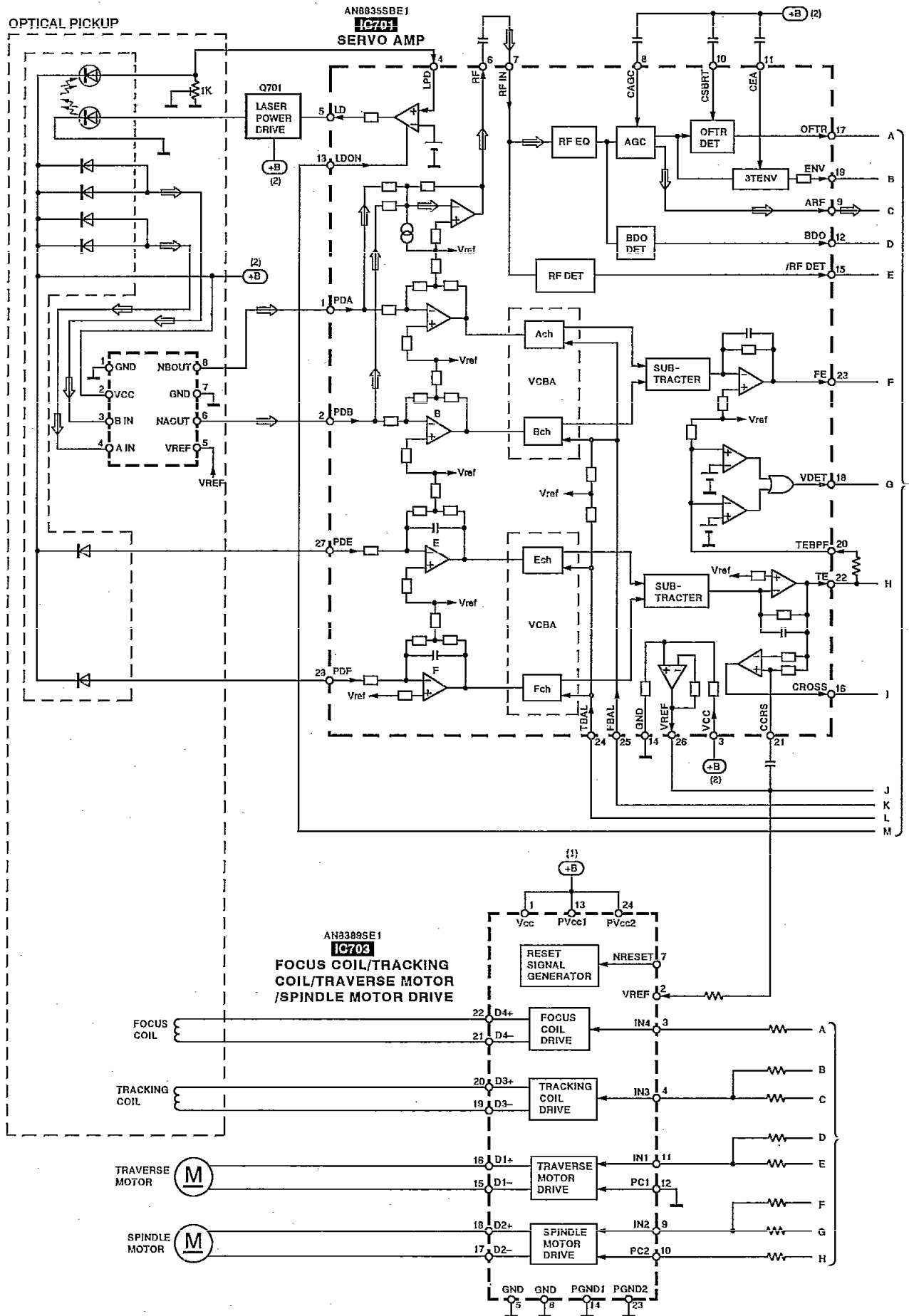

MN662741RPA
[C702]

SERVO PROCESSOR/DIGITAL SIGNAL PROCESSOR/
DIGITAL FILTER/D/A CONVERTER

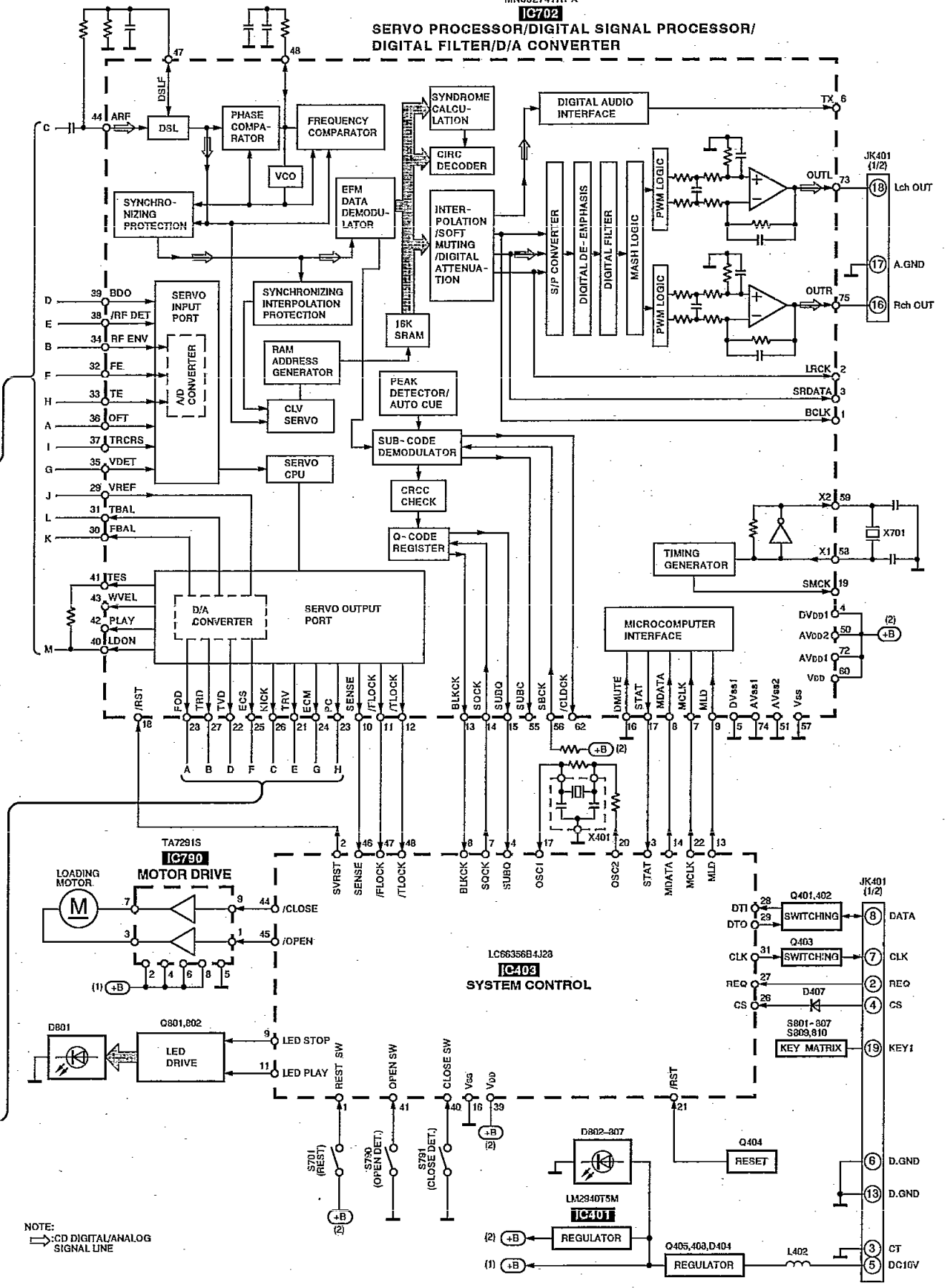

NOTE:
→ CD DIGITAL/ANALOG
SIGNAL LINE

■ Replacement Parts List (Electrical)

Notes: *Important safety notice:

Components identified by Δ mark have special characteristics important for safety.

Furthermore, special parts which have purposes of fire-retardant (resistors), high-quality sound (capacitors), low-noise (resistors), etc. are used.

When replacing any of components, be sure to use only manufacture's specified parts shown in the parts list.

*The parenthesized indications in the Remarks columns specify the areas. (Refer to the cover page for area.)

Parts without these indications can be used for all areas.

* [M] Indicates in Remarks columns parts that are supplied by MESA.

*Warning: This product uses a laser diode. Refer to caution statements on page 2.

*ACHTUNG: Die Lasereinheit nicht zerlegen.

Die Lasereinheit darf nur gegen eine vom Hersteller spezifizierte Einheit ausgetauscht werden.

*The "(SF)" mark denotes the standard part.

Ref. No.	Part No.	Part Name & Description	Remarks	Ref. No.	Part No.	Part Name & Description	Remarks
		INTEGRATED CIRCUIT (S)				EARTH TERMINAL (S)	
IC401Δ	LM2940T5	IC	[M]	E401	SNE1004-2	EARTH TERMINAL	[M]
IC403	LC66356B4J28	IC	[M]			JACK(S)	
IC790	TA7291S	IC	[M]				
		TRANSISTOR(S)					
Q401-403	2SC1740SRSTA	TRANSISTOR	[M]			CD SERVO CIRCUIT	
Q404	DTC114YSTP	TRANSISTOR	[M]			INTEGRATED CIRCUIT(S)	
Q405Δ	2SD1862QRTV6	TRANSISTOR	[M]				
Q408Δ	2SD1862QRTV6	TRANSISTOR	[M]	IC701	AN8835SBE1	IC	[M]
Q801, 802	DTA143XSTP	TRANSISTOR	[M]	IC702	MN662741RPA	IC	[M]
		DIODE (S)		IC703	AN8389SE1	IC	[M]
						TRANSISTOR (S)	
D403	RL1N4003N02	DIODE	[M]				
D404Δ	MTZJ8R2BTA	DIODE	[M]	Q701	2SB709S	TRANSISTOR	[M]
D405, 406	1SS254TA	DIODE	[M]			COIL (S)	
D407-409	MA165	DIODE	[M]				
D801	SPR505MDTT	L. E. D.	[M]	L701	RLBN102V-Y	COIL	[M]
D802-807	LNJ801TPSJA	L. E. D.	[M]			OSCILLATOR (S)	
		COIL (S)					
L402Δ	BL02RN2R62T4	COIL	[M]	X701	RSXB16M9J02T	OSCILLATOR	[M]
L406	ELEXT101KA9	COIL	[M]			SWITCH(ES)	
		OSCILLATOR (S)					
X401	EF0EC4234T3	OSCILLATOR	[M]	S701	RSMD006-P	SW	[M]
		SWITCH(ES)				CONNECTOR (S)	
S790, 791	ESH1A005	SW	[M]	CN701	RJU035T016-1	CONNECTOR (16P)	[M]
S801-807	EVQ21405R	SW	[M]	CN702	RJS1A6723-1Q	CONNECTOR (23P)	[M]
S809, 810	EVQ21405R	SW	[M]				
		CONNECTOR (S)					
CN401	RJP6G18ZA	CONNECTOR (6P)	[M]				
CN402	RJS1A6823	CONNECTOR (23P)	[M]				
CN801, 802	RJS1A6603	CONNECTOR (3P)	[M]				
CP790	RJP6G17ZA	CONNECTOR (6P)	[M]				

Resistors and Capacitors

Notes : * Capacity values are in microfarads (μF) unless specified otherwise, P=Pico-farads (pF) F=Farads (F)
 * Resistance values are in ohms, unless specified otherwise, 1K=1,000(OHM) , 1M=1,000k(OHM)

Ref.No.	Part No.	Values & Remarks	Ref.No.	Part No.	Values & Remarks	Ref.No.	Part No.	Values & Remarks
		RESISTORS	C406	RCE1HKA3R3BG	50V 3.30 Ω			
			C409	ECBT1E103ZF	25V 0.01U Ω			CD SERVO CIRCUIT
			C410	ECA1CM471B	16V 470U Ω			RESISTORS
R403	ERDS2TJ102	1/4W 1K Ω	C412, 413	ECBT1E103ZF	25V 0.01U Ω			
R405	ERDS2TJ103	1/4W 10K Ω	C416	RCE1AKA101BG	10V 100U Ω	R701	ERJ6GEYJ4R7V	1/10W 4.7 Ω
R406	ERDS2TJ473	1/4W 47K Ω	C417, 418	ECBT1H102KB5	50V 1000P Ω	R703	ERJ6GEYJ823	1/10W 82K Ω
R407	ERDS2TJ223	1/4W 22K Ω	C419	ECEA0JKA221B	6.3V 220U Ω	R704	ERJ6GEYJ102A	1/10W 1K Ω
R409, 410	ERDS2TJ103	1/4W 10K Ω	C420	ECEA1AKA221B	10V 220U Ω	R705	ERJ6GEYJ103V	1/10W 10K Ω
R411	ERDS2TJ471	1/4W 470 Ω	C425	ECBT1E103ZF	25V 0.01U Ω	R706	ERJ6GEYJ102A	1/10W 1K Ω
R412	ERDS2TJ101	1/4W 100 Ω	C426	ECBT1H101KB5	50V 100P Ω	R707	ERJ6GEYJ474V	1/10W 470K Ω
R413	ERDS2TJ471	1/4W 470 Ω	C790	ECA1AKF820E	10V 82U Ω	R708	ERJ6GEYJ154V	1/10W 150K Ω
R414	ERDS2TJ102	1/4W 1K Ω	C801	ECBT1H102KB5	50V 1000P Ω	R709	ERJ6GEYJ683V	1/10W 68K Ω
R415	ERDS2TJ105T	1/4W 1M Ω				R711	ERJ6GEYJ154V	1/10W 150K Ω
R418	ERDS2TJ182	1/4W 1.8K Ω				R712	ERJ6GEYJ221V	1/10W 220 Ω
R420	ERDS2TJ103	1/4W 10K Ω				R714	ERJ6GEYJ121V	1/10W 120 Ω
R422, 423	ERDS2TJ472	1/4W 4.7K Ω				R717, 718	ERJ6GEYJ102A	1/10W 1K Ω
R425	ERDS2TJ103	1/4W 10K Ω				R720	ERJ6GEYOR00A	1/10W 0.00 Ω
R426, 427	ERDS2TJ472	1/4W 4.7K Ω				R721	ERJ6GEYJ101V	1/10W 100 Ω
R428	ERDS2TJ103	1/4W 10K Ω				R722	ERJ6GEYJ563V	1/10W 56K Ω
R429	ERDS2TJ471	1/4W 470 Ω				R723	ERJ6GEYJ182V	1/10W 1.8K Ω
R430	ERDS2TJ104	1/4W 100K Ω				R724	ERJ6GEYJ333V	1/10W 33K Ω
R431-434	ERDS2TJ103	1/4W 10K Ω				R725	ERJ6GEYJ472V	1/10W 4.7K Ω
R435-438	ERDS2TJ472	1/4W 4.7K Ω				R726	ERJ6GEYJ473V	1/10W 47K Ω
R439, 440	ERDS2TJ101	1/4W 100 Ω				R727	ERJ6GEYJ822V	1/10W 8.2K Ω
R442	ERDS2TJ271	1/4W 270 Ω				R728	ERJ6GEYJ103V	1/10W 10K Ω
R443	ERDS2TJ6R8	1/4W 6.8 Ω				R731	ERJ6GEYJ822V	1/10W 8.2K Ω
R445	ERDS2TJ1R2	1/4W 1.2 Ω				R735, 736	ERJ6GEYJ101V	1/10W 100 Ω
R448	ERDS2TJ1R2	1/4W 1.2 Ω				R744	ERJ6GEYJ103V	1/10W 10K Ω
R455, 456	ERDS2TJ221	1/4W 220 Ω				R745	ERJ6GEYJ155V	1/10W 1.5M Ω
R457	ERDS2TJ473	1/4W 47K Ω				R748	ERJ6GEYJ182V	1/10W 1.8K Ω
R458	ERDS2TJ102	1/4W 1K Ω				R749	ERJ6GEYJ682V	1/10W 6.8K Ω
R459, 460	ERDS2TJ473	1/4W 47K Ω				R750, 751	ERJ6GEYJ473V	1/10W 47K Ω
R801-804	ERDS2TJ151	1/4W 150 Ω				R752	ERJ8GEYJ220V	1/8W 22 Ω
R805-807	ERDS2TJ181T	1/4W 180 Ω				R770, 771	ERJ6GEYJ155V	1/10W 1.5M Ω
R810	ERDS2TJ122	1/4W 1.2K Ω				R772	ERJ6GEYJ273V	1/10W 27K Ω
R811	ERDS2TJ152	1/4W 1.5K Ω						CHIP JUMPER(S)
R812	ERDS2TJ182	1/4W 1.8K Ω						
R813	ERDS2TJ222	1/4W 2.2K Ω						
R814	ERDS2TJ332	1/4W 3.3K Ω				RJ701-709	ERJ8GEYOR00A	1/8W 0.00 Ω
R815	ERDS2TJ472	1/4W 4.7K Ω				RJ714-717	ERJ8GEYOR00A	1/8W 0.00 Ω
R816	ERDS2TJ682T	1/4W 6.8K Ω				RJ721-724	ERJ6GEYOR00A	1/10W 0.00 Ω
R818	ERDS2TJ123	1/4W 12K Ω				RJ726-731	ERJ6GEYOR00A	1/10W 0.00 Ω
		CAPACITORS						TEST JUMPER
C401	ECBT1E103ZF	25V 0.01U Ω						
C402	ECBT1H104ZF5	50V 0.1U Ω				TJ701, 702	EYF8CU	TEST JUMPER
C403	ECBT1H102KB5	50V 1000P Ω						CAPACITORS
C404	ECBT1E103ZF	25V 0.01U Ω						

■ Replacement Parts List (Cabinet and Loading Unit)

Ref. No.	Part No.	Part Name & Description	Remarks	Ref. No.	Part No.	Part Name & Description	Remarks
		GABINET PARTS				JIG/TOOL	
1	RKMD302-K	CABINET	[M]	SA1	SZZP1054C	TEST DISC	[M]
2	RHD30007-K1	SCREW	[M]	SA2	RFKXPG671	GREASE	[M]
3	XTB3+8JFZ	SCREW	[M]				
4	REX0510	WIRE ASS'Y (6P)	[M]				
5	REZ0537	FFC	[M]				
6	XTBS3+8JFZ1	SCREW	[M]				
7	RGRD217A-D	REAR GRILL ASS'Y	[M]				
8	RGKD893-K	TRAY ORNAMENT	[M]				
9	RYP0732-K	FRONT PANEL ASS'Y	[M]				
9-1	RGC0013-S	DISC MIRROR	[M]				
9-2	RKWD505-Q	ORNAMENT PANEL	[M]				
10	RWJ1806130KQ	FLAT CABLE (#801/6P)	[M]				
11	RYKD633-K2J	BOTTOM BOARD ASS'Y	[M]				
11-1	SHG1654	RUBBER	[M]				
		LOADING MECHANISM					
301	RFKJXDT07-K	LOADING CHASSIS ASS'Y	[M]				
301-1	RDG0142	GEAR	[M]				
301-2	RDG0193	GEAR	[M]				
301-3	RDPO065	PULLEY	[M]				
302	REMD019	MOTOR	[M]				
303	RMKD255	BELT COVER	[M]				
304	RGQ0144-K	DISC TRAY	[M]				
305△	RAE0150Z	TRAVERSE DECK	[M]				
305-1	SHGD113-1	RUBBER	[M]				
305-2	SNSD38	SCREW	[M]				
306	RMS0350	PIN (A)	[M]				
307	RMS0123-1	PIN (B)	[M]				
308	RME0109	SPRING (A)	[M]				
309	RME0142	SPRING (B)	[M]				
310	RMR0698-K	TRAVERSE CHASSIS	[M]				
311	XIV2+6G	SCREW	[M]				
312	RME0063	SPRING	[M]				
313	RMMD079-1	SLIDE PLATE	[M]				
314	RML0178-1	LEVER	[M]				
315	RFKNLPG440-K	GEAR ASS'Y	[M]				
316	RHD20009-1	SCREW	[M]				
317	RME0087	SPRING	[M]				
318	RML0349	LEVER	[M]				
319	RMMD059-1	SLIDE PLATE	[M]				
320	RMR0334	HOLDER	[M]				
321	RFM245ZA	MAGNET	[M]				
322	RXQ0380	MAGNET HOLDER	[M]				
323	XTN2+6G	SCREW	[M]				
324	RMA0793-1	CLAMPER	[M]				
325	XYN2+F6FZ	SCREW	[M]				
326	RMGD158	BELT	[M]				
327	XTN2+6G	SCREW	[M]				