

CMT SHEET NAME	REF AREA
<i>/sys/cmt_if/prod_test_pattern</i>	<i>2060-2069</i>
<i>/sys/cmt_if/battery_conn</i>	<i>2070-2099</i>
<i>/sys/cmt_if/audio</i>	<i>2000-2029</i>
<i>/sys/cmt_if/audio</i>	<i>2100-2199</i>
<i>/sys/cmt_if/itu</i>	<i>2400-2499</i>
<i>/sys/cmt_if/camera</i>	<i>2500-2599</i>
<i>/sys/cmt_if/sim</i>	<i>2700-2799</i>
<i>/sys/cmt_if/emu_rap</i>	<i>3100-3120</i>
<i>/sys/cmt_if/wing</i>	<i>4000-4099</i>
<i>/sys/cmt_if/lid</i>	<i>3800-3899</i>
<i>/sys/cmt_if/bt</i>	<i>6000-6099</i>
<i>/sys/cmt_if/wlan</i>	<i>6300-6510</i>
<i>/sys/cmt_if/conn/charger-USB</i>	<i>2030-2039</i>

CMT SHEET NAME	REF AREA
<i>/sys/cmt_engine/power/vilma</i>	<i>2200-2299</i>
<i>/sys/cmt_engine/power/betty</i>	<i>2300-2389</i>
<i>/sys/cmt_engine/power/coreps</i>	<i>2390-2399</i>
<i>/sys/cmt_engine/digi/rapido</i>	<i>2800-2849</i>
<i>/sys/cmt_engine/digi/geniomux</i>	<i>2850-2899</i>
<i>/sys/cmt_engine/digi/mem_cmt/combo</i>	<i>3000-3099</i>
<i>/sys/cmt_engine/digi/mem_cmt/mass_memory</i>	<i>3200-3299</i>

RF SHEET NAME	REF AREA
<i>/RF</i>	<i>7500-7599</i>
<i>/MUTANT</i>	<i>8000-8010</i>

Antenna switch

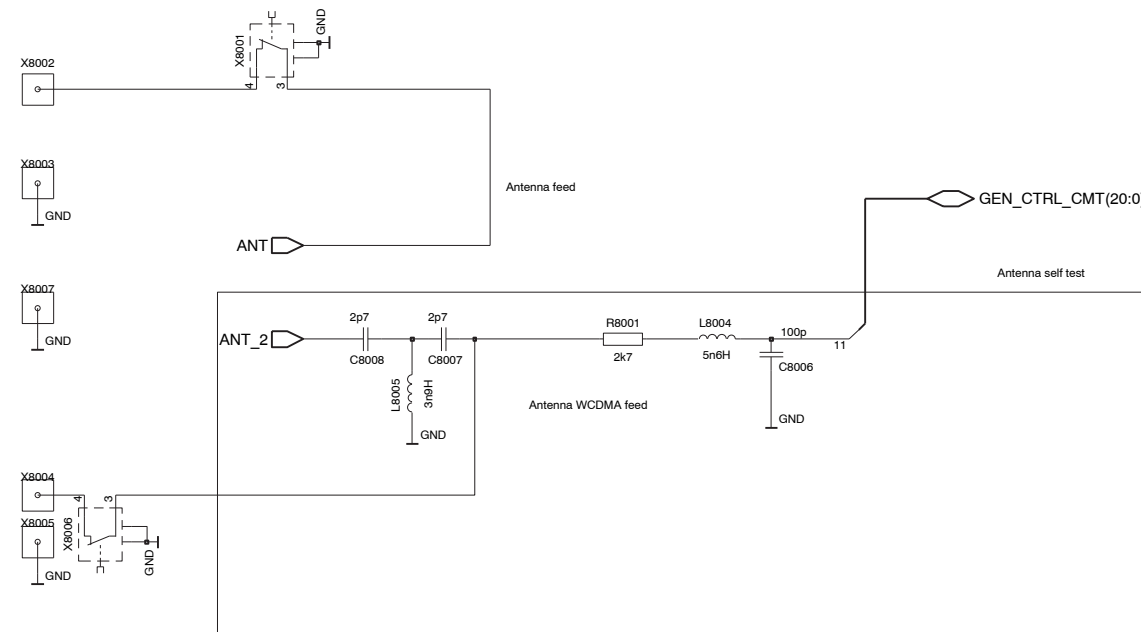
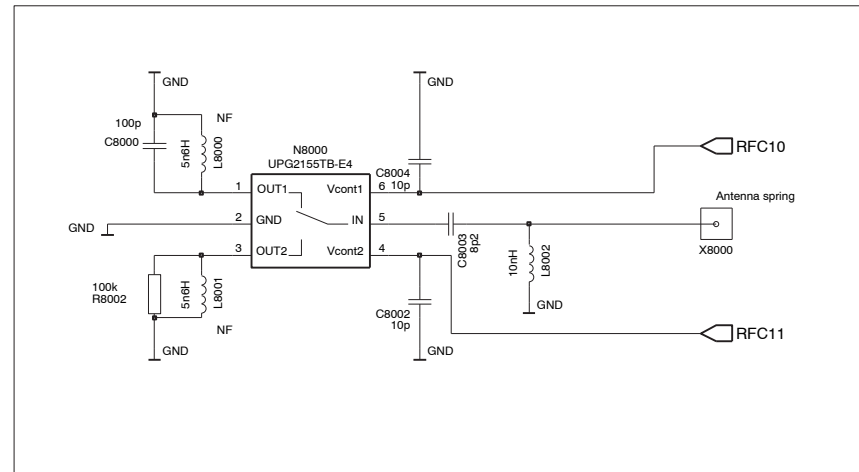

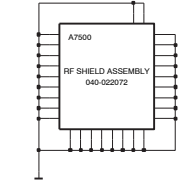
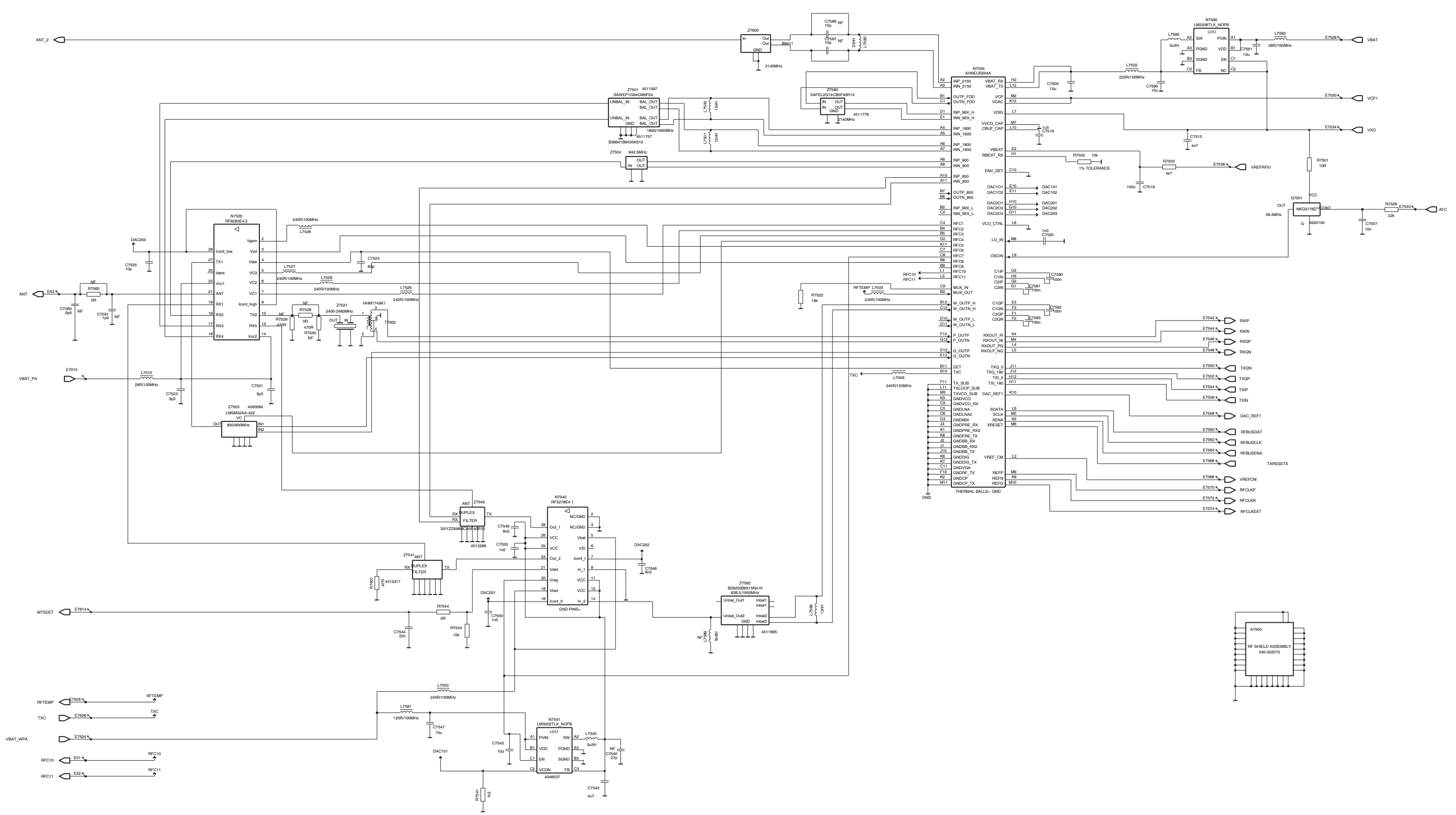

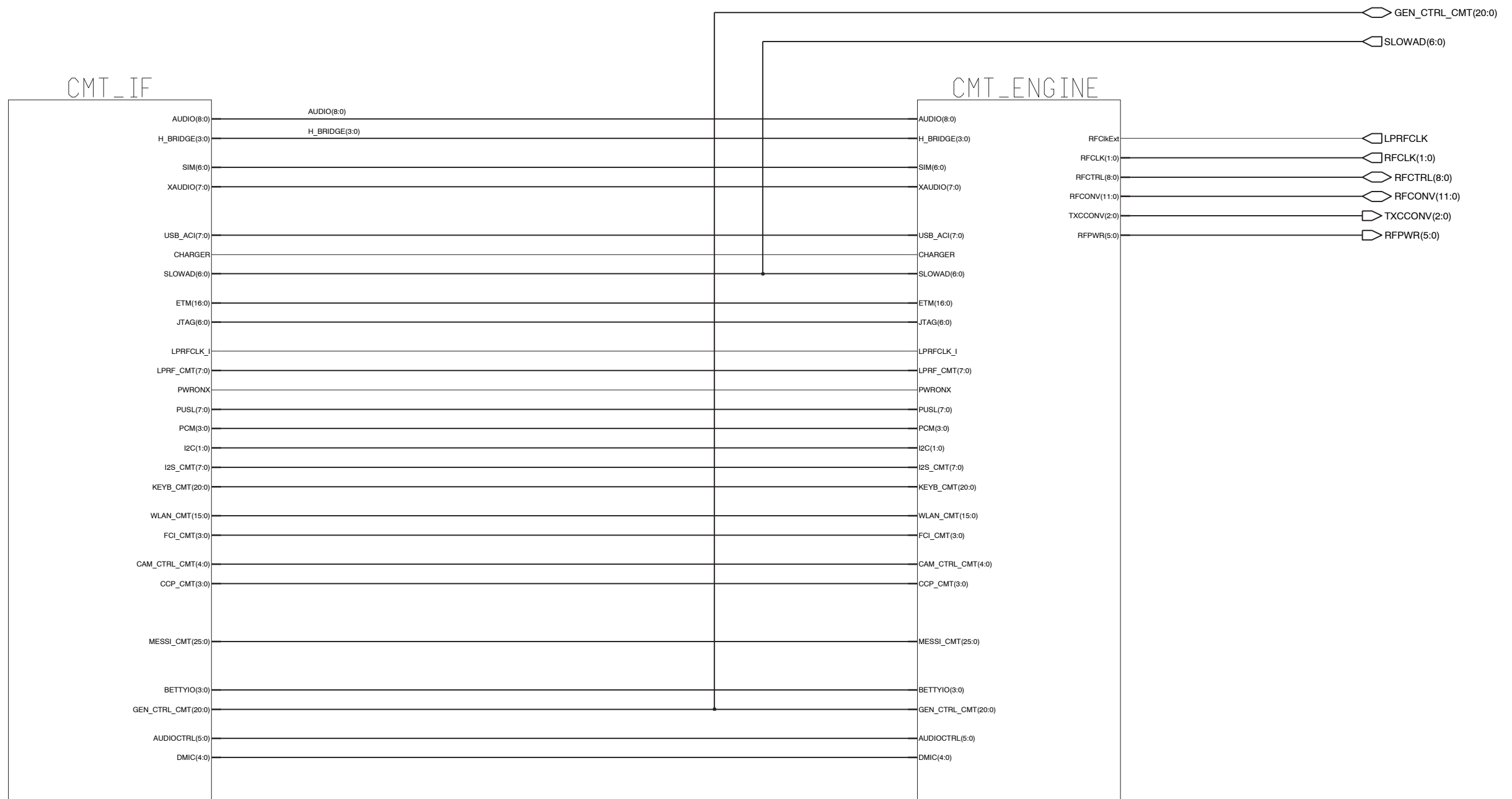

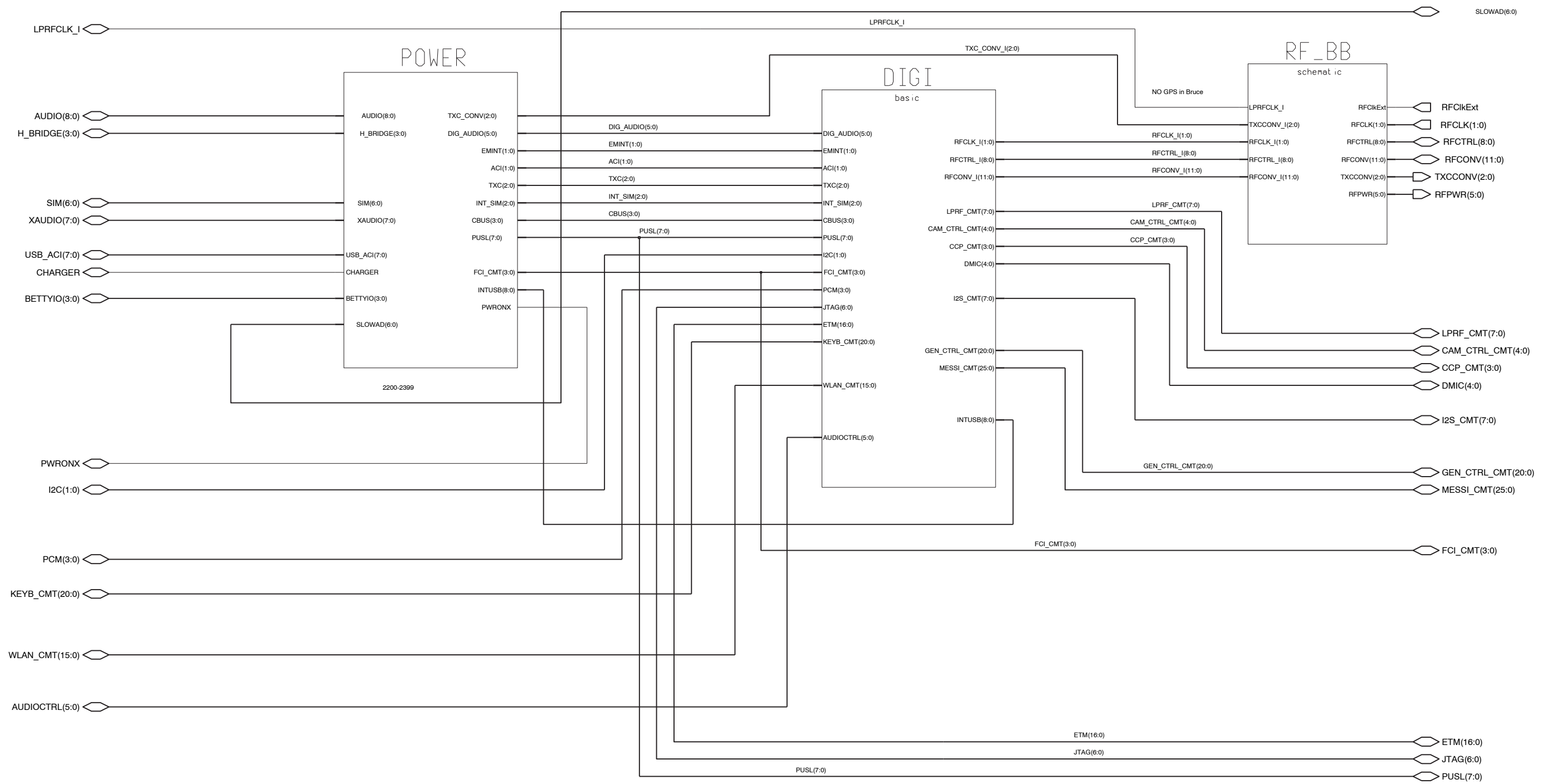

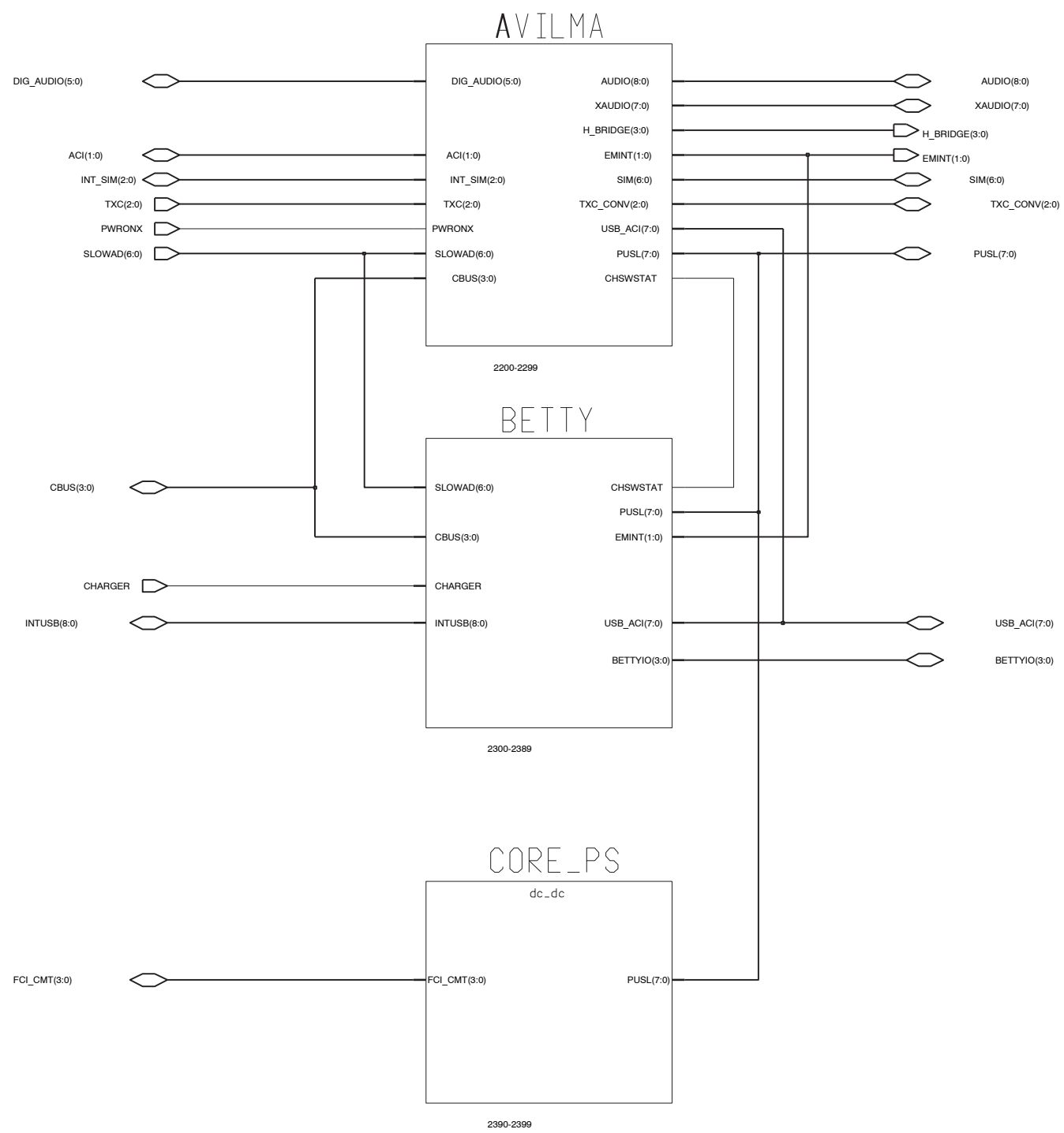

AVILMA used for SIGNATURE !!!

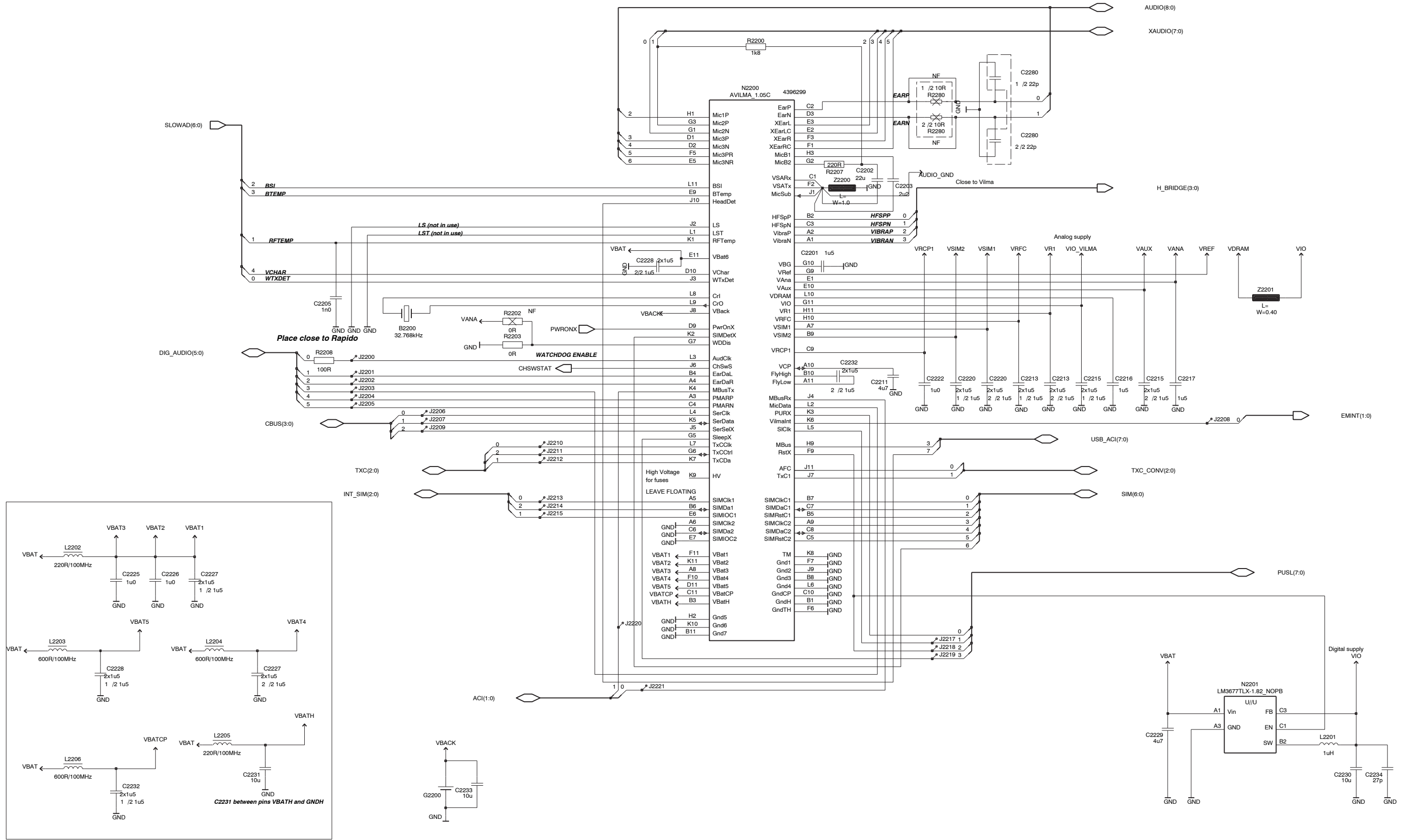

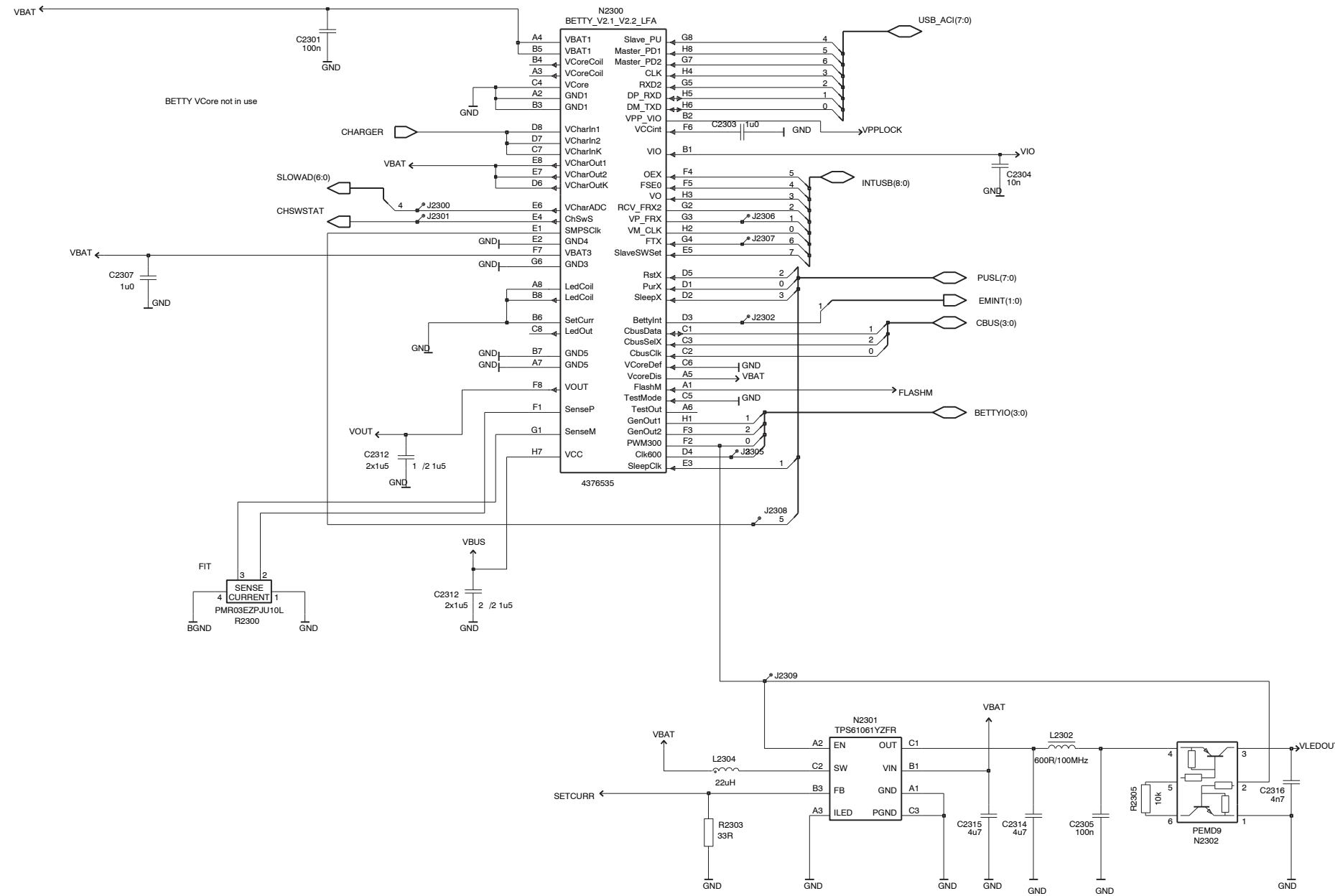

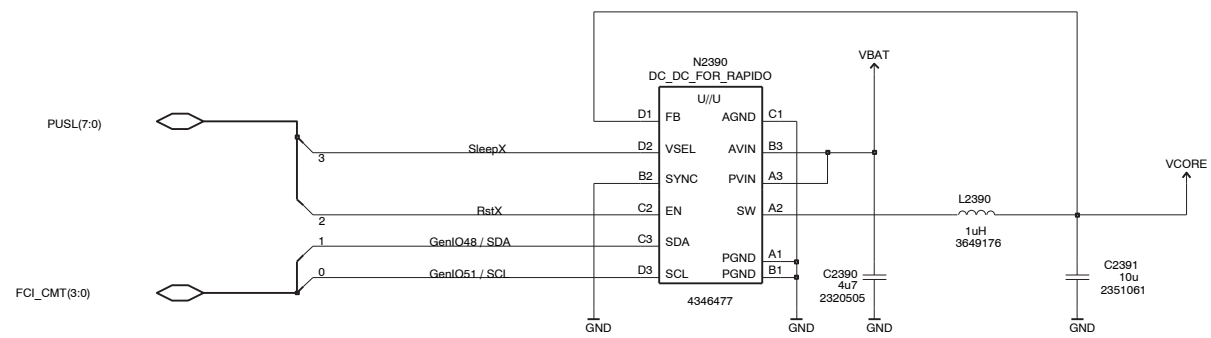

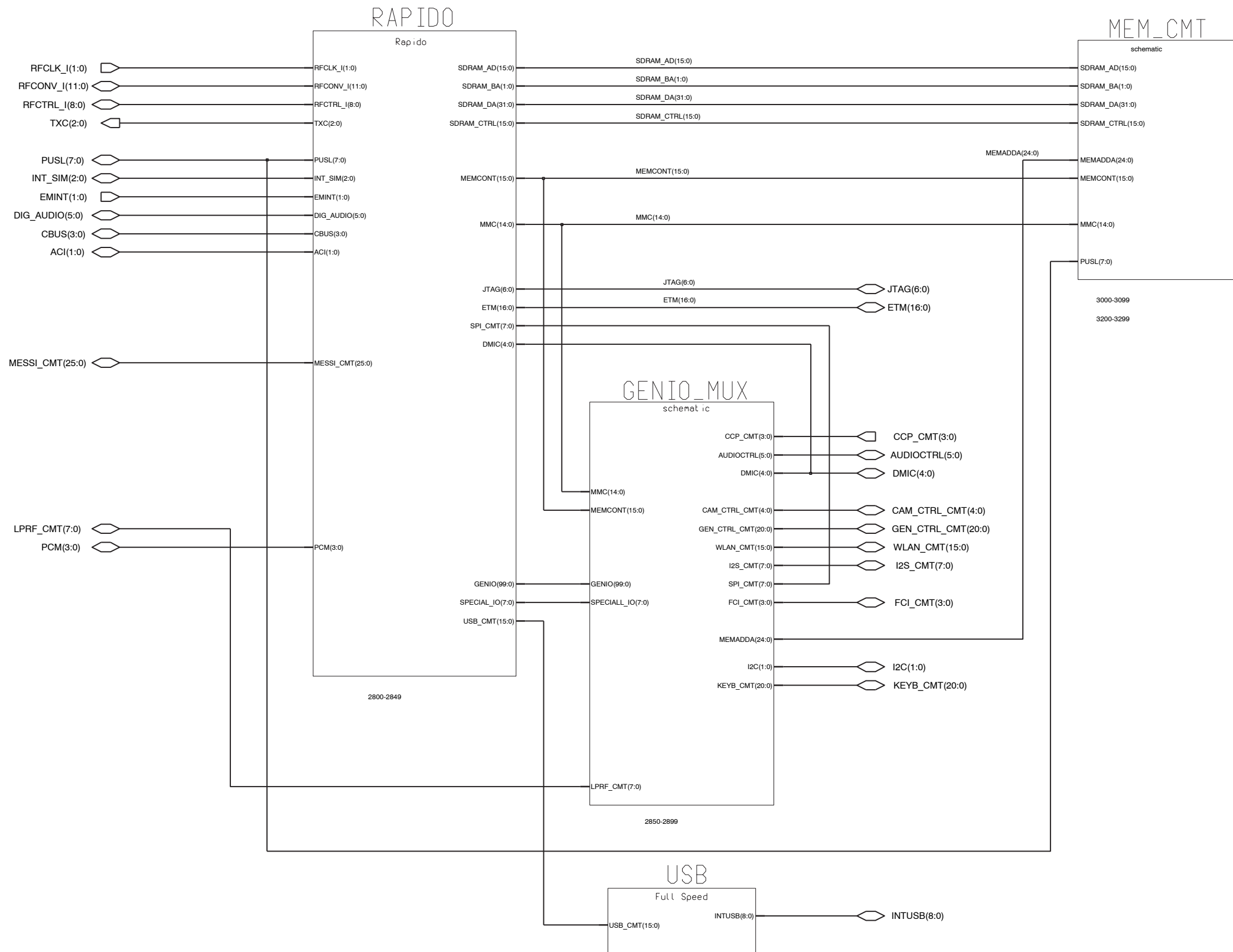

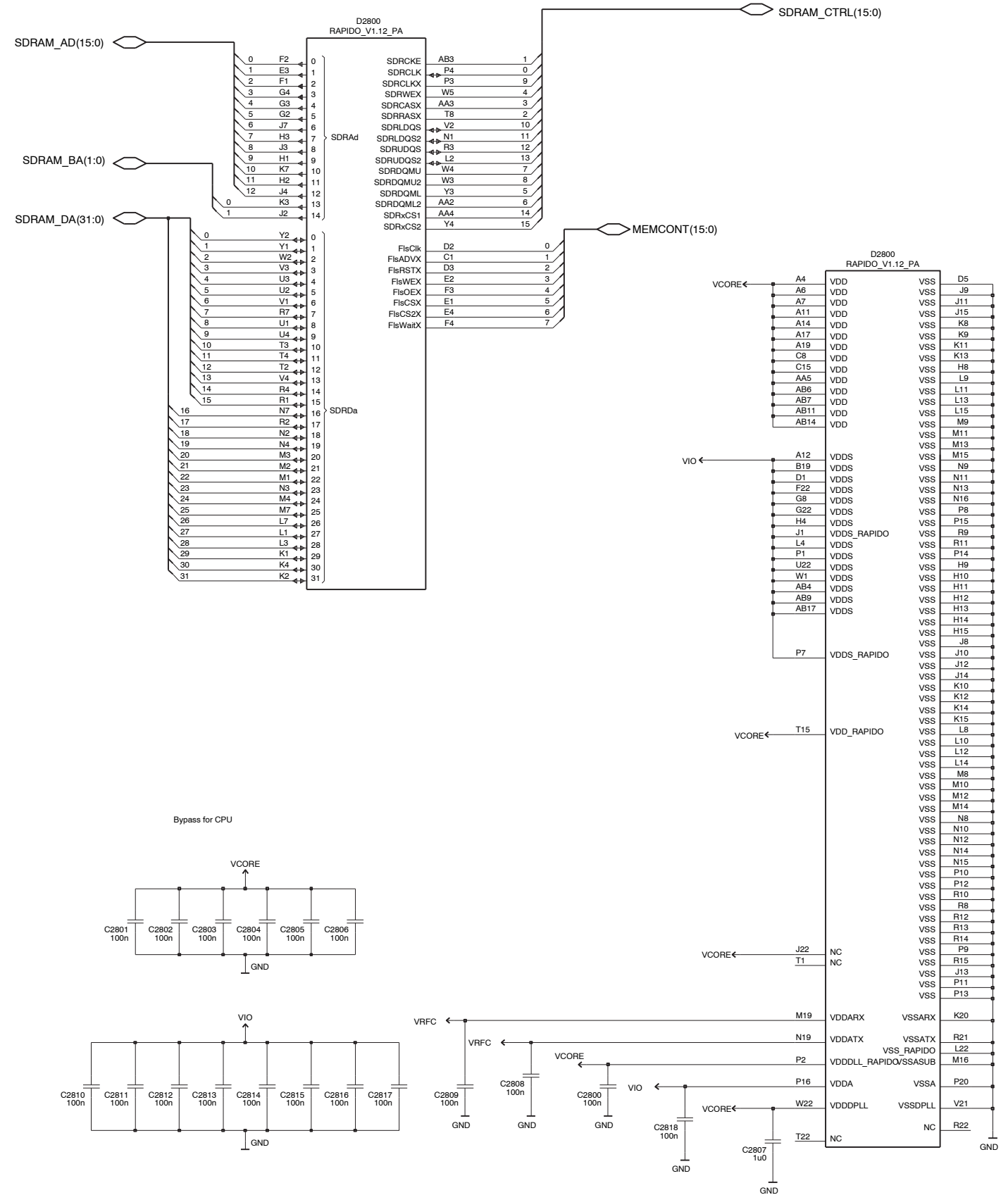
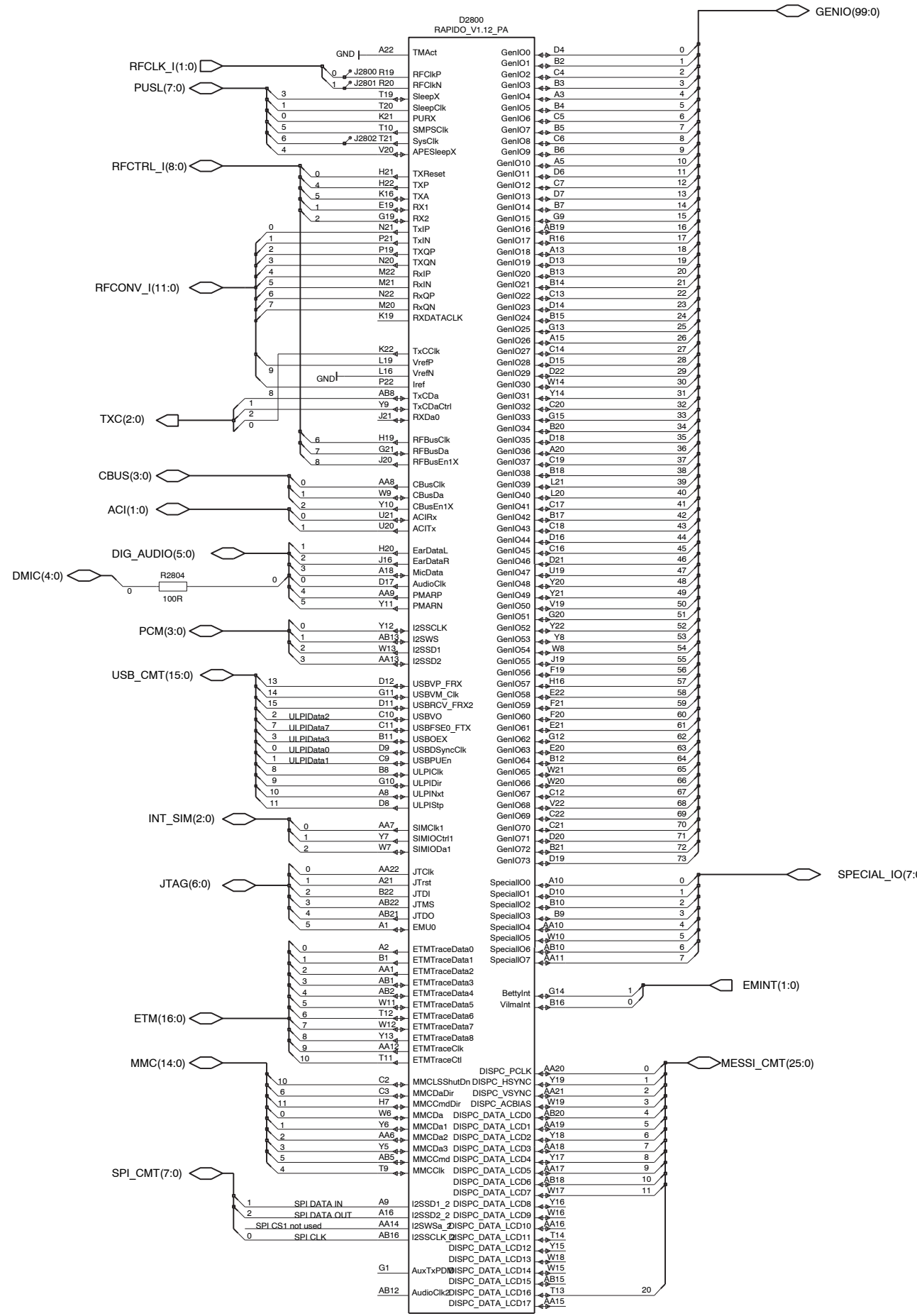

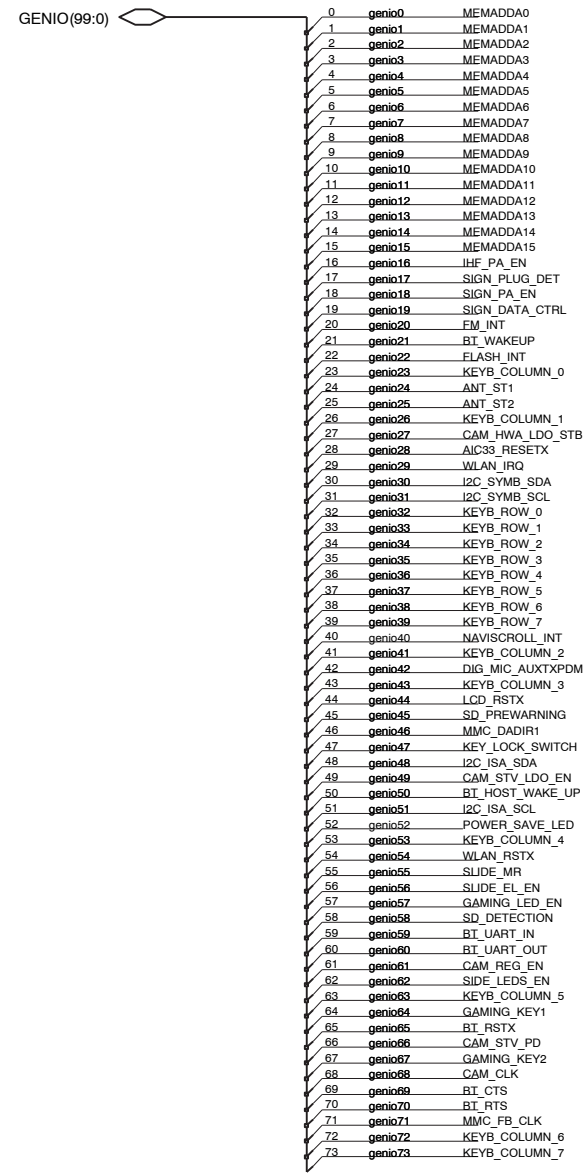

From RAPIDO sheet

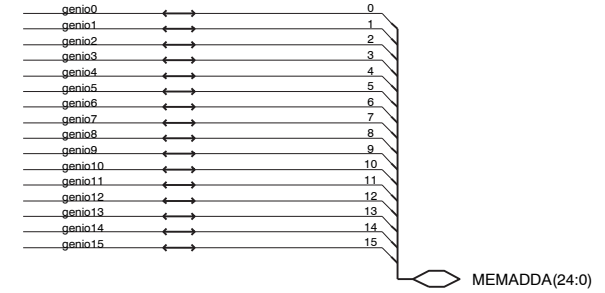
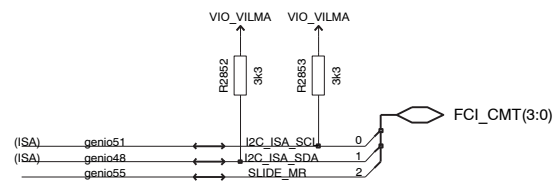
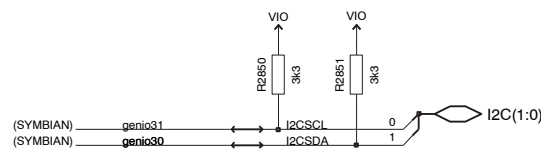
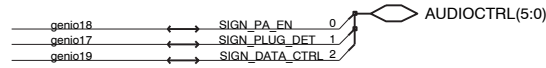
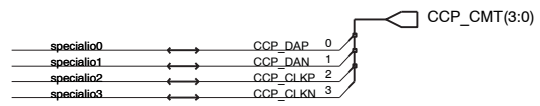
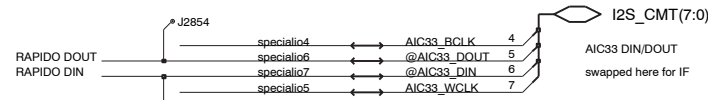
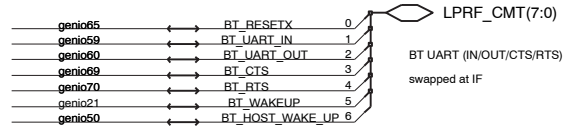
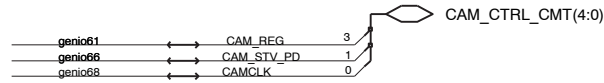
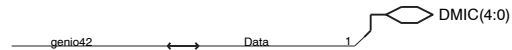
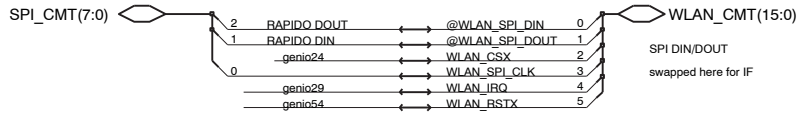

MEMADDA(24:0)

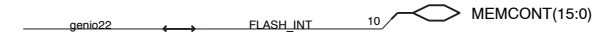

MEMCONT(15:0)



MMC(14:0)

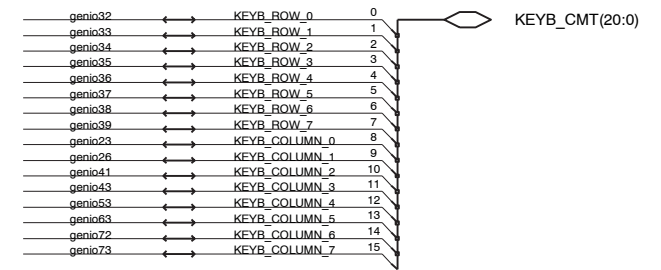

KEYB_CMT(20:0)

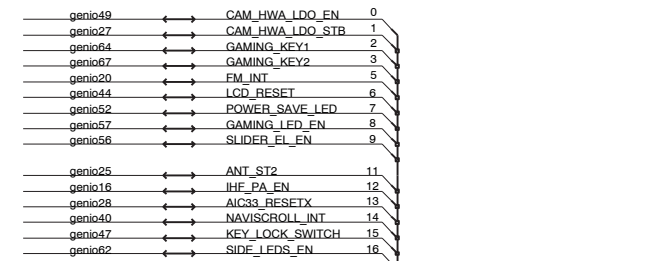

GEN_CTRL_CMT(20:0)

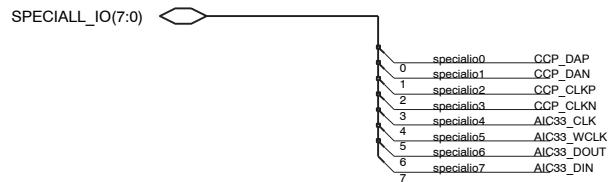

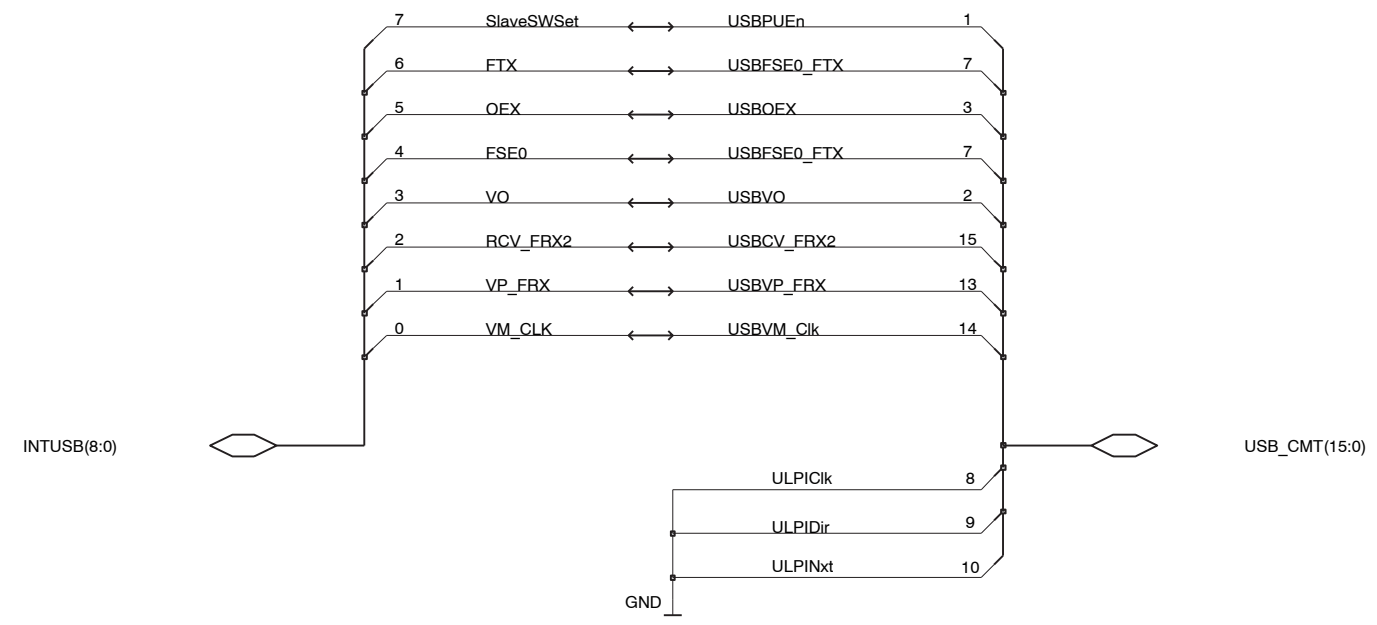

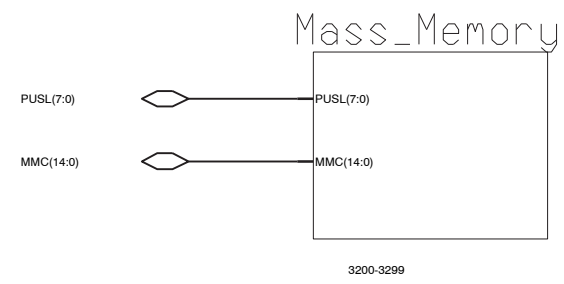
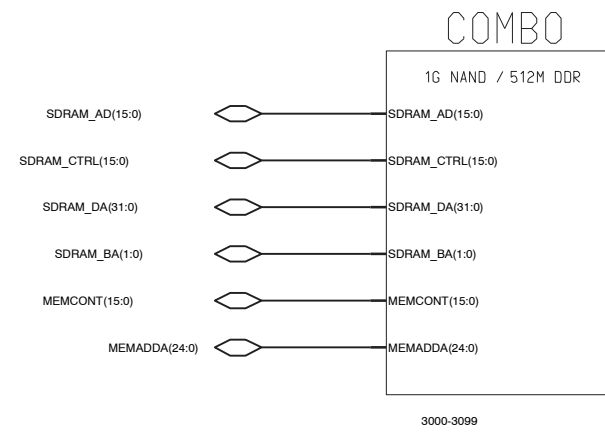

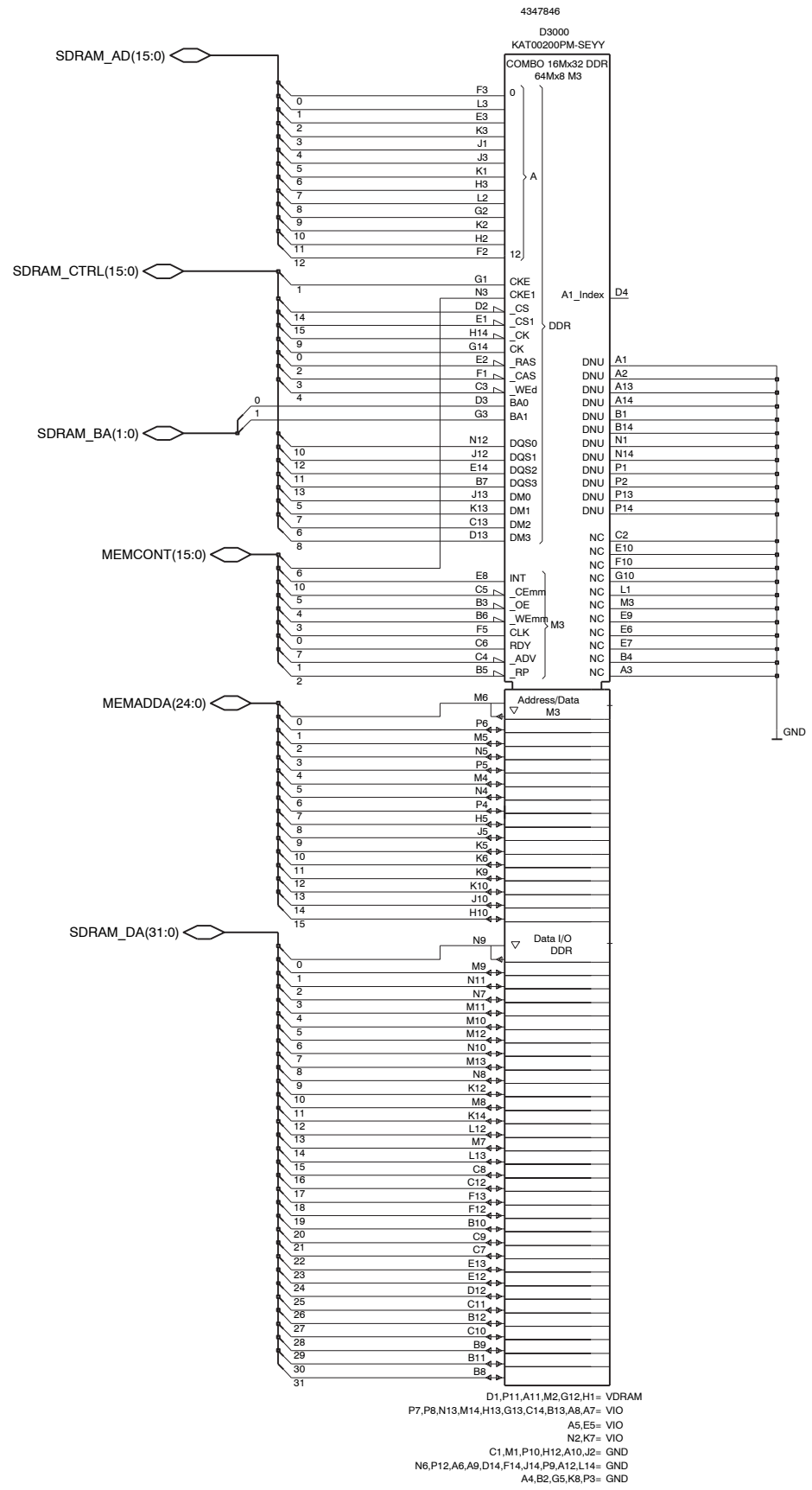
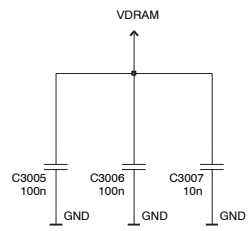
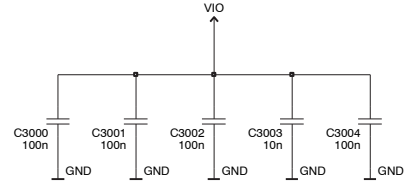

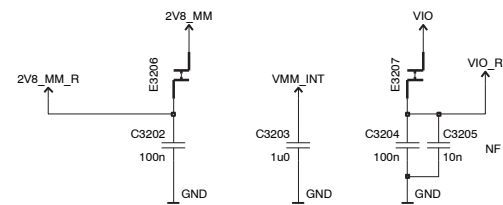
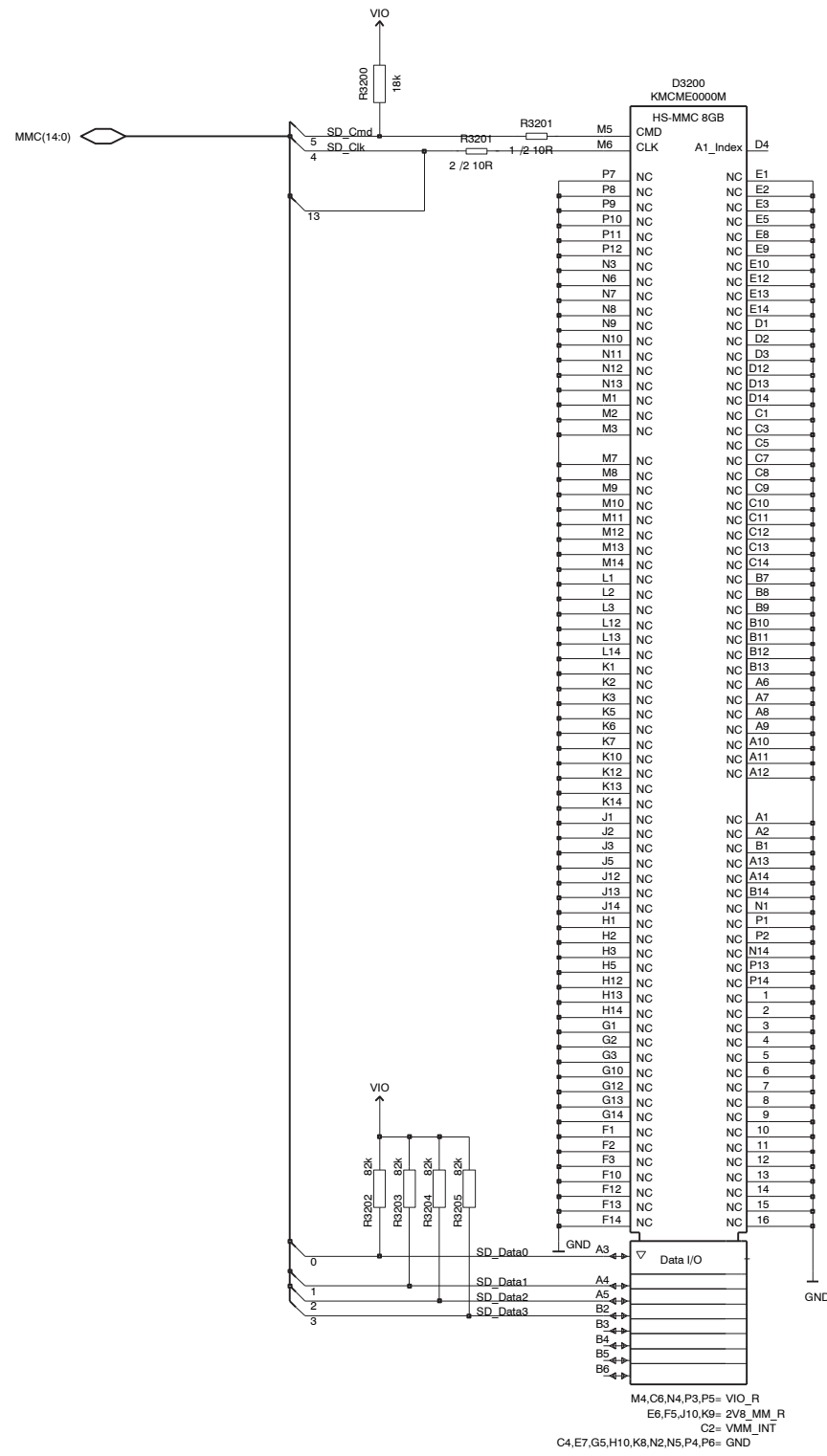
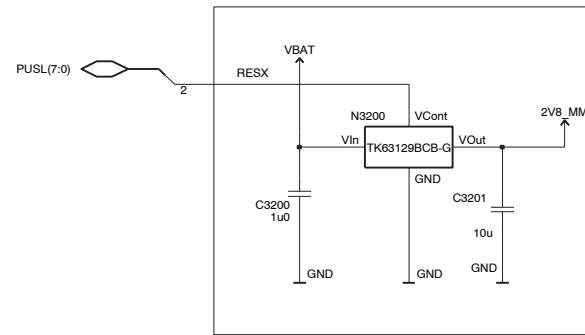

CBB5X

TOP SHEET

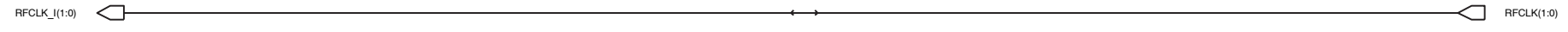

Own CLK on Wlan-sheet

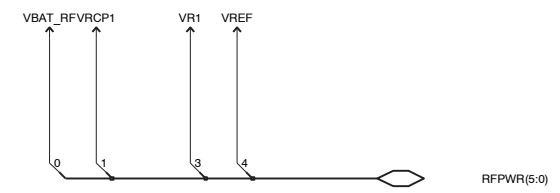
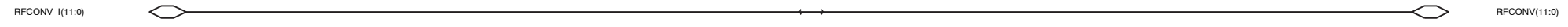

VRCP2 removed from VILMA
also removed from RF IF

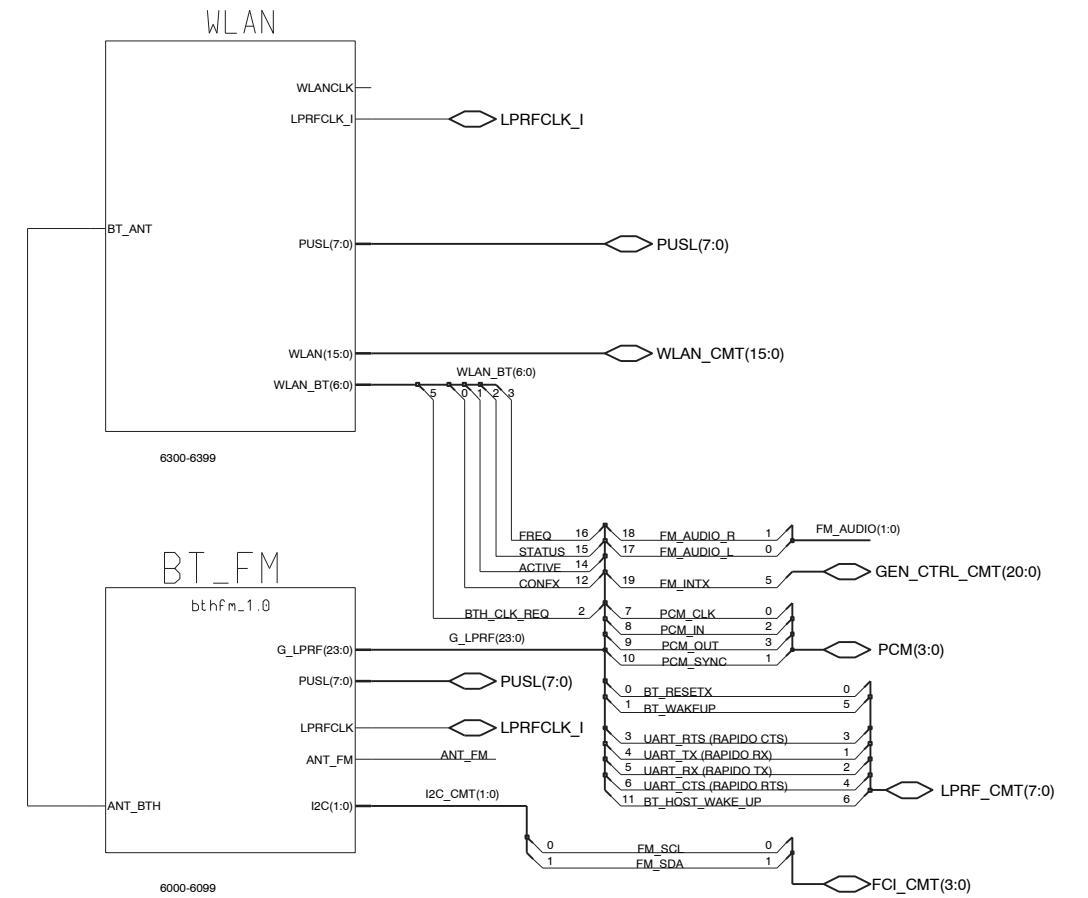
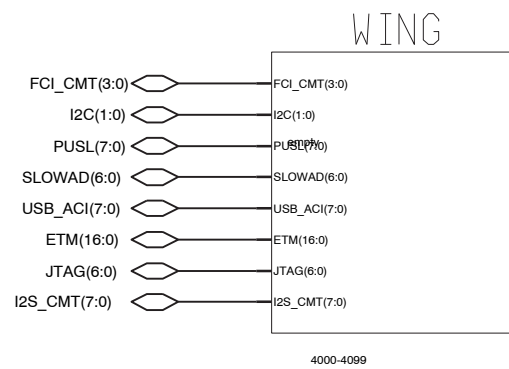
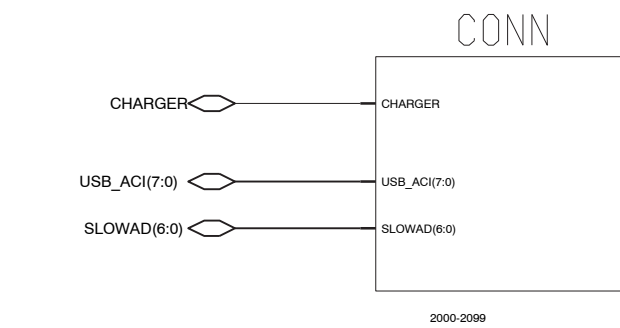
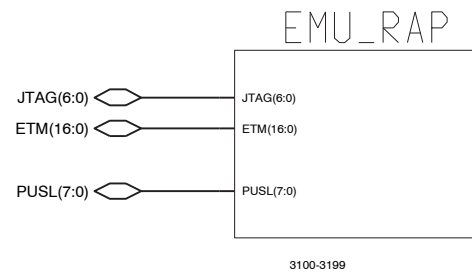
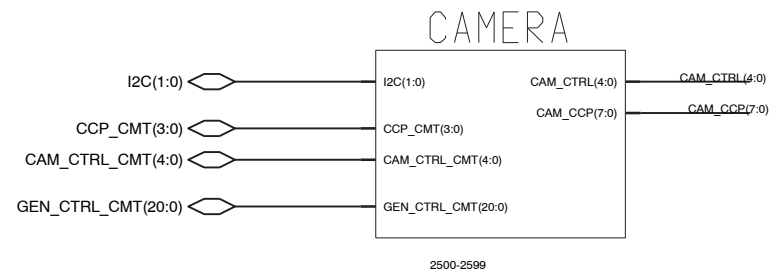
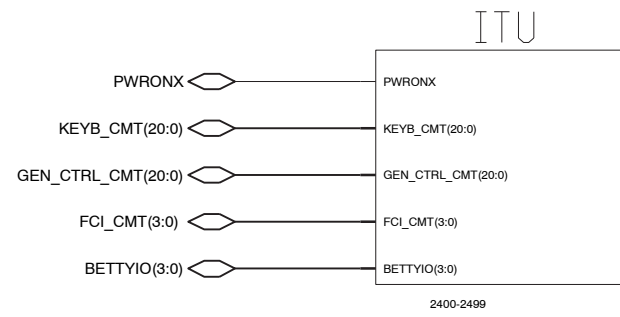
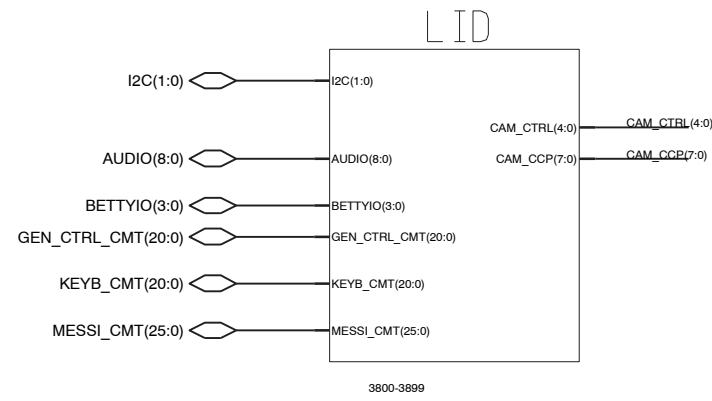
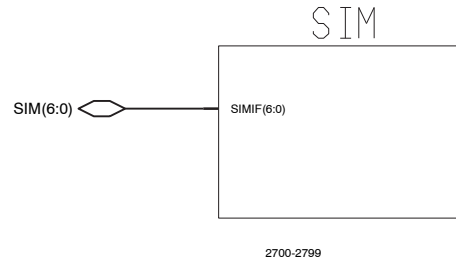
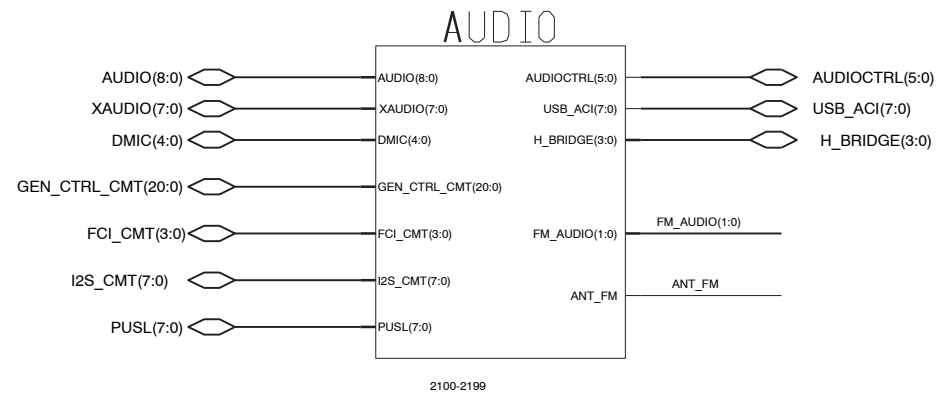

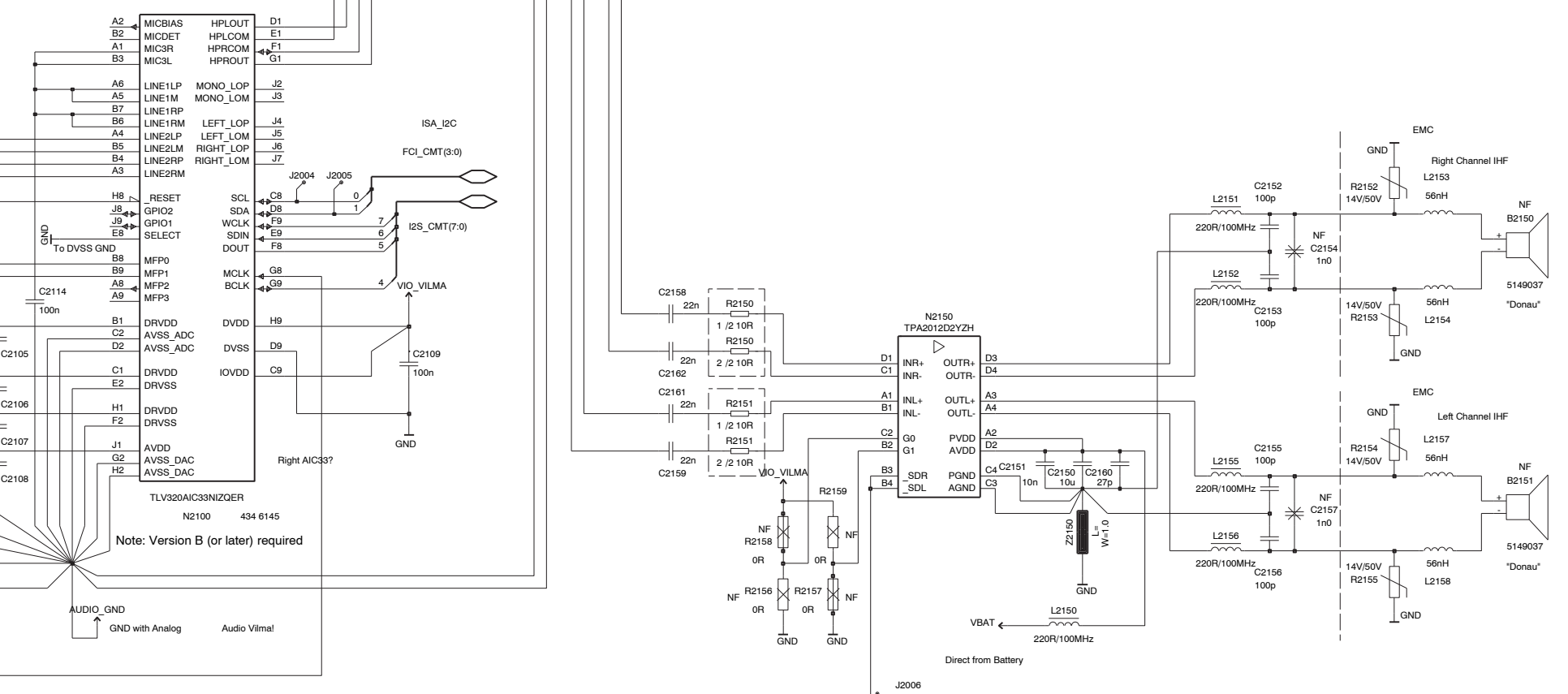
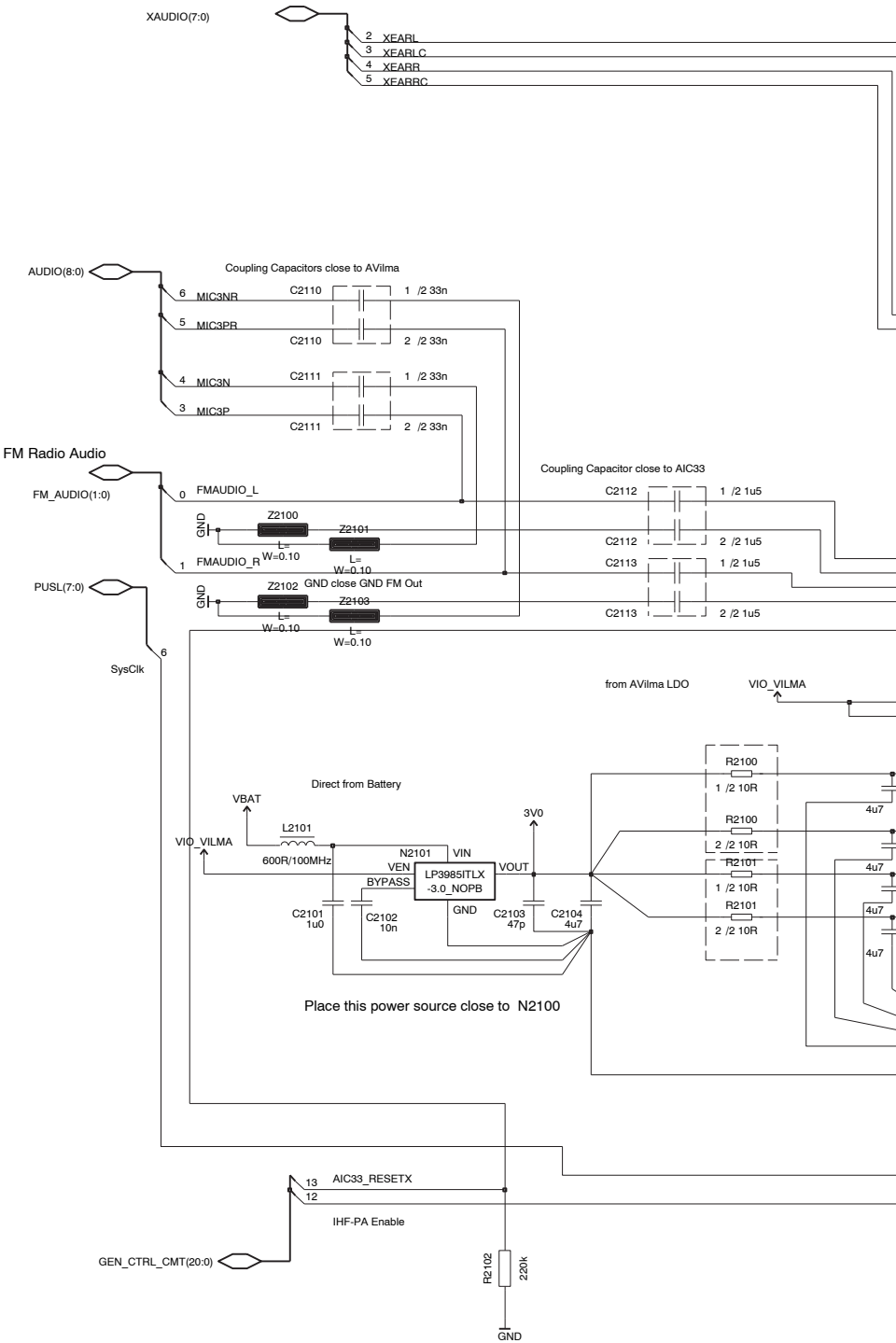
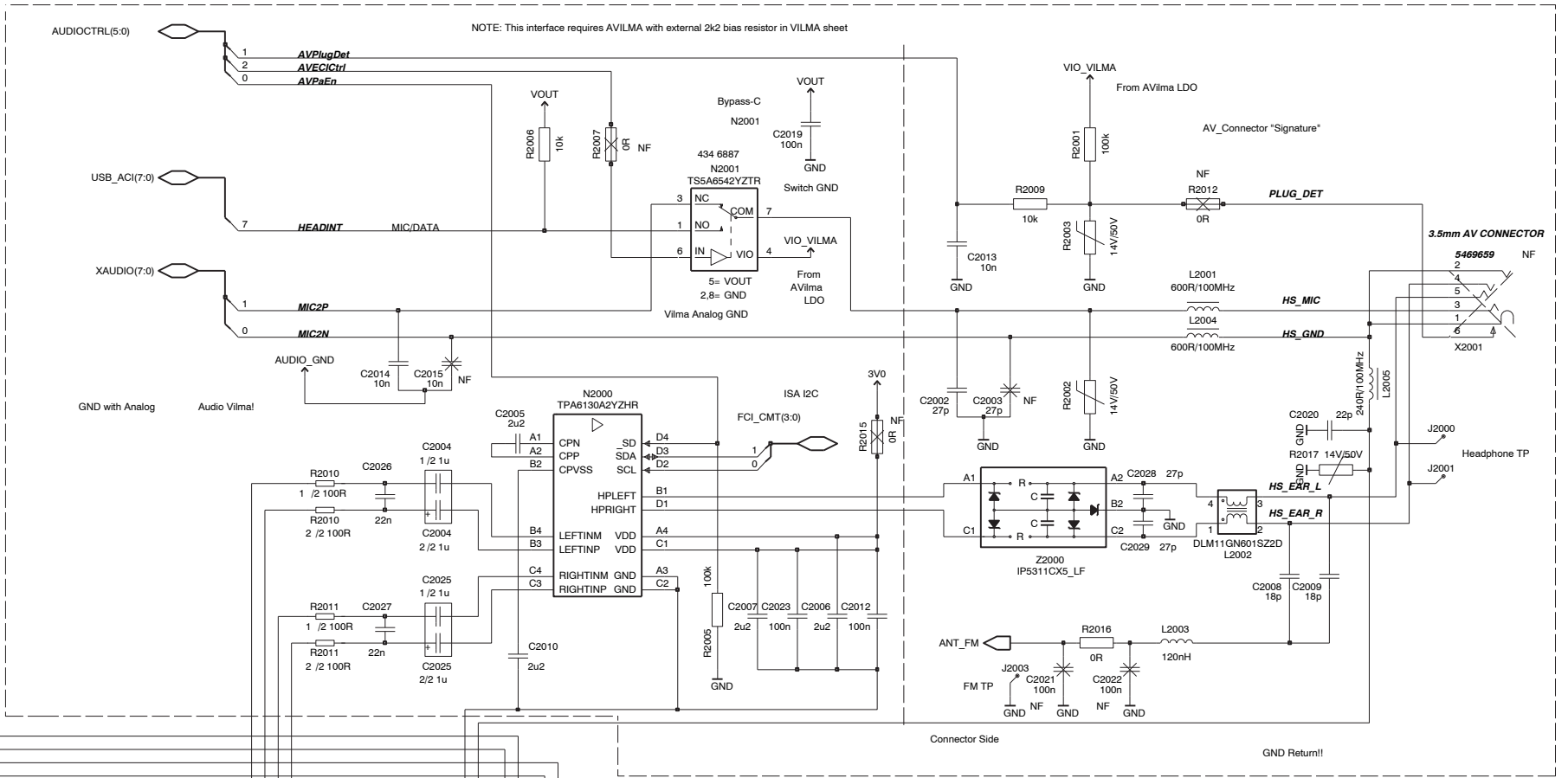
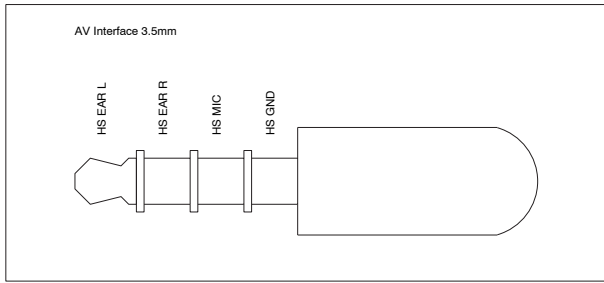

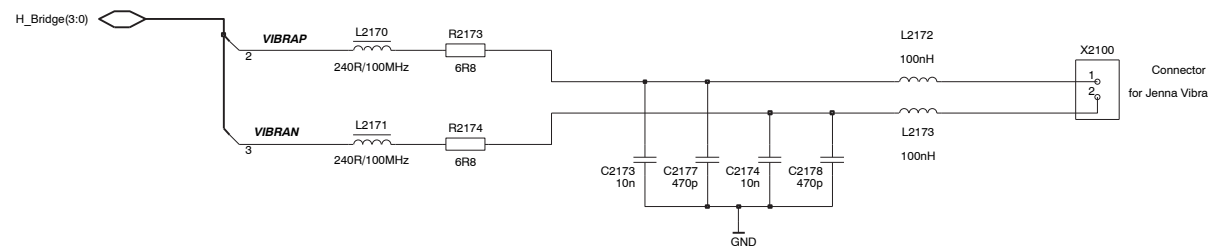
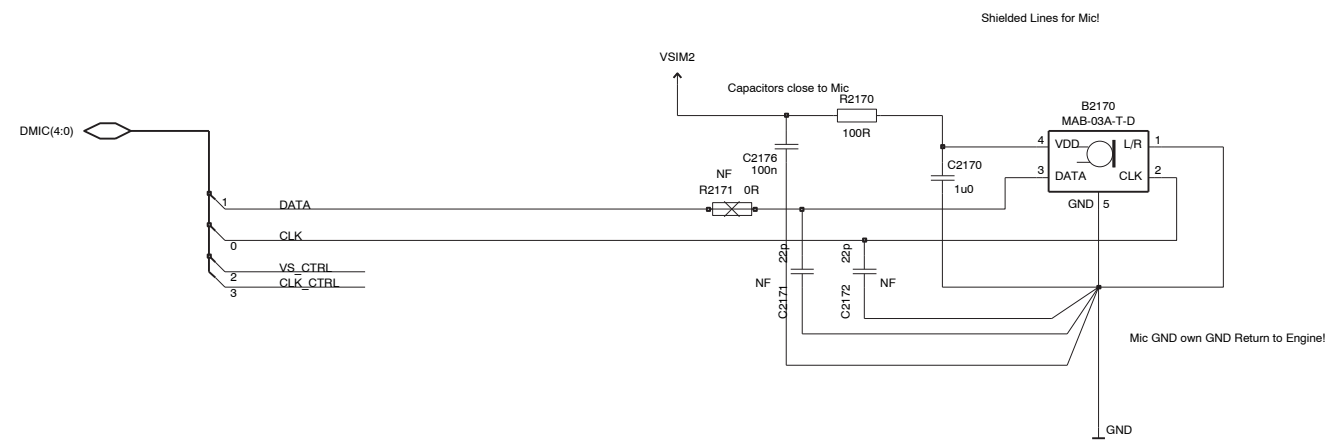

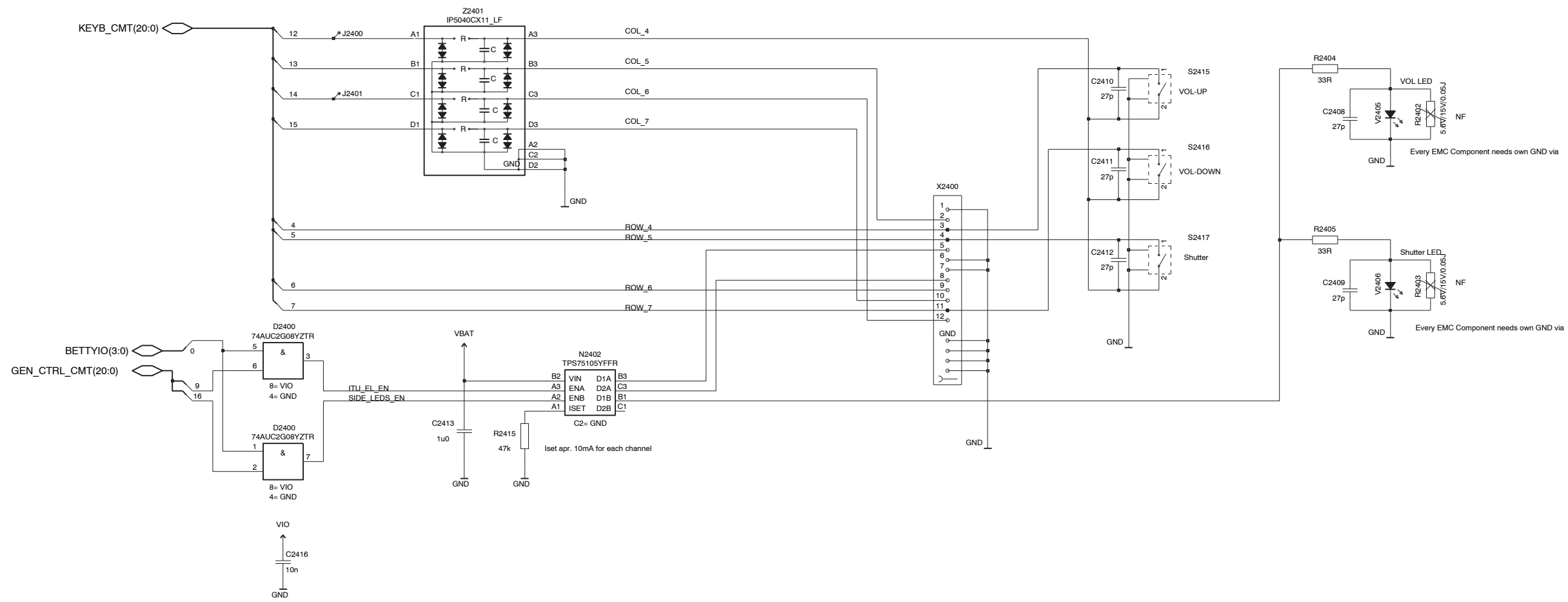
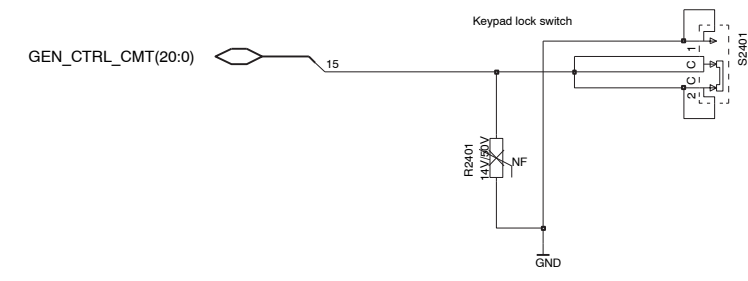
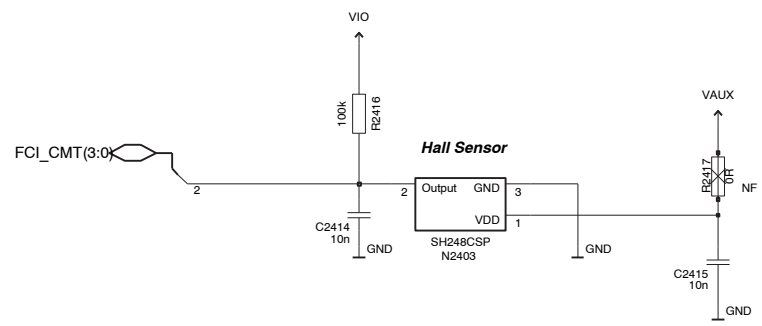
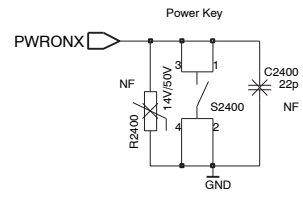

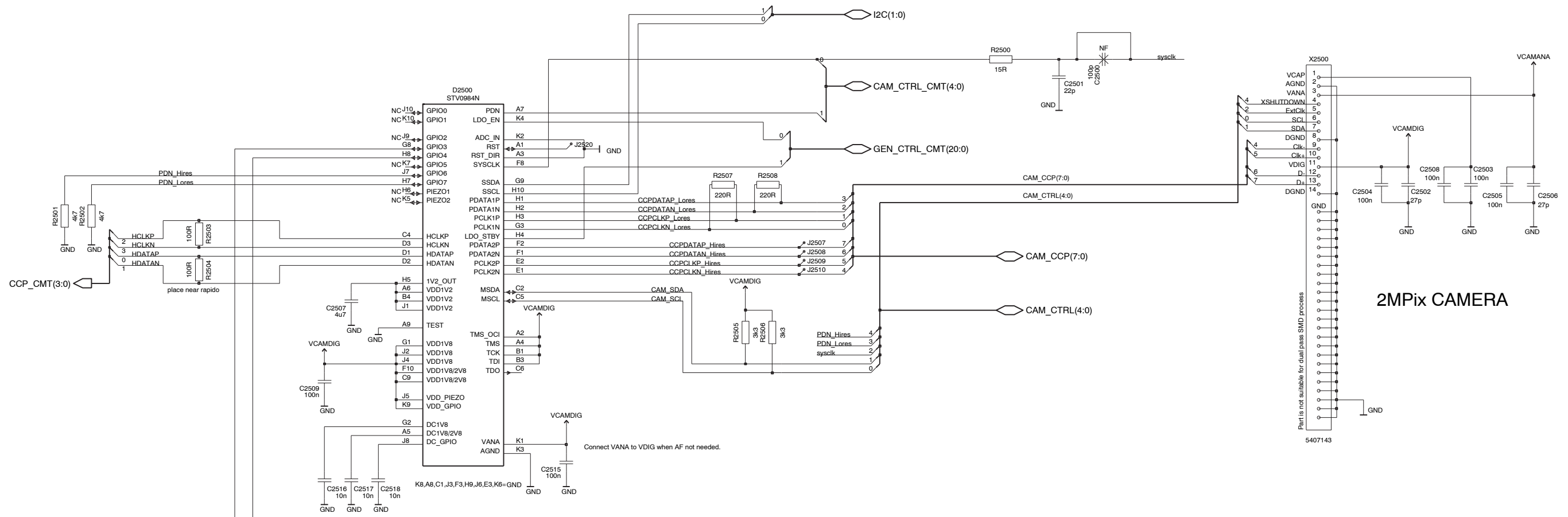

2MPiX CAMERA

Flash LED

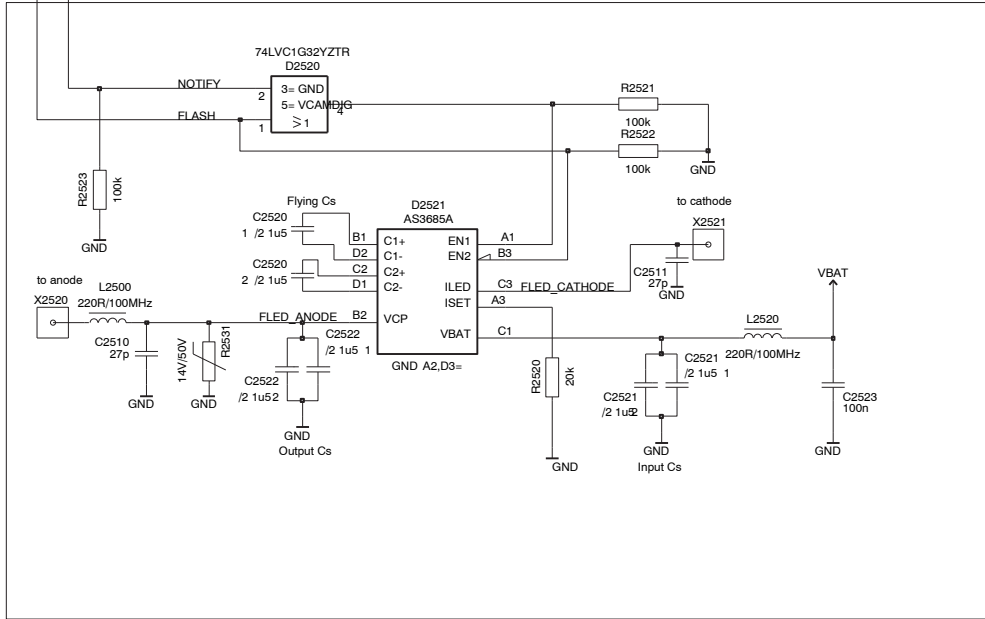

Camera Power Supply

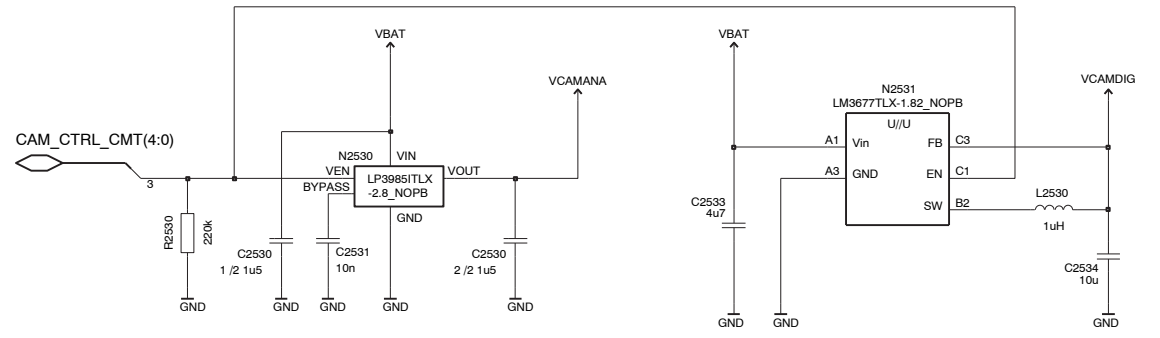

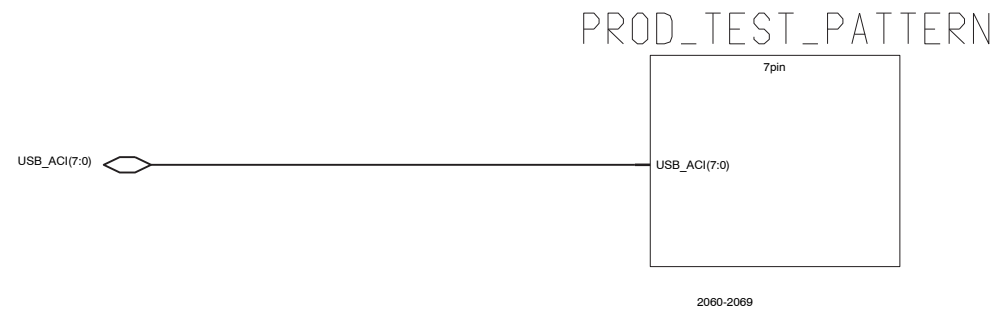
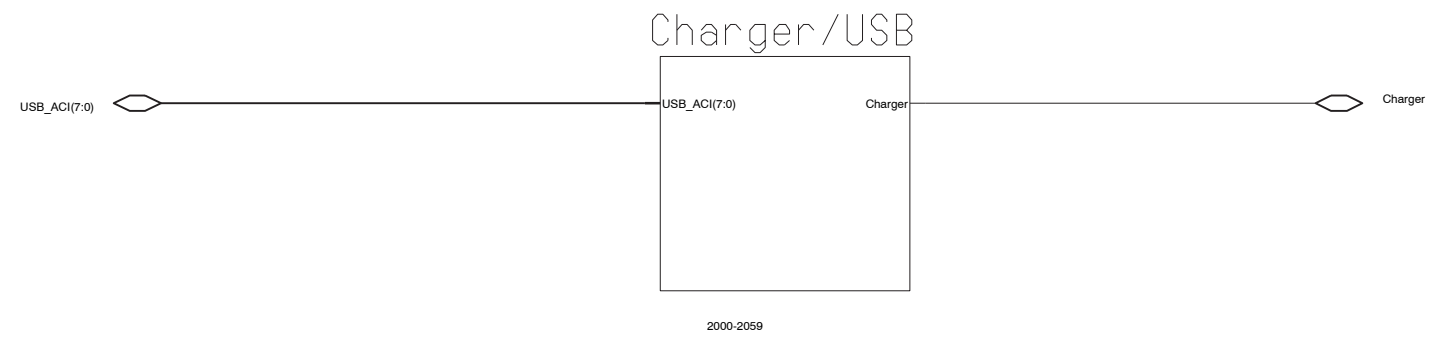

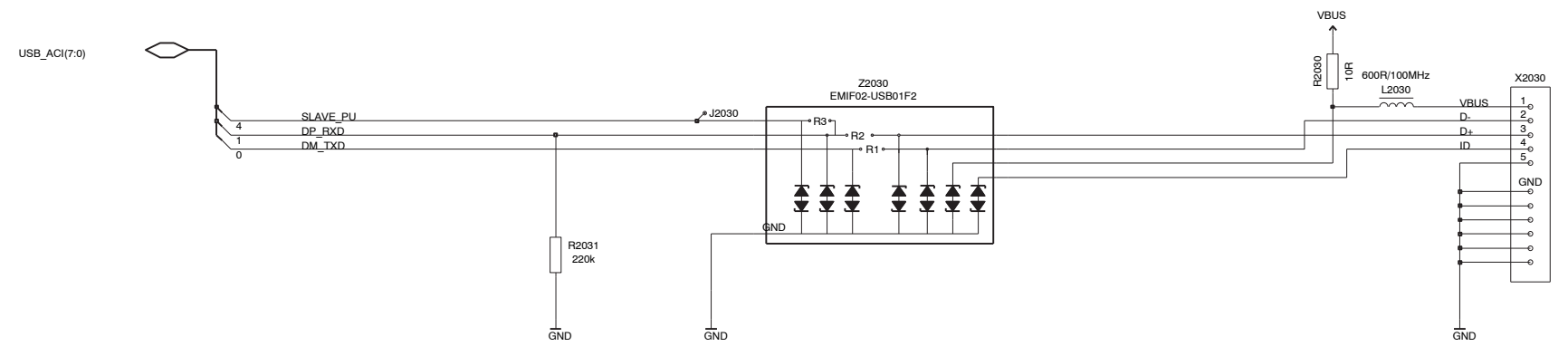
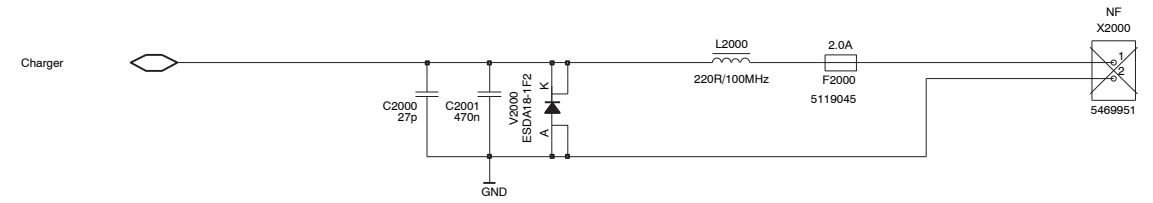

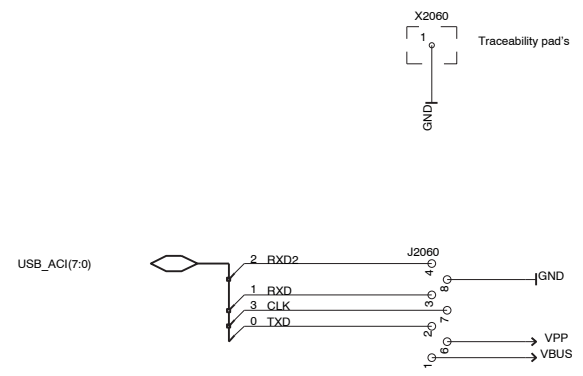

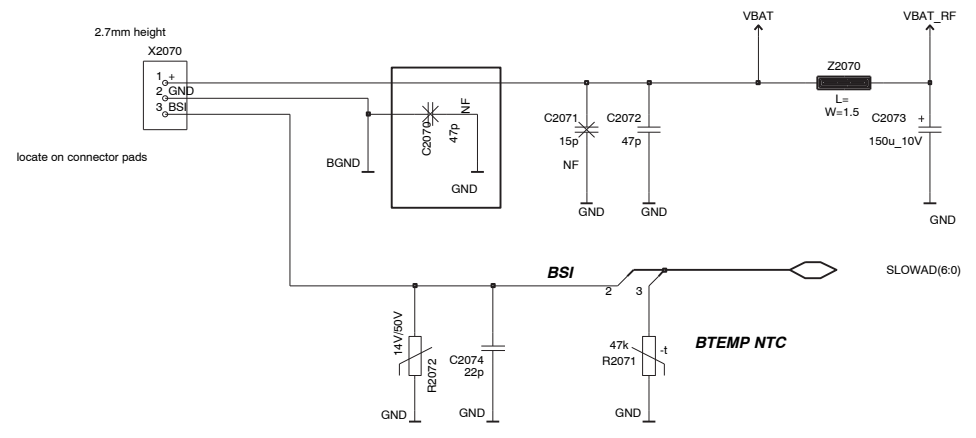

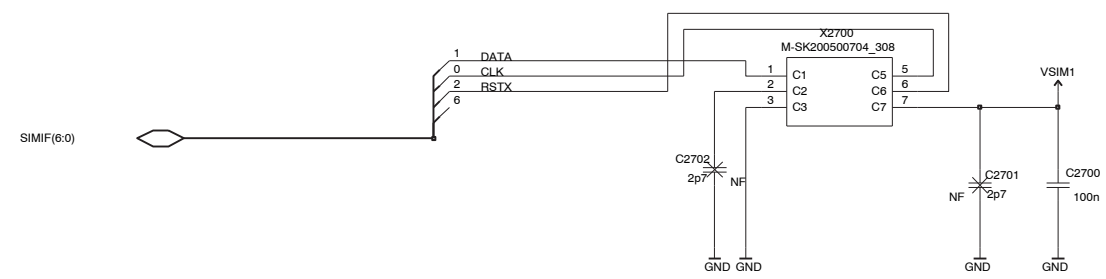

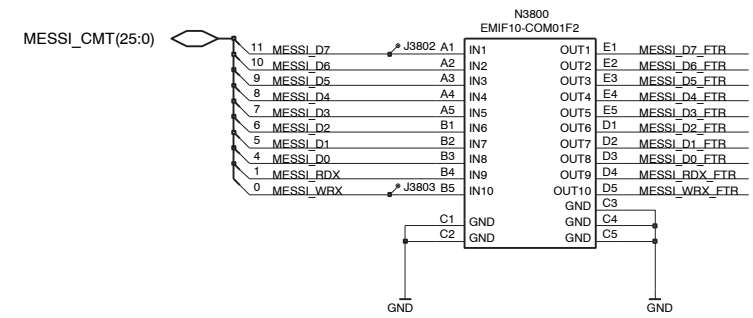
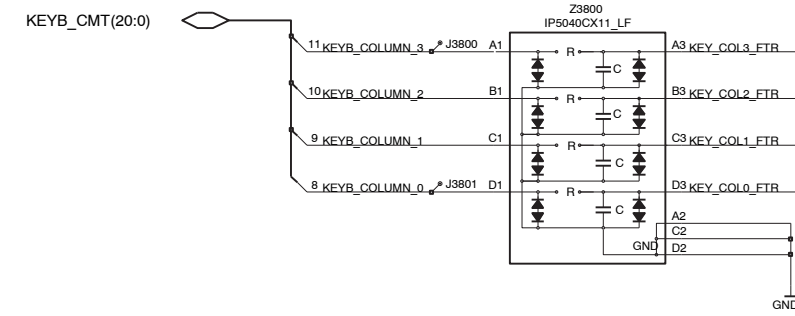
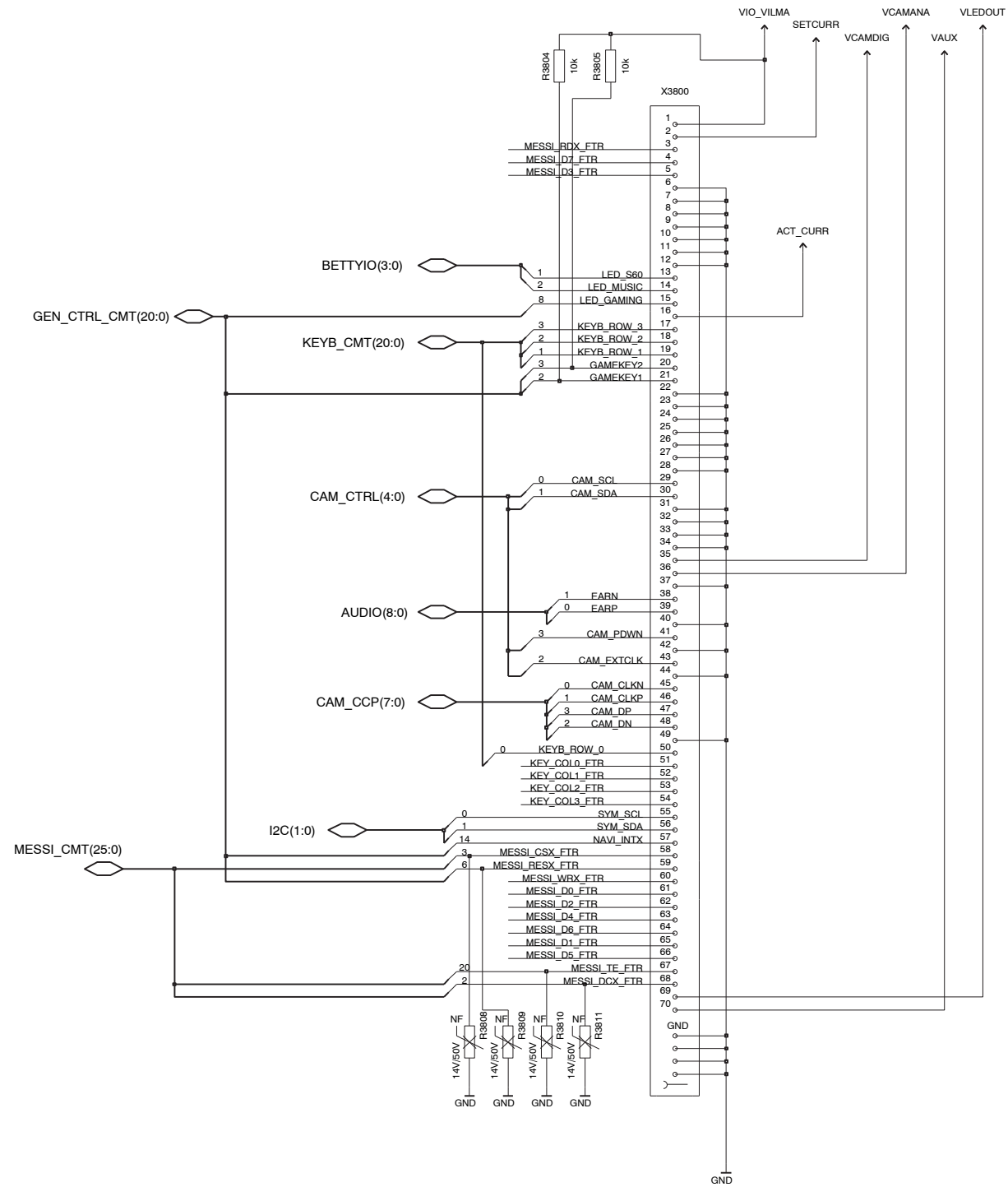

Activity LED Driver

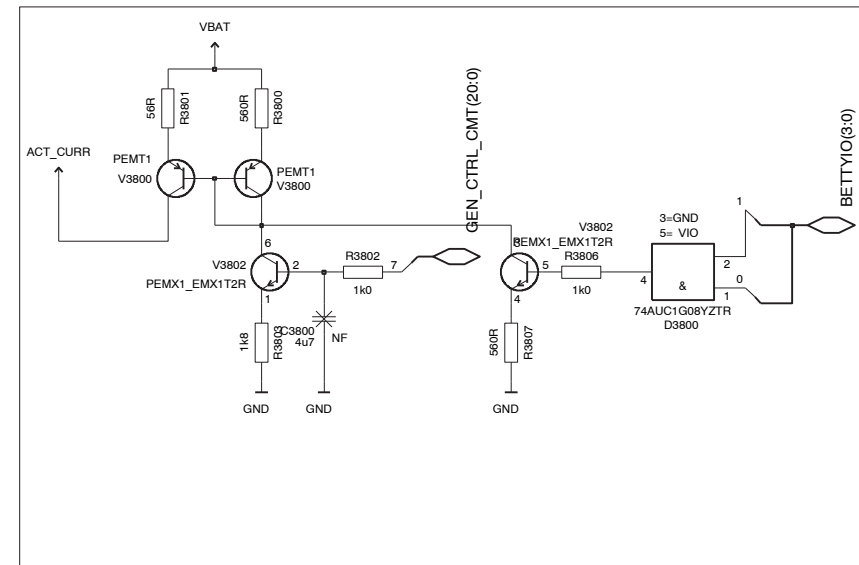

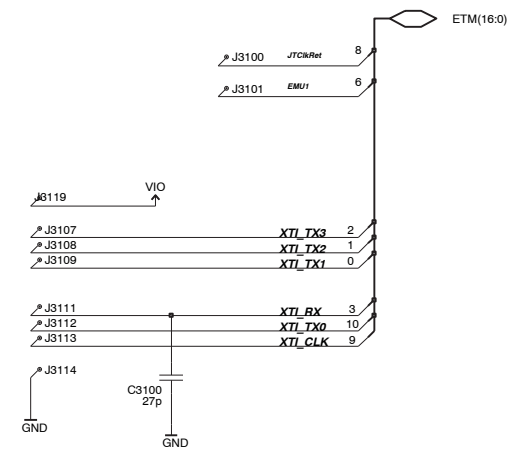
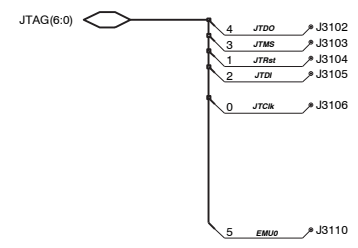

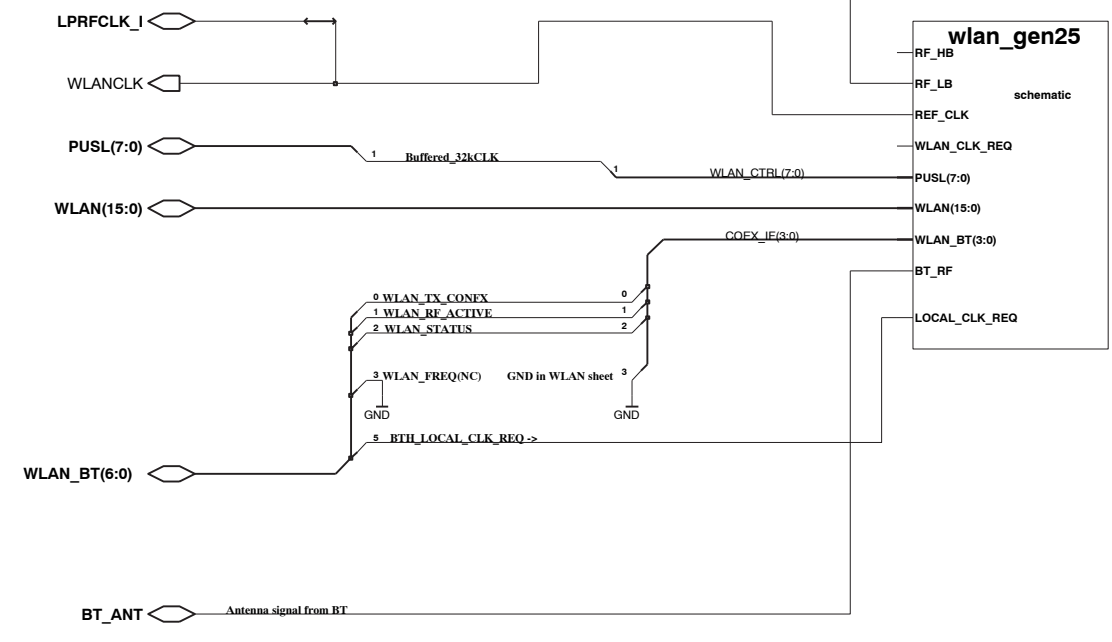
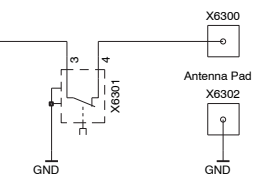
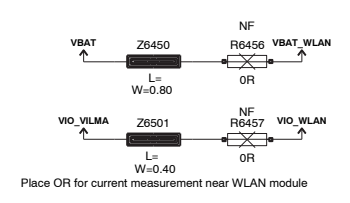

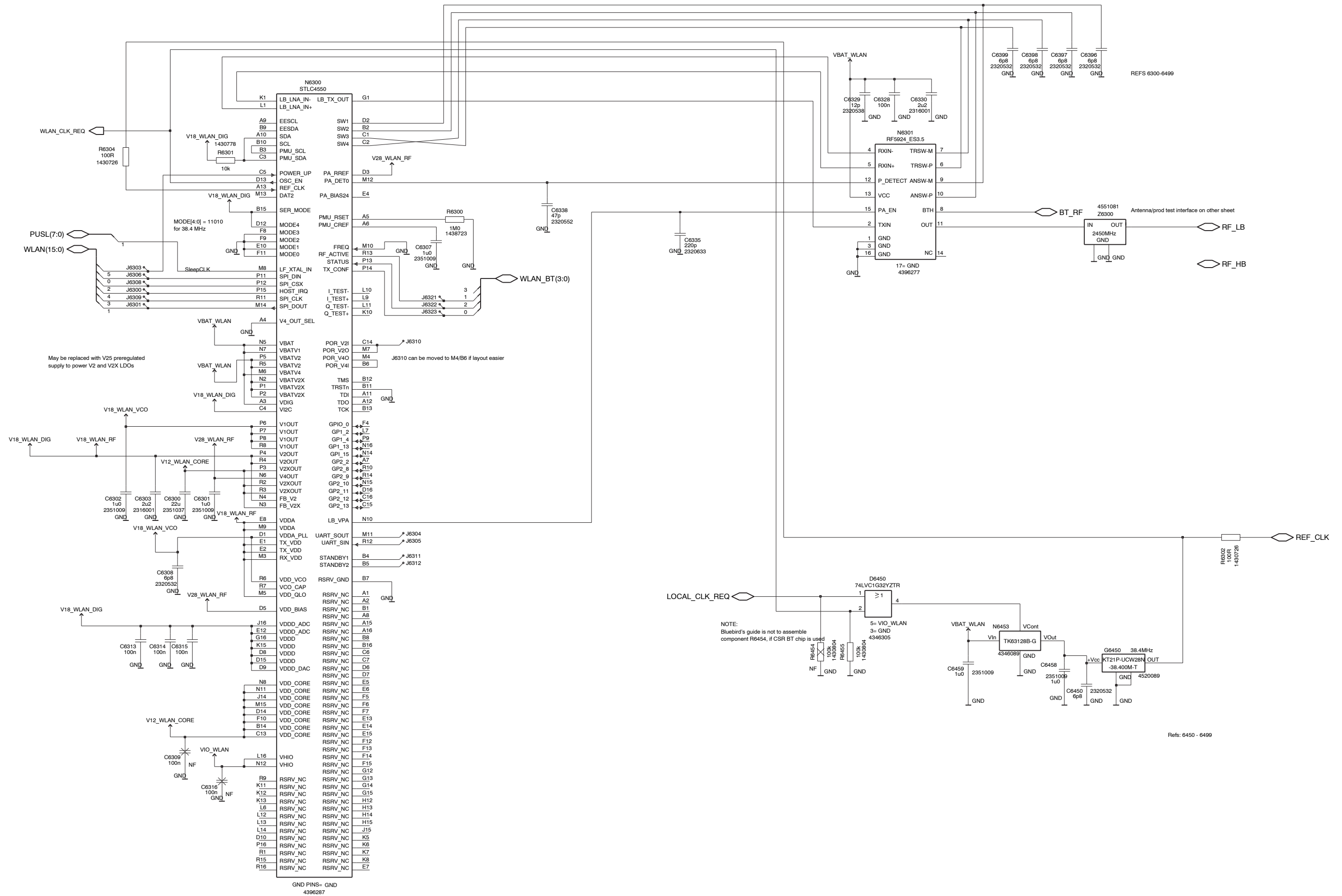

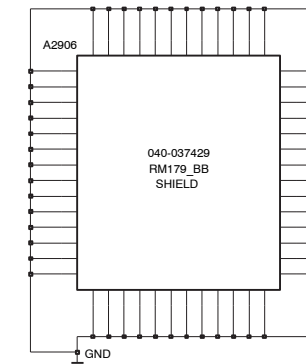
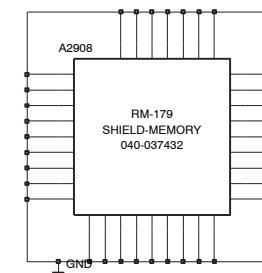
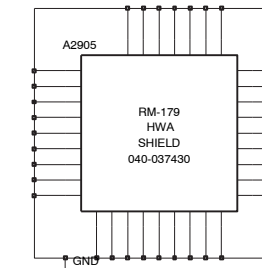
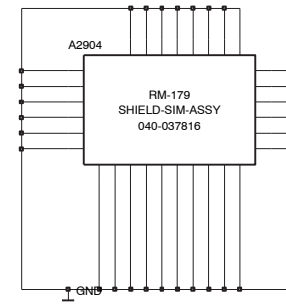
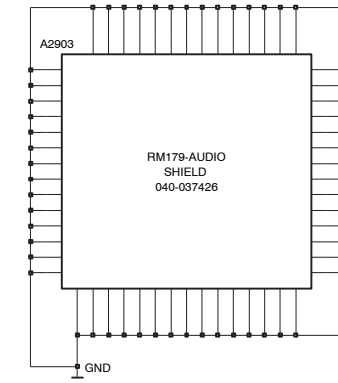
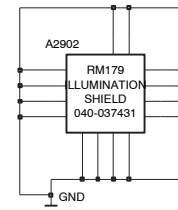
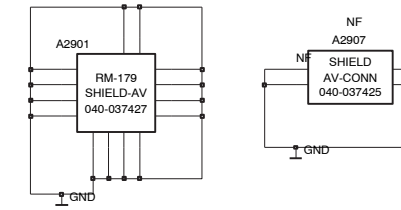
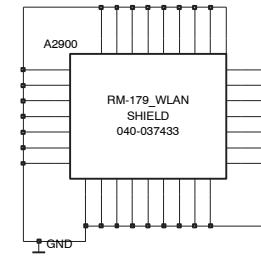

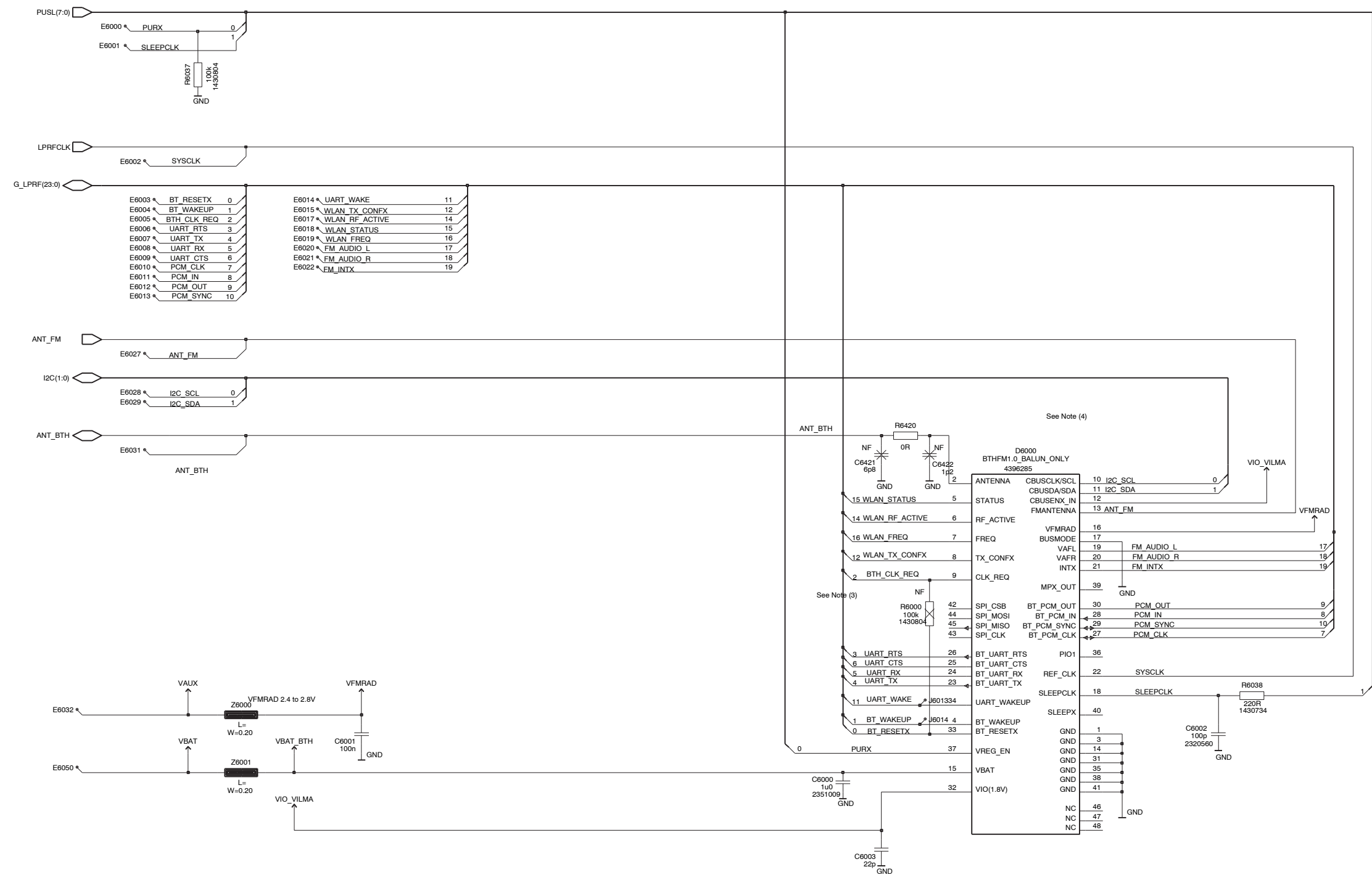

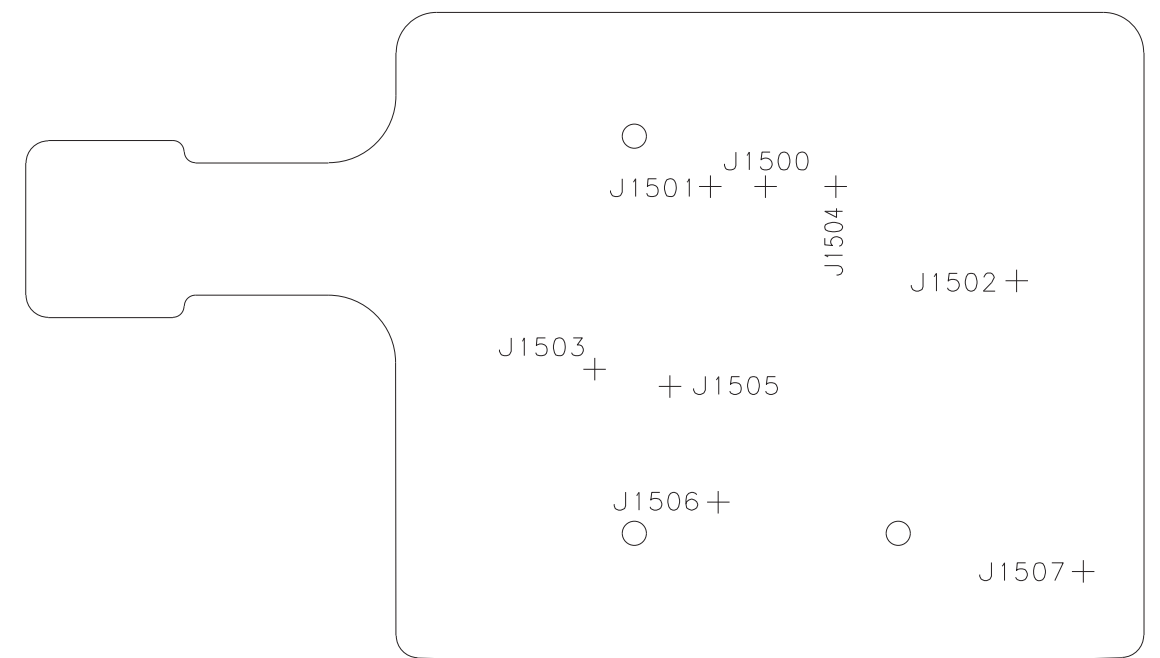
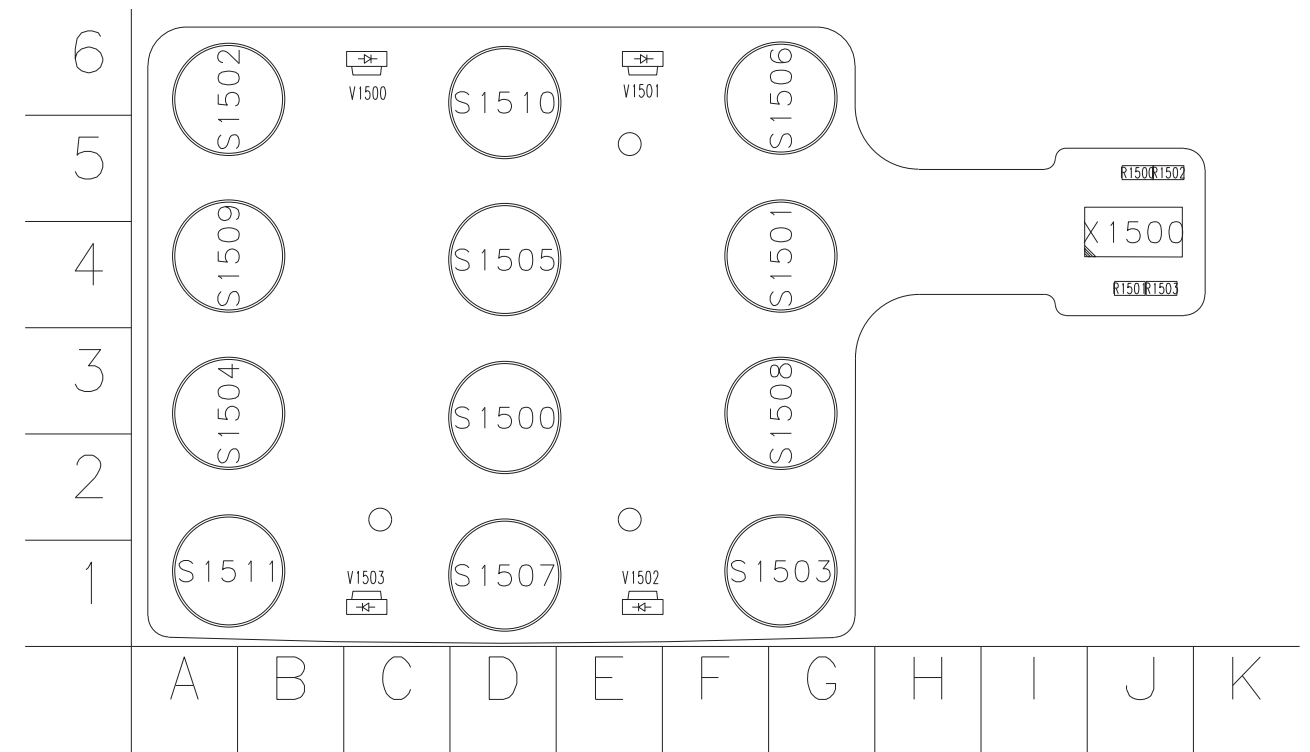
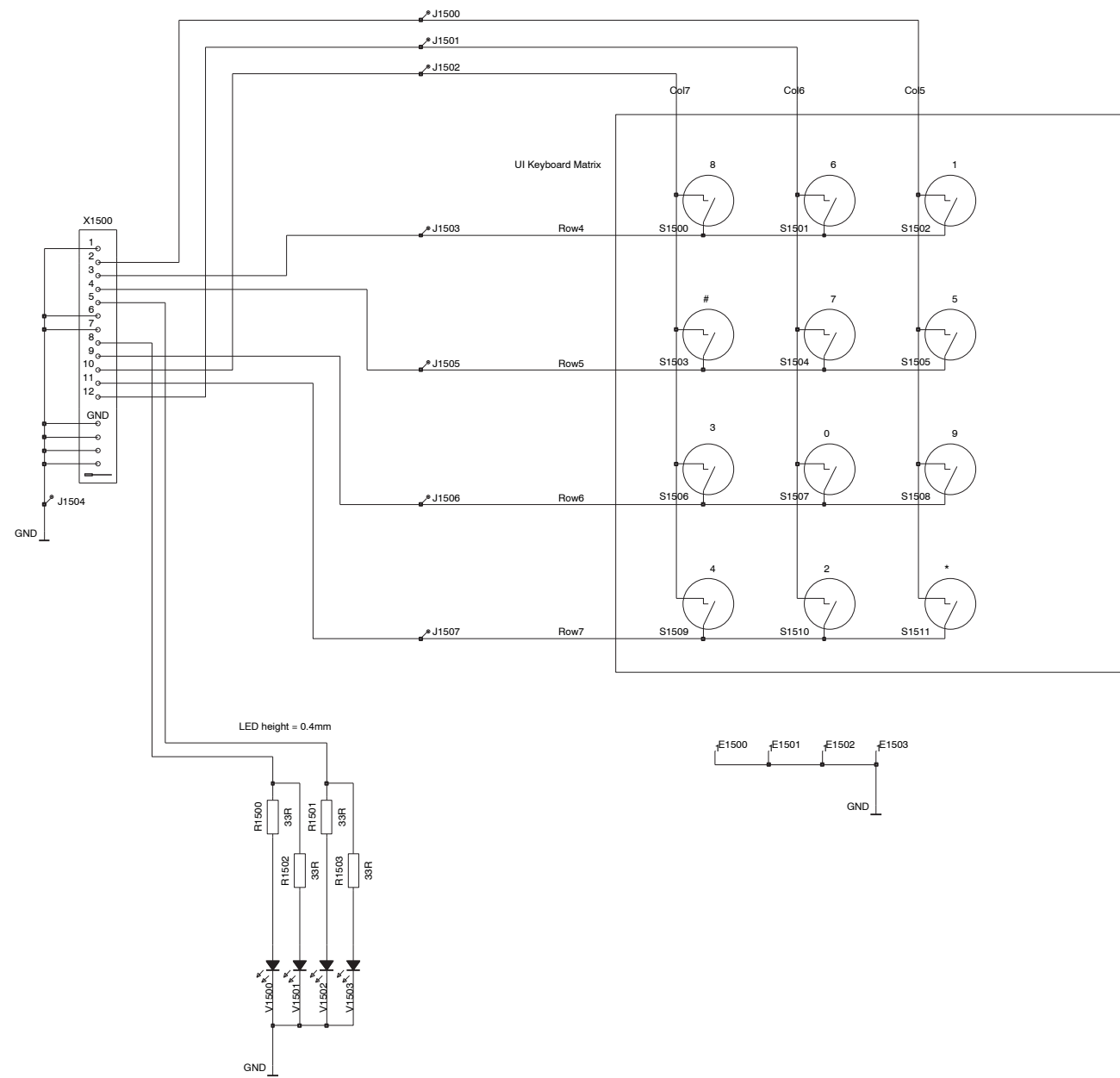

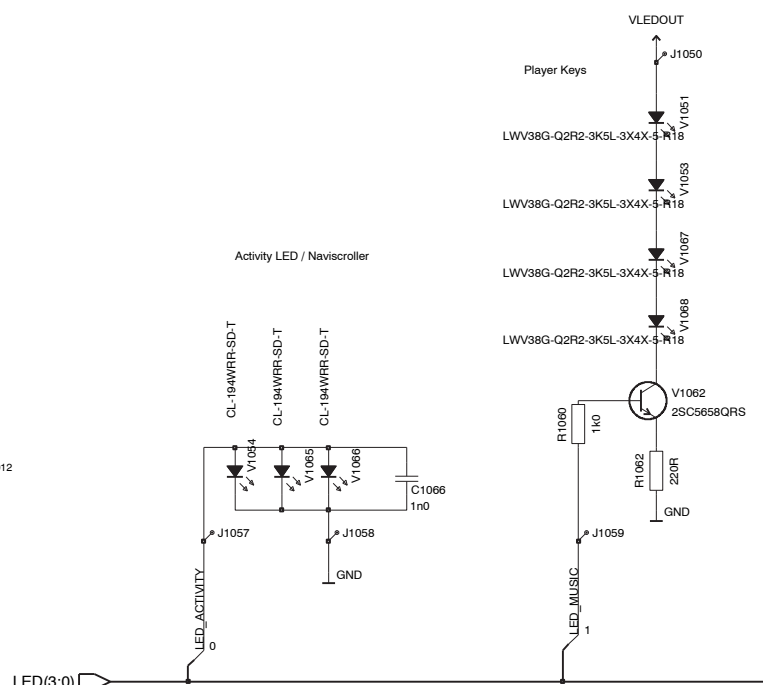
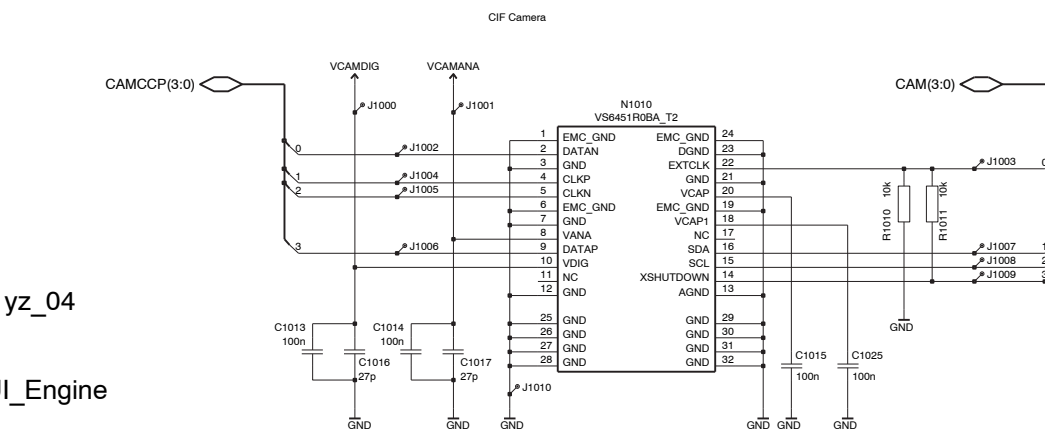
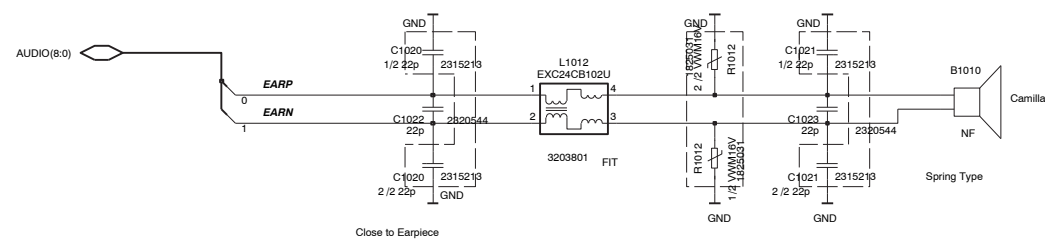
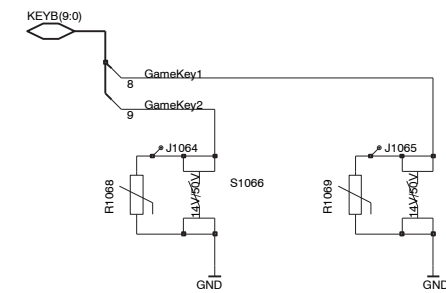
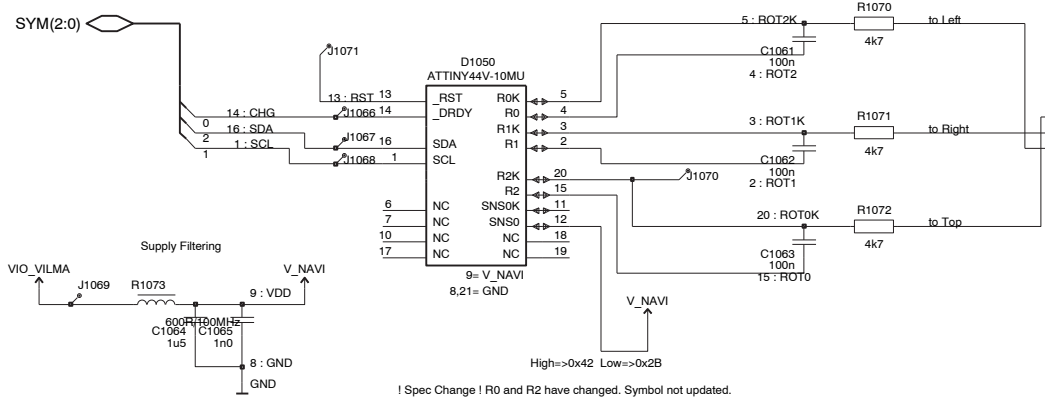
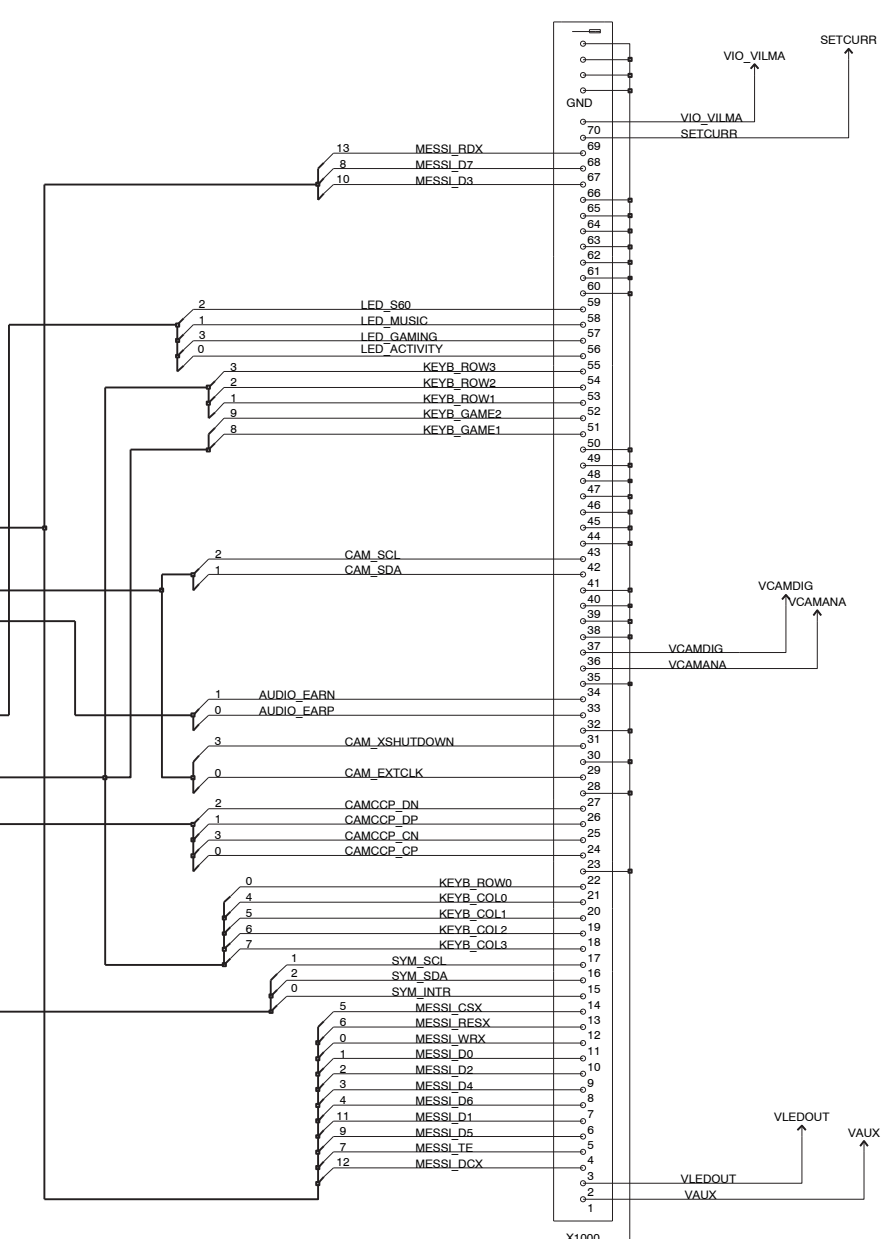
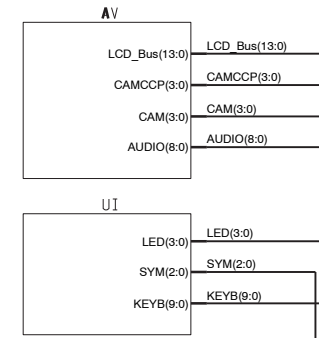
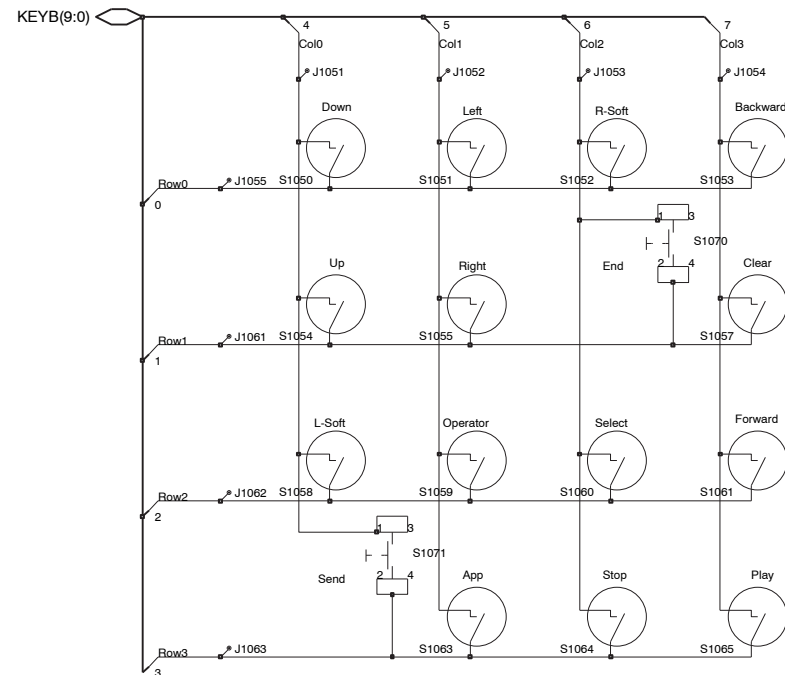
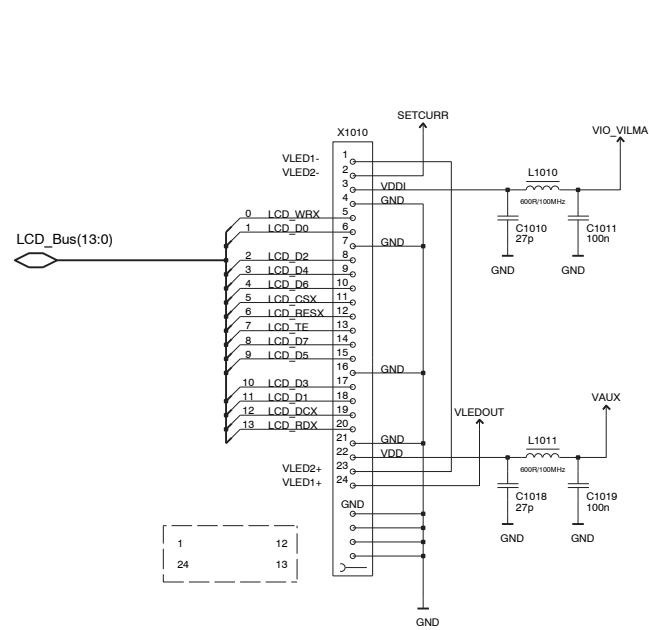

1yz_04
UI_Engine

24
23
22
21
20
19
18
17
16
15
14
13
12
11
10
9
8
7
6
5
4
3
2
1

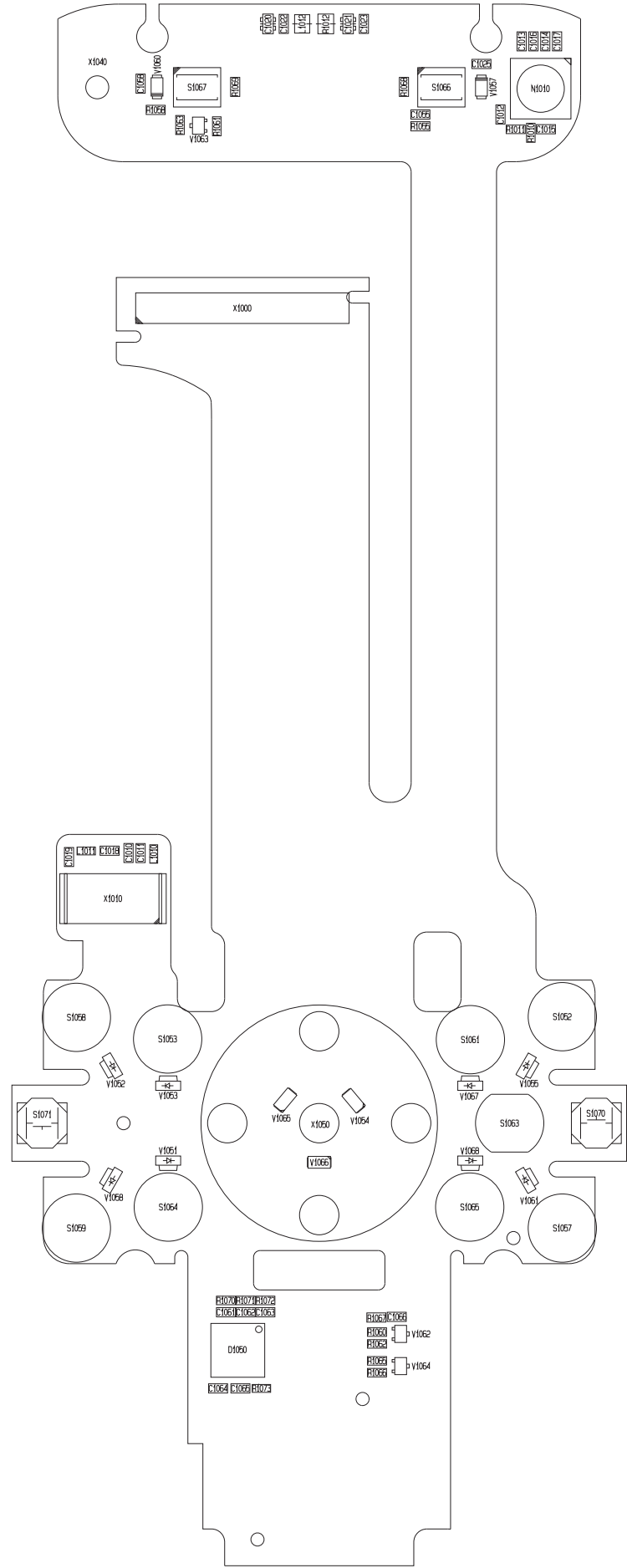

1yz_04a_asmdrw_t.pdf

A | B | C | D | E | F | G | H | I | J | K | L

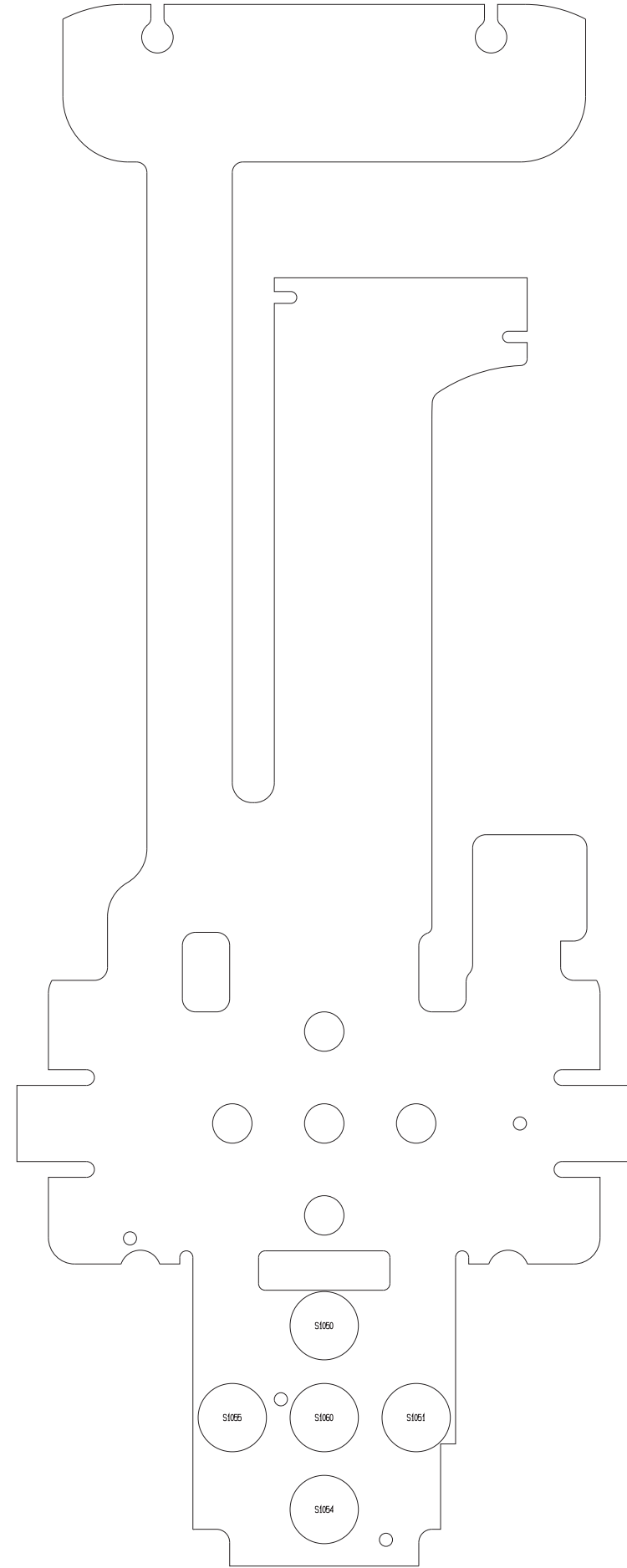

1yz_04a_asmdrw_b.pdf

L | K | J | I | H | G | F | E | D | C | B | A

24
23
22
21
20
19
18
17
16
15
14
13
12
11
10
9
8
7
6
5
4
3
2
1