

Service Manual

Tuner

Tuner

ST-HD70

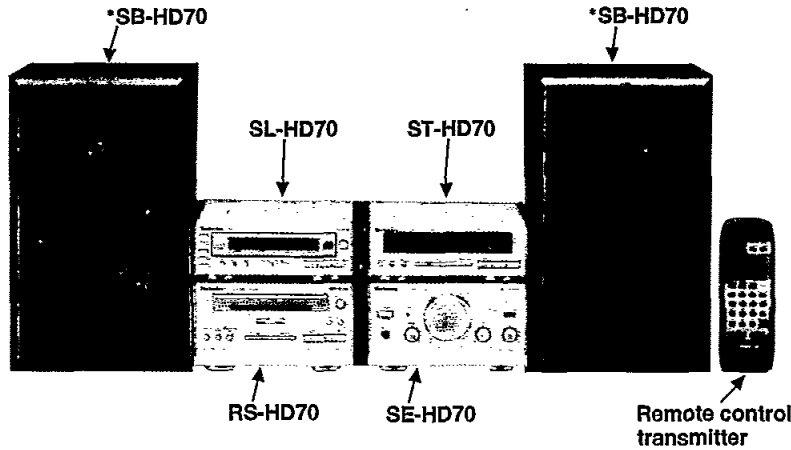

Colour

(N)Gold Type

Area

EEurope.

System: SC-HD70

Because of unique interconnecting cables, when a component requires service, send or bring in the entire system.

Specifications

Pre-amplifier section

Input sensitivity/Impedance

EXTERNAL: 250 mV/15 kΩ

Output level

EXTERNAL: 150 mV/1.5 kΩ

Frequency response

EXTERNAL: 50 Hz—25 kHz

S/N

EXTERNAL: DIN 82 dB (83 dB, IHF)

FM tuner section

Frequency range: 87.50—108.00 MHz (0.05 MHz steps)

Sensitivity: 1.8 μV (IHF usable)

S/N 26 dB: 1.5 μV

S/N

MONO: 70 dB (75 dB, IHF)

Stereo separation

1kHz: 35 dB

Antenna terminal(s): 75 Ω (unbalance)

AM tuner section

Frequency range: 522—1611 kHz (9 kHz steps) 530—1620 kHz (10 kHz steps)

Sensitivity (S/N 20 dB): 500 μV/m

Timer section

Clock: Quartz-lock type

Function: 24-hour programmable; Play timer (1 time), Rec timer (1 time) Sleep (120 min., 30 min. intervals)

Setting: 1 minute—23 hours 59 minutes (1 min. intervals)

General

Dimensions (W×H×D): 196(Wide)/ 67(High)/ 235(Depth) mm

Weight: 1.2 kg

Note:

Specifications are subject to change without notice.

Weight and dimensions are approximate.

System	Tuner	CD Player	Amplifier	Cassette deck	Speakers
SC-HD70	ST-HD70	SL-HD70	SE-HD70	RS-HD70	* SB-HD70

* Made in PAES

⚠ WARNING

This service information is designed for experienced repair technicians only and is not designed for use by the general public. It does not contain warnings or cautions to advise non-technical individuals of potential dangers in attempting to service a product. Products powered by electricity should be serviced or repaired only by experienced professional technicians. Any attempt to service or repair the product or products dealt with in this service information by anyone else could result in serious injury or death.

Technics®

© 1996 Matsushita Electric Industrial Co., Ltd.
All rights reserved. Unauthorized copying and distribution is a violation of law.

Contents

	Page
Location of Controls	2
Setting the Time.....	2
Preparing for the Remote Control.....	3
Installation.....	3
Connections.....	4~6
About the Self-Diagnostic Mode	7
Operation Checks and Main Component Replacement Procedures	8, 9
Wiring Connection Diagram	9
Block Diagram	10~13

	Page
To Supply Power Source	14
Replacement of the Foot.....	15
Schematic Diagram	15~23
Printed Circuit Board Diagram.....	24~26
Terminal Guide	27, 28
Resistors and Capacitors.....	29, 30
Replacement Parts List.....	31, 32, 34
Cabinet Parts Location	33
Packaging.....	34

NOTE:

Refer to the service manual for Model No. SE-HD70 (ORDER No. AD9610196A2) for information on "Accessories".

Location of Controls

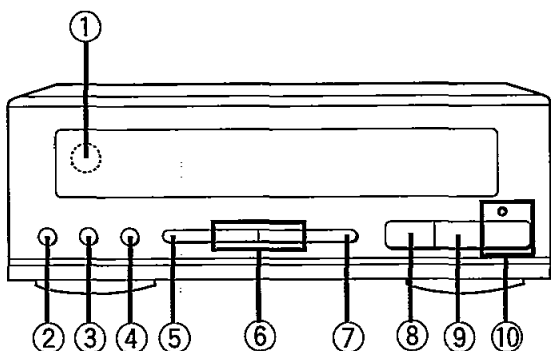

- ① Remote control signal sensor (SENSOR)
- ② Record timer button (Ⓜ REC)
- ③ Play timer button (Ⓜ PLAY)
- ④ Clock/timer button (CLOCK/TIMER)
- ⑤ Set button (SET)
- ⑥ Tuning/time adjust buttons
(V, ^ TUNING/TIME ADJUST)
- ⑦ Tuning mode select button (TUNING MODE)
- ⑧ Source input select button (INPUT SELECTOR)
- ⑨ RDS display mode select button
(RDS DISPLAY MODE)
- ⑩ Band select button and indicator (TUNER FM/AM)

Setting the time

The tuner displays the time, frequency and other information on CDs and tapes.

This is a 24-hours display clock.

These instructions explain how to set the timer for 16:25 on Wednesday.

1 Switch on the power.

2 ① Press CLOCK/TIMER to show "CLOCK".

Within 8 seconds:

Every time you press the button, the indication changes in the order of CLOCK → Ⓜ REC → Ⓜ PLAY → Original display.

② Press SET.

3 ① Press V or ^ to select the day.

Every time you press one of the buttons, the indication changes in the order of SUN ↔ MON ↔ TUE ↔ WED ↔ THU ↔ FRI ↔ SAT.

② Press SET.

4 ① Press V or ^ to select the hour.

② Press SET.

5 ① Press V or ^ to select the minutes.

② Press SET to finish setting the time.

The display will return to the previous display after about 4 seconds.

When " —:—" appears:

If flashes when you connect the AC power supply cord for the first time or if there has been a power failure.

Reset the time as explained above.

If the minutes setting has gone wrong:

1. Press CLOCK/TIMER.
2. Press SET 3 times.
3. Press V or ^ to set the minutes, and then press SET.

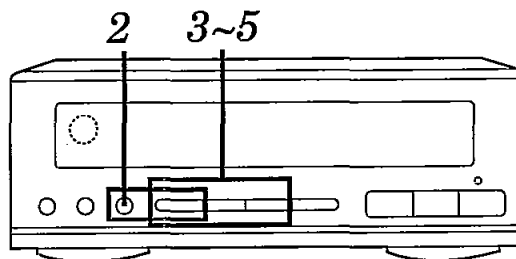
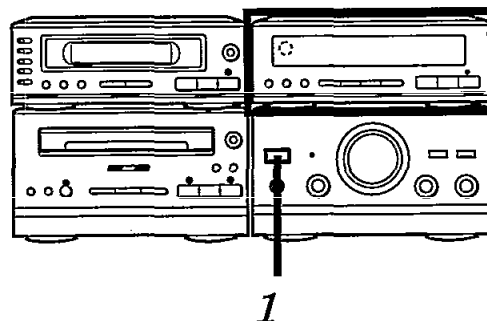

To display the clock again:

Press CLOCK/TIMER.

The clock display will appear for about 8 seconds.

For your reference:

When you turn OFF the system from the POWER button, the system goes on standby and the STANDBY indicator lights up.

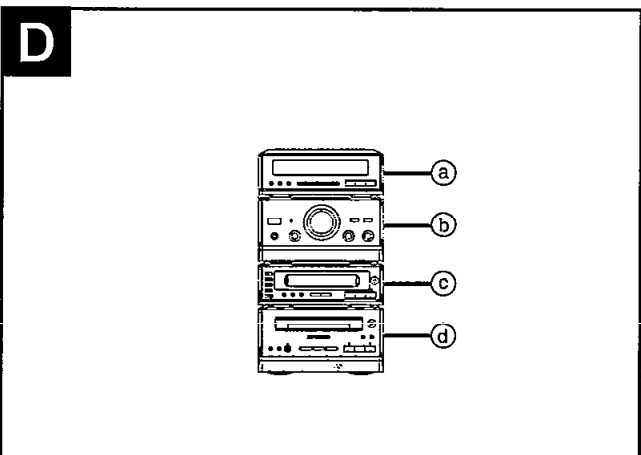
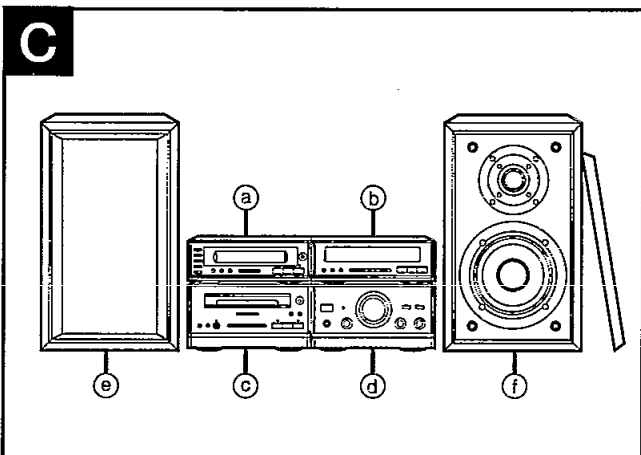
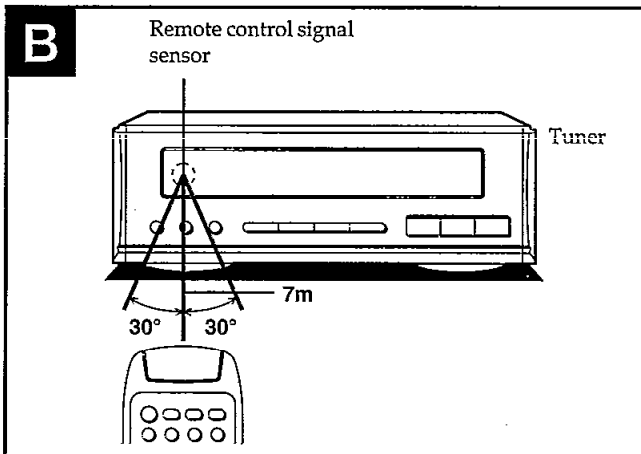
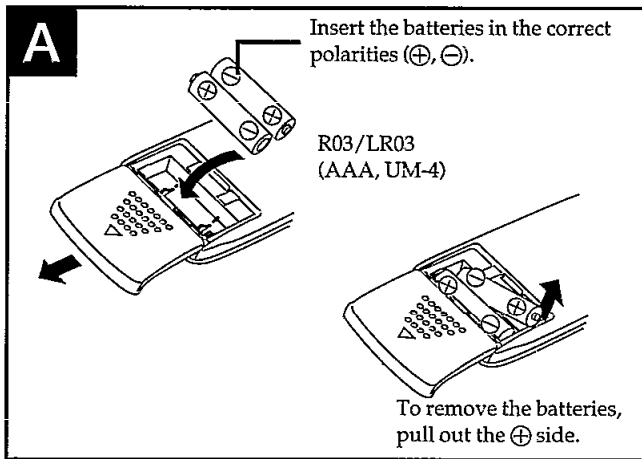

■ Preparing for the Remote Control

Battery installation **A**

- Do not mix old and new batteries, or batteries of different types (manganese and alkaline, etc.).
- Never subject batteries to excessive heat or flame; do not attempt to disassemble them; and be sure they are not short-circuited.
- If the remote control is not to be used for a long period of time, remove the batteries and store them in a cool, dark place.
- Do not attempt to recharge alkaline or manganese batteries.
- Do not use rechargeable type batteries.

The battery life is about one year.

The batteries should be replaced if commands from the remote control transmitter do not operate the unit even when the transmitter is held close to the front panel.

Correct method of use **B**

- Aim the remote control's transmission window toward the unit's sensor. Avoid any obstacles.
- The maximum distance is within 7 meters directly facing toward the remote control signal sensor.
- Be sure the transmission window and the unit's sensor are free from dust. Excessive dust might affect its performance.
- The operation may not be correct if direct sunlight or other strong light source strikes the receiving sensor of this unit. If there is a problem, place the unit away from the light source.
- If this system is installed in a rack with glass doors, the glass doors' thickness or color might make it necessary to use the remote control a shorter distance from the system.
- Never place heavy items.
- Do not disassemble or reconstruct.
- Do not spill water or other liquids.

■ Installation

Locating the components

Side-by-side set-up **C**

- a CD changer (SL-HD70)
- b Tuner (ST-HD70)
- c Cassette deck (RS-HD70)
- d Amplifier (SE-HD70 or SE-HD65)
- e Left speaker (SB-HD70 or SB-HD50A)
- f Right speaker (SB-HD70 or SB-HD50A)

Stacking **D**

- a Tuner (ST-HD70)
- b Amplifier (SE-HD70 or SE-HD65)
- c CD changer (SL-HD70)
- d Cassette deck (RS-HD70)

Caution

Use the speakers only with the recommended system. Failure to do so may lead to damage to the amplifier and/or the speaker, and may result in the risk of fire. Consult a qualified service person if damage has occurred or if you experience a sudden change in performance.

Note

Left and right speakers are exactly the same.

Connections

Connect the AC mains lead after you have connected all other cables.

To prepare the AM loop antenna wire and speaker cords, twist the vinyl cover tip and pull off.

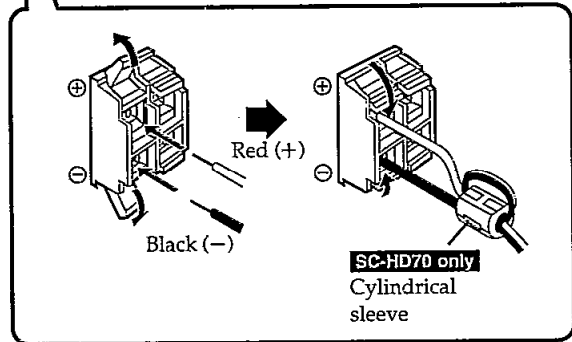
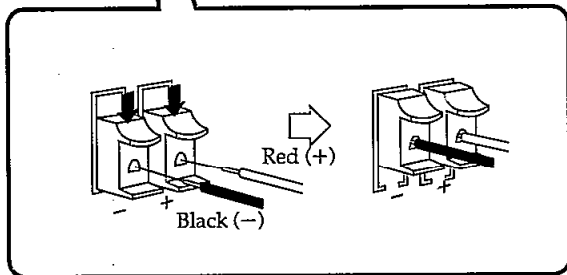
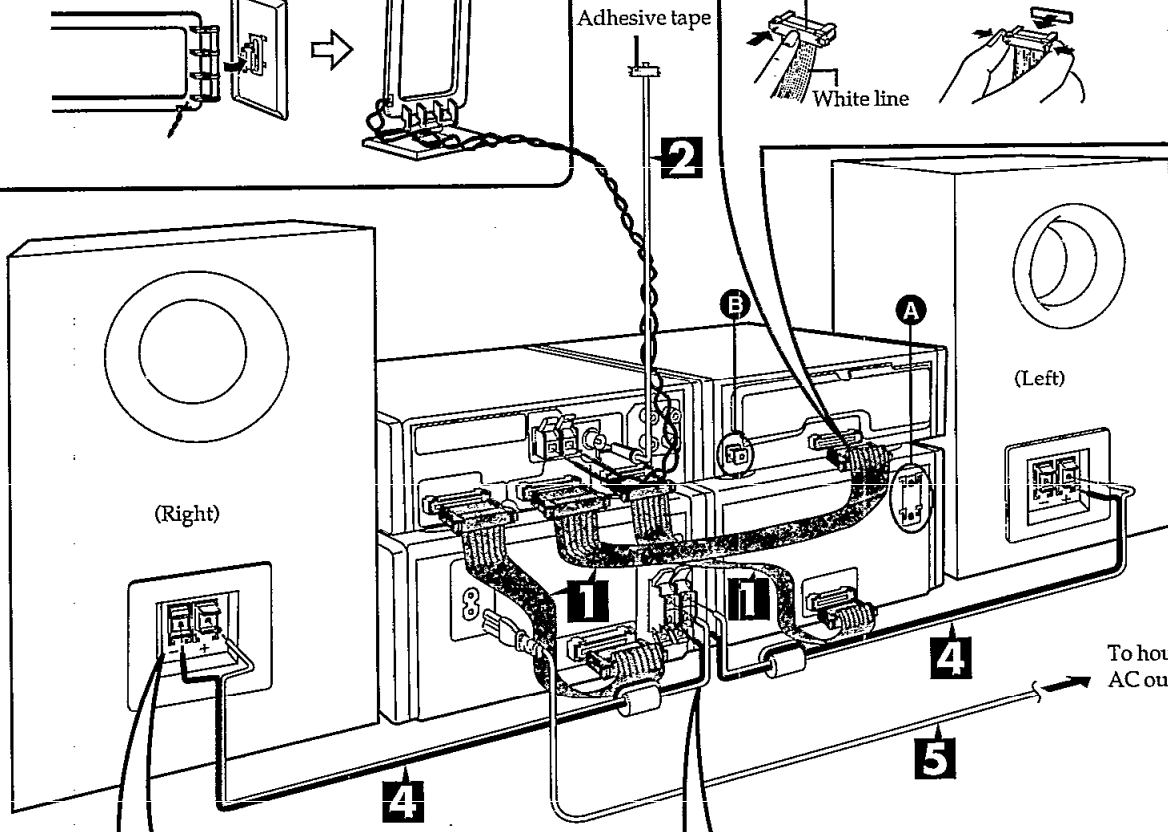
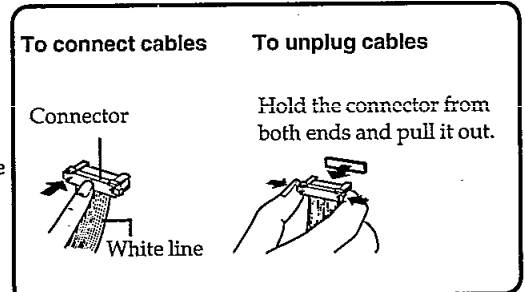
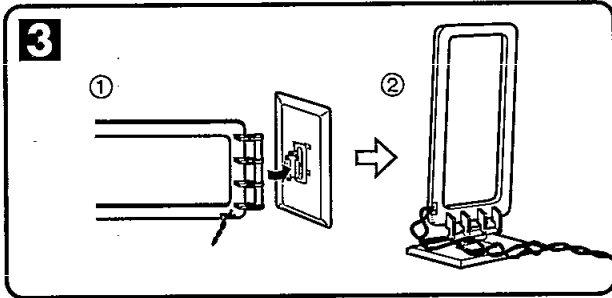
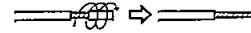

1 Connect the flat cables.

1. Connect the short flat cable to the terminal of the A1 and A2.
2. Connect the long thick flat cable to the terminal of the B1 and B2.
3. Connect the long thin flat cable to the terminal of the C1 and C2.

Note

Do not try connecting or disconnecting the flat cables while the power is switched to ON.

After connection:

Keep cables as flat against the back of the unit as possible.

2 Connect the FM indoor antenna.

Tape the antenna to a wall or column, in a position where radio signals are received with the least amount of interference.

Note

When you cannot get a good reception with this FM indoor antenna, we recommend you install an FM outdoor antenna (not included).

3 Connect the AM loop antenna.

You can also install the AM loop antenna on the rear of the cassette deck, wall or pillars.

In this case, be sure to use the antenna holder with the hole.

- To install on the cassette deck rear (A)

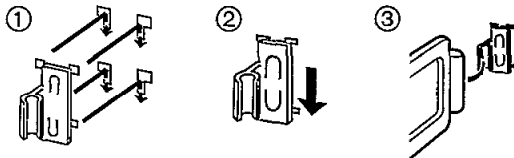

- To install on walls or pillars

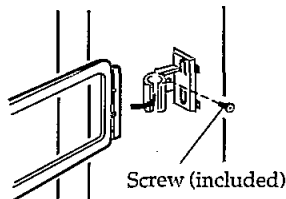
**Note**

To minimize noise pickup, bundle the loop antenna cord using a tape or so to keep the flat cables away from the AM loop antenna cord.

4 Connect the right (R) and left (L) front speaker cables.**Note**

- For SC-HD70 connect the end of the speaker cable with the cylindrical sleeve to the amp side.
- To prevent damage to circuitry, never short-circuit positive (+) and negative (-) speaker wires.
- Be sure to connect only positive (red) wires to positive (+) terminals and negative (black) wires to negative (-) terminals.

These speakers are made so as to be able to be used in close proximity to the TV, but irregular coloring may result due to how the system is placed. If such distortion occurs, turn off the TV for sometime between 15 and 30 minutes. The demagnetizing function of the TV will eliminate the distortion. If the irregular coloring is still visible, then move the speaker further away from the TV. Please note that if there is a magnetic object near the TV, irregular coloring may result due to the interaction between the TV and the speakers.

5 Connect the AC mains lead.

(United Kingdom only)

BE SURE TO READ THE CAUTION FOR AC MAINS LEAD ON PAGE 4 BEFORE PROCEEDING TO STEP 5.

Insertion of Connector

Even when the connector is perfectly inserted, depending on the type of inlet used, the front part of the connector may jut out as shown in the drawing.

However there is no problem using the unit.

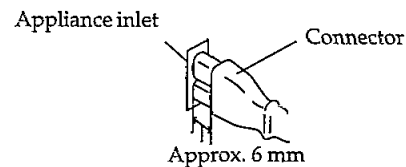
**Connections to "DIGITAL OPTICAL OUT" terminal: (B)**

Before using this terminal, take out the dust protection cap.

Connect an optical-fiber cable to the optical input terminal of the DCC or minidisc deck (cables and components not included).

Optional antenna connections

You may need an outdoor antenna if you use this system in a mountainous region or inside a reinforced-concrete building, etc.

FM outdoor antenna (not included) 

Note

An outdoor antenna should be installed by a competent technician only.

AM outdoor antenna (not included) 

Connect the outdoor antenna without removing the AM loop antenna. Run 5 to 12 m of vinyl-covered wire horizontally along a window or other convenient location.

Note

When the unit is not in use, disconnect the outdoor antenna to prevent possible damage that may be caused by lightning. Never use an outdoor antenna during an electrical storm.

External unit connections

Connecting a cassette deck 

- Make sure that the power supply for all components has been turned off before making any connections.
- For details, refer to the operating instructions of the cassette deck which is to be connected.
- All peripheral components and cables sold separately.

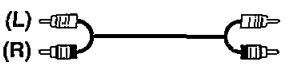
Stereo connection cable
 White (L) 
 Red (R)

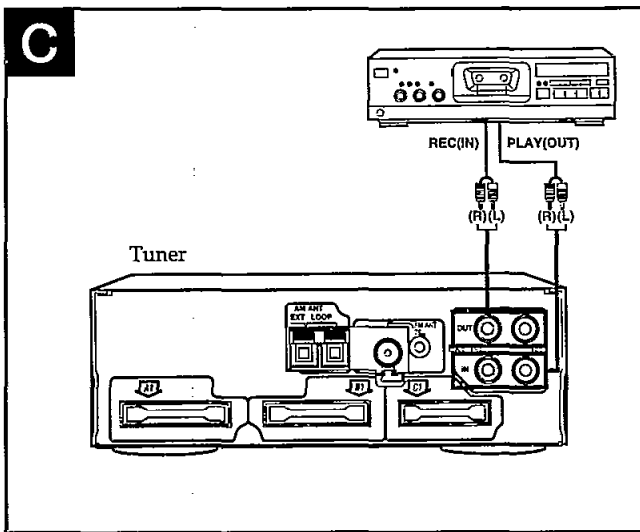
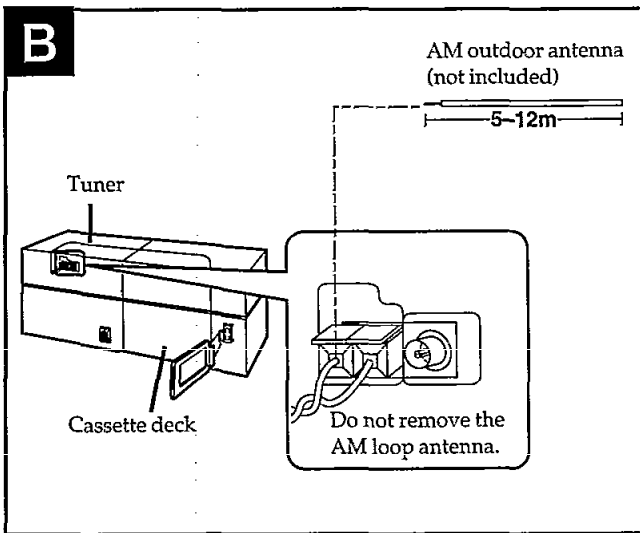
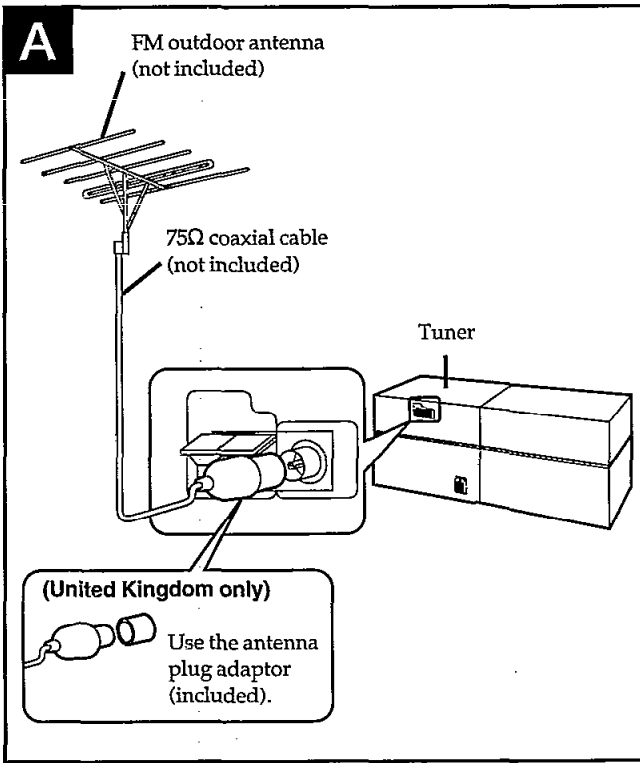

About the Self-Diagnostic Mode

This unit is equipped with a self-diagnostic function which, in the event of a malfunction, automatically displays a code indicating the nature of the malfunctions. Use this self-diagnostic function when servicing the unit.

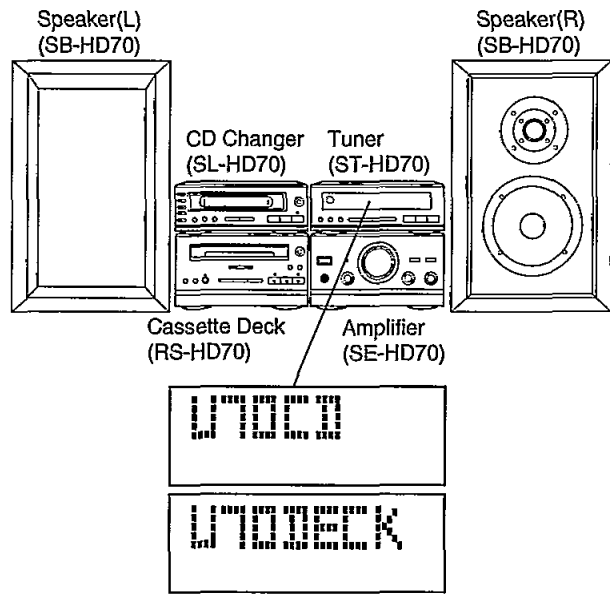
Display method	Display location
<p>To display the malfunction code</p> <p>U70 CD: U70 DECK:..... Automatically displays on the tuner when a malfunction occurs.</p> <p>F61 Automatically displays on the tuner when a malfunction occurs.</p> <p>To return to the normal display</p> <p>1. For U70 CD/U70 DECK:</p> <ul style="list-style-type: none"> ● Press any operation button on the tuner. ● To re-display the code, switch the power off (POWER STANDBY button), and then switch power back on again. <p>2. For F61:</p> <ul style="list-style-type: none"> ● If "F61" is displayed, the power will automatically be switched off and the standby indicator will light up. ● "F61" will be displayed for 3 seconds, and then the clock will be displayed. ● To re-display the code, switch the power on. "F61" will be re-displayed, and then after 3 seconds the clock will be displayed and the power will automatically switch off. 	

Display contents

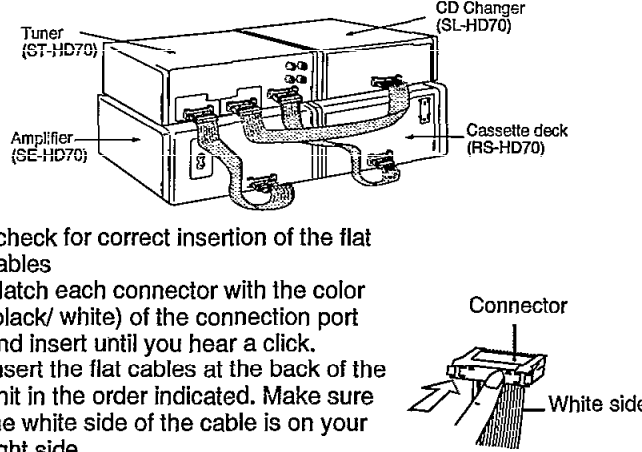
Display code	Problem or condition	Correction procedure
<p>U70 CD U70 DECK (displayed automatically)</p>	<p>A bus-line communications error has occurred as a result of the flat cables being inserted incorrectly, thus preventing the system from operating.</p> <p>1. If "U70" is displayed on the tuner, the Cassette deck or CD changer cannot be operated by remote control.</p>	 <p>1. To check for correct insertion of the flat cables</p> <ol style="list-style-type: none"> ① Match each connector with the color (black/ white) of the connection port and insert until you hear a click. ② Insert the flat cables at the back of the unit in the order indicated. Make sure the white side of the cable is on your right side. <p>2. Breakage of flat cable (Check and replace as necessary.)</p> <p>3. If the problem is not corrected by items (1.) and (2.) above, this indicates a faulty IC.</p> <p>ST-HD70: IC901 (M38198MC092F)</p> <p>SL-HD70: IC301 (LC66538A4J35)</p> <p>RS-HD70: IC701 (M37471M4264F)</p> <p>Check these IC's and replace as necessary.</p>
<p>F61</p>	<p>When the power switch is switched on, it automatically switches back off, making it impossible to switch power on.</p>	<ul style="list-style-type: none"> ● Faulty amplifier (SE-HD70) output IC (IC505, 506). (When a DC voltage is applied to the speaker terminals.)

Operation Checks and Main Component Replacement Procedures

- NOTE**
1. This section describes procedures for checking the operation of the major printed circuit boards and replacing the main components.
 2. For reassembly after operation checks or replacement, reverse the respective procedures. Special reassembly procedures are described only when required.

1. Checking for the RDS P.C.B., tuner P.C.B. and FL P.C.B.

Step 2

Remove the side panel (L),(R).

- Spread the lower part of the side panels in the direction of arrow (→①) to release the ribs, and then lift to remove the side panels (→②).

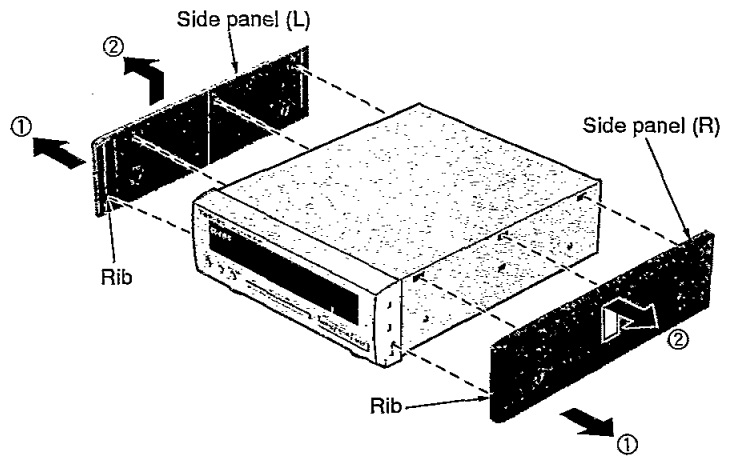
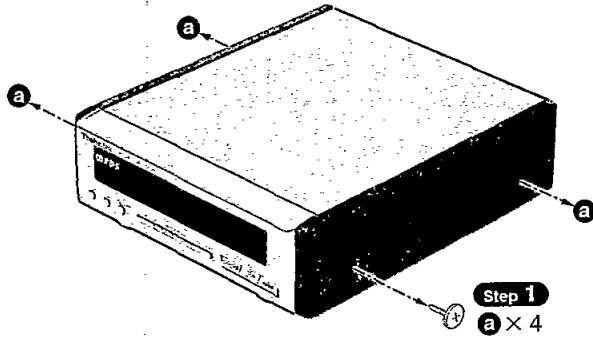

Step 4
Remove the cabinet.

Step 3

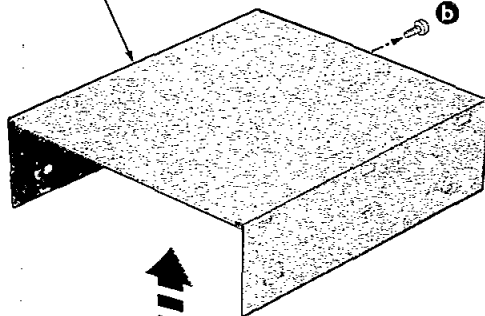

- Check the RDS P.C.B., tuner P.C.B. and FL P.C.B. as shown below.

Step 6

Pull out the front panel ass'y.

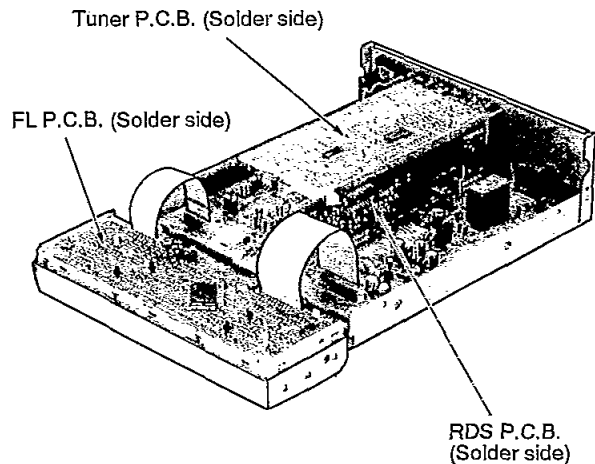
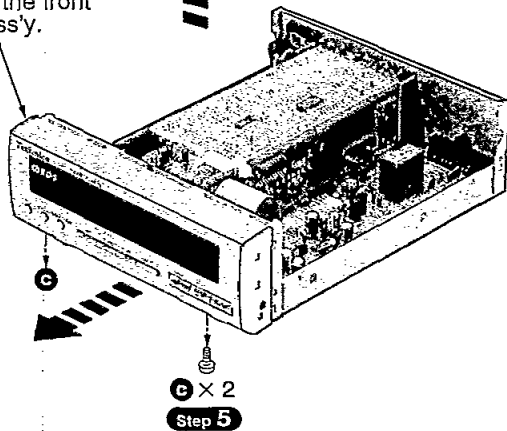

2. Checking for the main P.C.B.

• Follow **Step 1** ~ **Step 6** in Item 1 on page 8.

• Check the main P.C.B. as shown below.

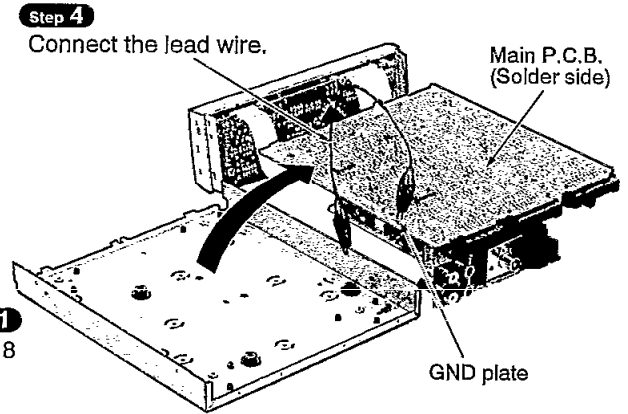
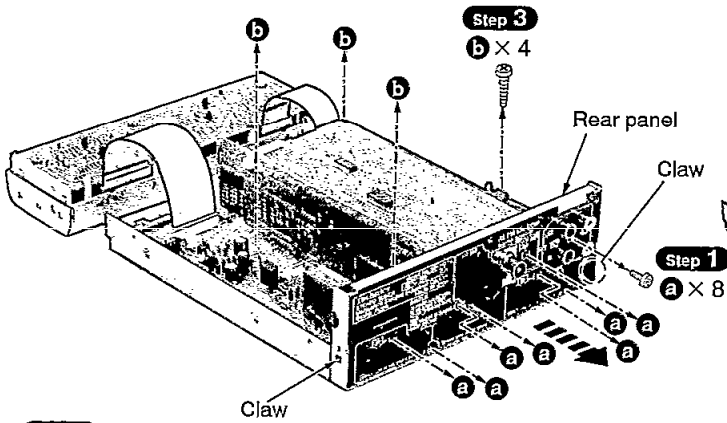

Step 2

Release the 2 claws, and then remove the rear panel.

■ Wiring Connection Diagram

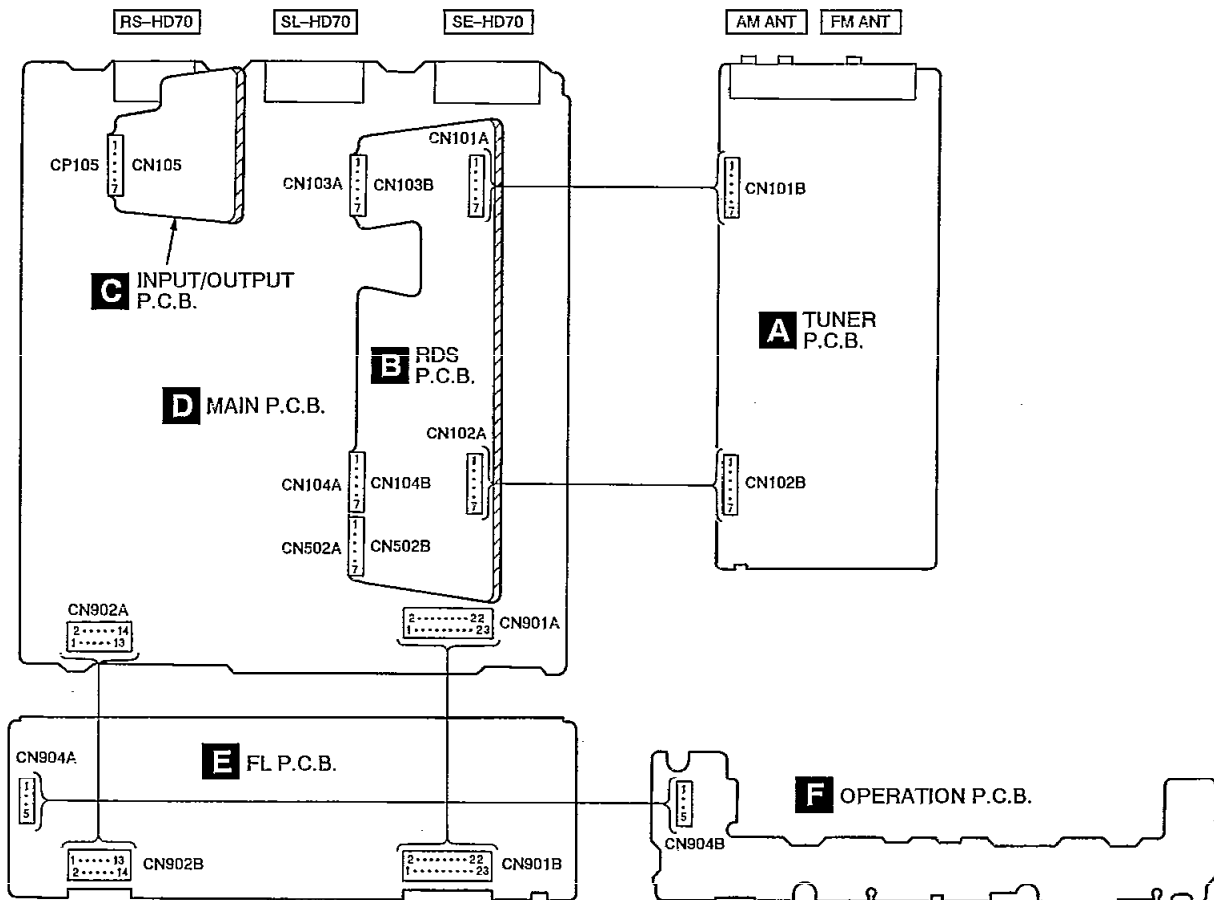

Block Diagram

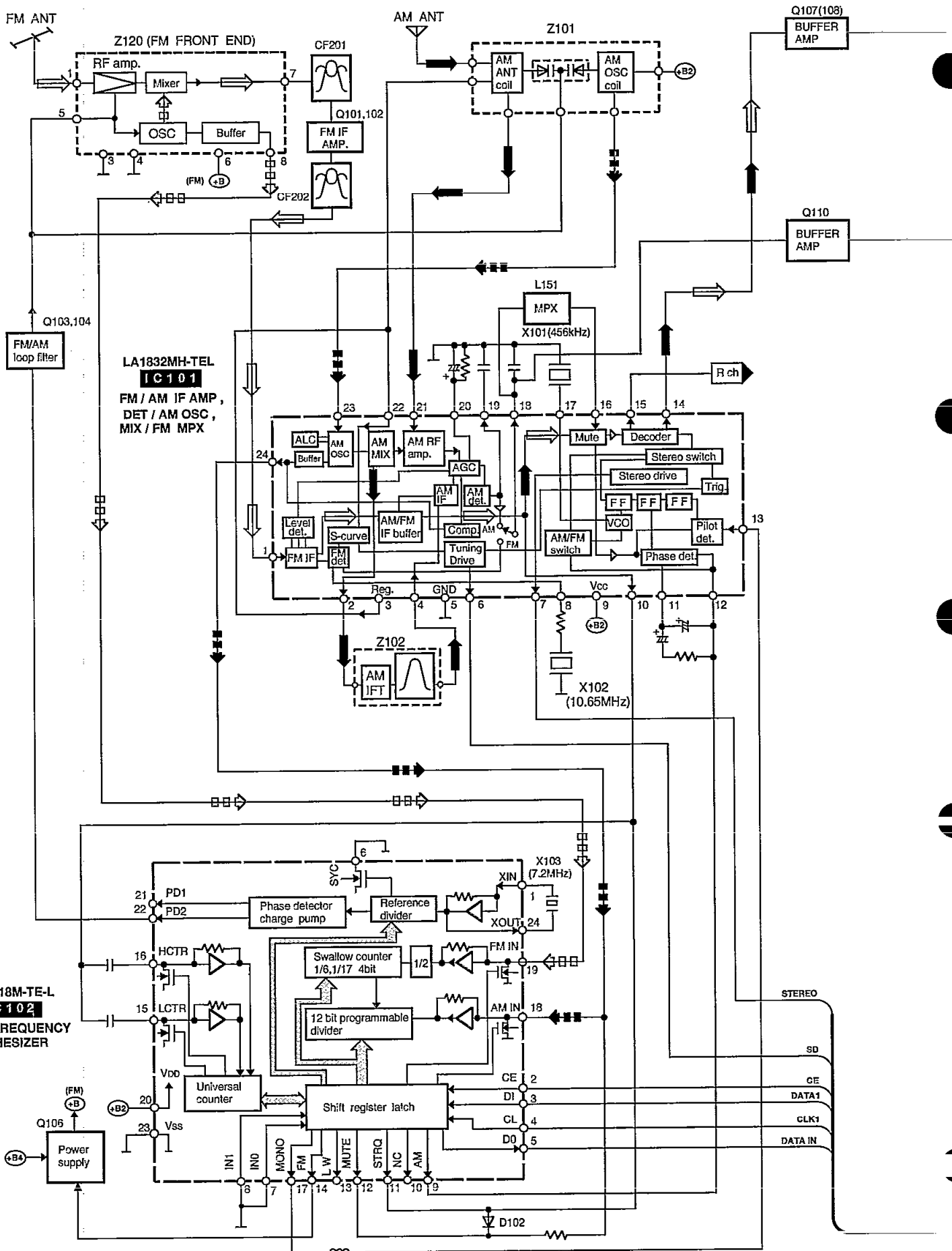

● Signal line \Rightarrow : FM signal $\square \square \triangleright$: FM OSC signal $\blacksquare \rightarrow$: AM signal $\blacksquare \blacksquare \rightarrow$: AM OSC signal
 \Rightarrow : Rec out signal ※ () indicates pin No. of right channel.

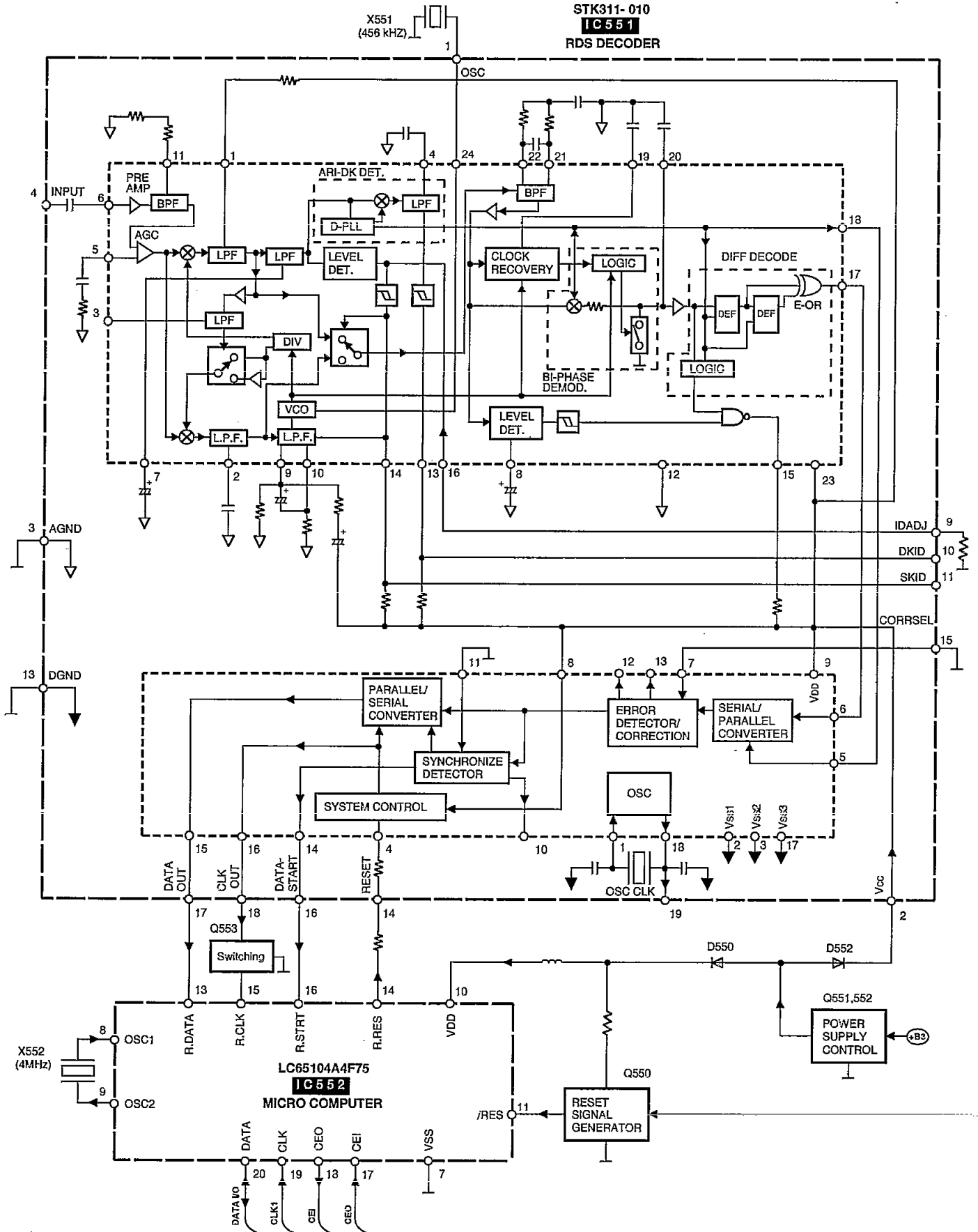

◊ Signal line \Rightarrow : FM signal \Rightarrow : AM signal \Rightarrow : Rec out signal
 ※ () indicates pin No. of right channel.

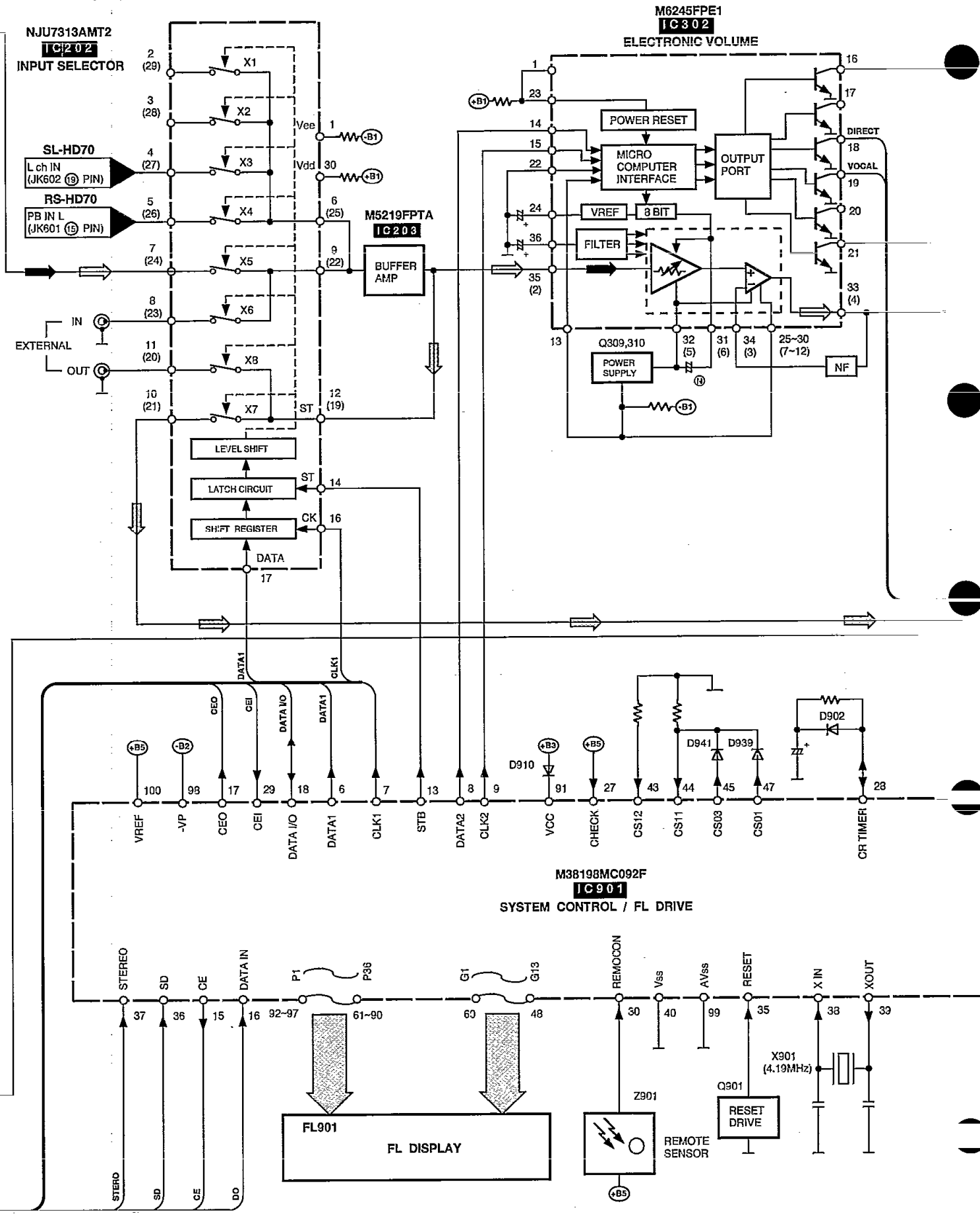

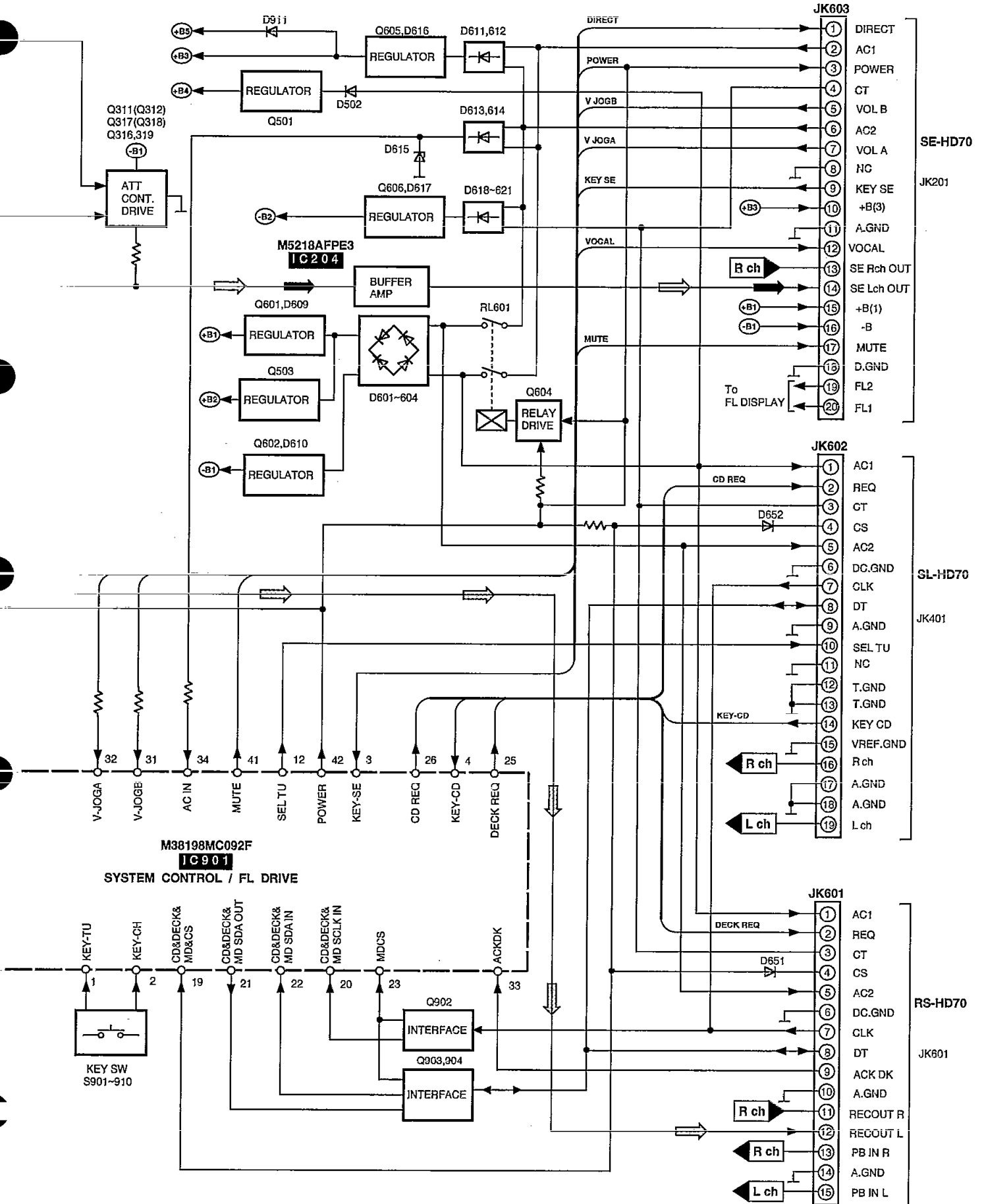

■ To Supply Power Source

This unit ST-HD70 is designed to operate on power supplied from the Amplifier SE-HD70.

When operating the unit ST-HD70 alone for testing and servicing, without having power supplied from the Amplifier SE-HD70, use the following method.

Power Supply to Main Circuit

1. Short the section between the test points **TP602** (**[CT]**) and **TP610** (**[D.GND]**), and as well as the section between the test points **A.GND** and **TP610** (**[D.GND]**).
2. Connect the 10V AC power to pin ① of the indicator module FL901 and the GND terminal to pin ④ of the same FL901 module.
3. Apply 10V AC power to the section between the point **TP601** (**[AC]**) and the point **TP602** (**[CT]**) as well as the section between the point **TP603** (**[AC]**) and the point **TP602** (**[CT]**). This unit comes to stand-by mode.
4. Short the section between the test points **TP611** and **TP610** (**[D.GND]**) for a moment. The main circuit comes to power ON mode. (Whenever this operation is performed, power, ON/OFF mode is repeated.)

To Check Signals

Connect the oscilloscope to the section between the point LINE OUT (Rch) of jumper J610 and the point **TP610** (**[D.GND]**) as well as the section between the point LINE OUT (Lch) of jumper J611 and the **TP610** (**[D.GND]**), or the speaker with the built-in amplifier to the EXTERNAL (OUT) terminals and check if the signals are outputting from this unit.

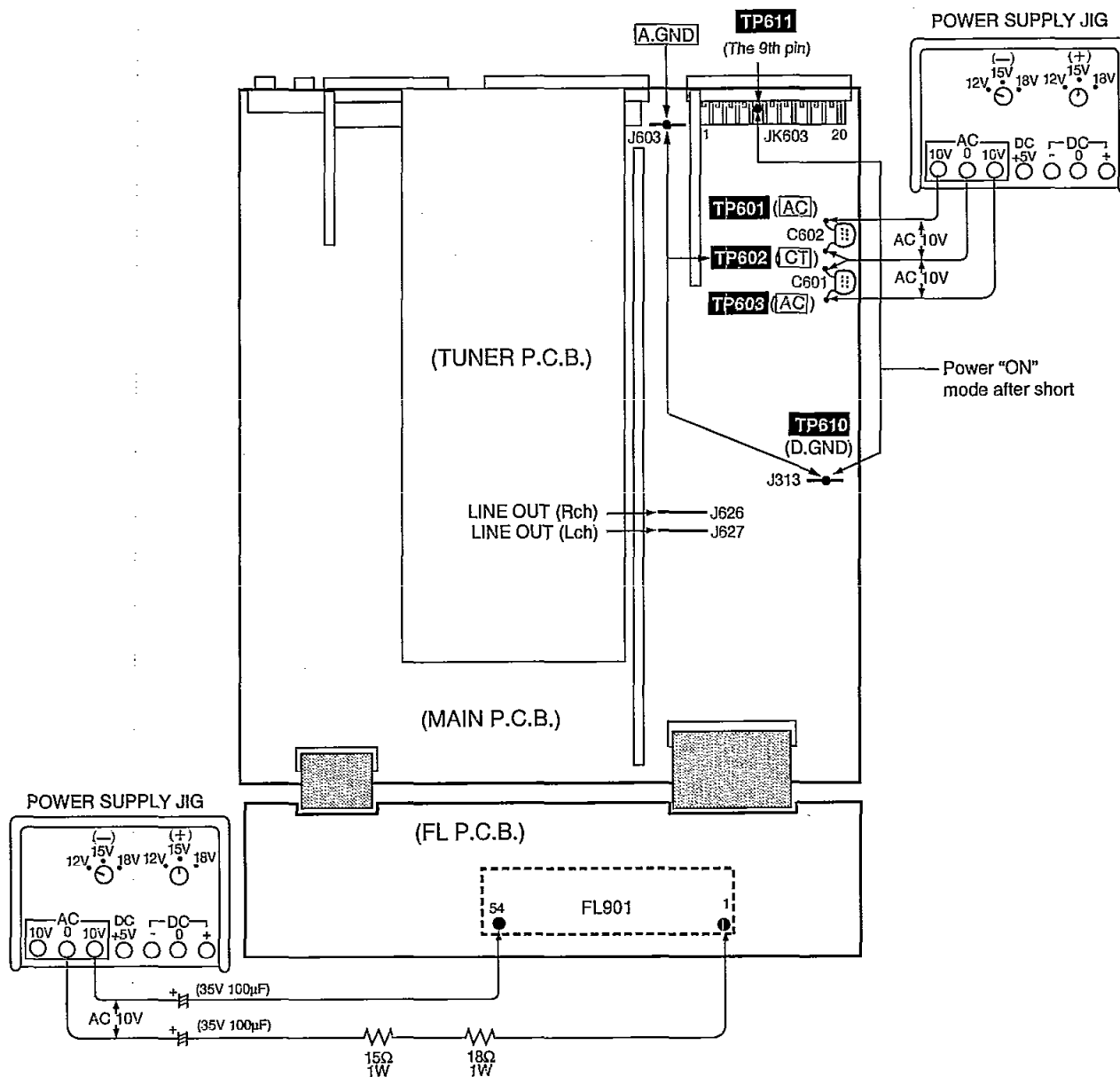

Schematic Diagram (Parts list on pages 25~28.)

- This schematic diagram may be modified at any time with development of new technology.

A	TUNER CIRCUIT	16, 17
B	RDS CIRCUIT	18
C	INPUT/OUTPUT CIRCUIT	19
D	MAIN CIRCUIT	19~21
E	FL CIRCUIT	22, 23
F	OPERATION CIRCUIT	23

Notes:

- S901: Record timer switch (⊕ REC)
- S902: Play timer switch (⊕ PLAY)
- S907: Tuning mode select switch (TUNING MODE)
- S903: Clock/timer switch (CLOCK/TIMER)
- S904: Set switch (SET)
- S905, 906: Tuning/Time adjust switch (TUNING/TIME ADJUST)
(S905: DOWN, S906: UP)
- S908: Source input select switch (INPUT SELECTOR)
- S909: RDS display mode switch (RDS DISPLAY MODE)
- S910: FM/AM switch (FM/AM)

- Indicated voltage values are the standard values for the unit measured by the DC electronic circuit tester (high-impedance) with the chassis taken as standard. Therefore, there may exist some errors in the voltage values, depending on the internal impedance of the DC circuit tester.

- Voltage values and waveforms are measured as indicated in the schematic diagram when test points between **TP602** and **TP610**, and between **TP610** and **A. GND**, and between **TP609** and **A. GND** are shorted.

No mark: FM mode () : AM mode

- Important safety notice:

Components identified by \triangle mark have special characteristics important for safety.

Furthermore, special parts which have purpose of fire-retardant (resistors), high-quality sound (capacitors), low-noise (resistors), etc. are used. When replacing any of components, be sure to use only manufacturer's specified parts shown in the parts list.

- Caution!

IC and LSI are sensitive to static electricity.

Secondary trouble can be prevented by taking care during repair.







Cover the parts boxes made of plastics with aluminum foil.

Ground the soldering iron.

Put a conductive mat on the work table.

Do not touch the legs of IC or LSI with the fingers directly.

- Voltage and signal line

	: Positive voltage line		: Negative voltage line
	: FM signal line		: FM OSC signal line
	: AM signal line		: AM OSC signal line
	: REC OUT line		

Replacement of the Foot

1. Remove the 4 heat melted posts on the Bottom board ass'y with a pair of nippers or similar tool.
2. To replace the foot (RKA0076-N) on the Bottom board ass'y melt the 4 posts with a soldering iron or install it with a screw (XTB3+6J).

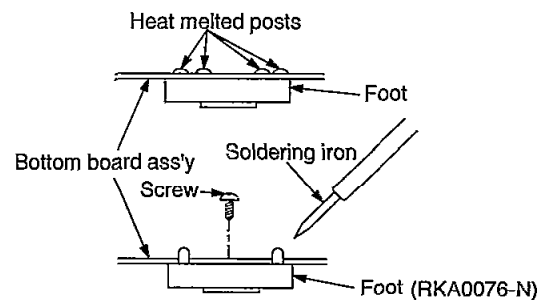

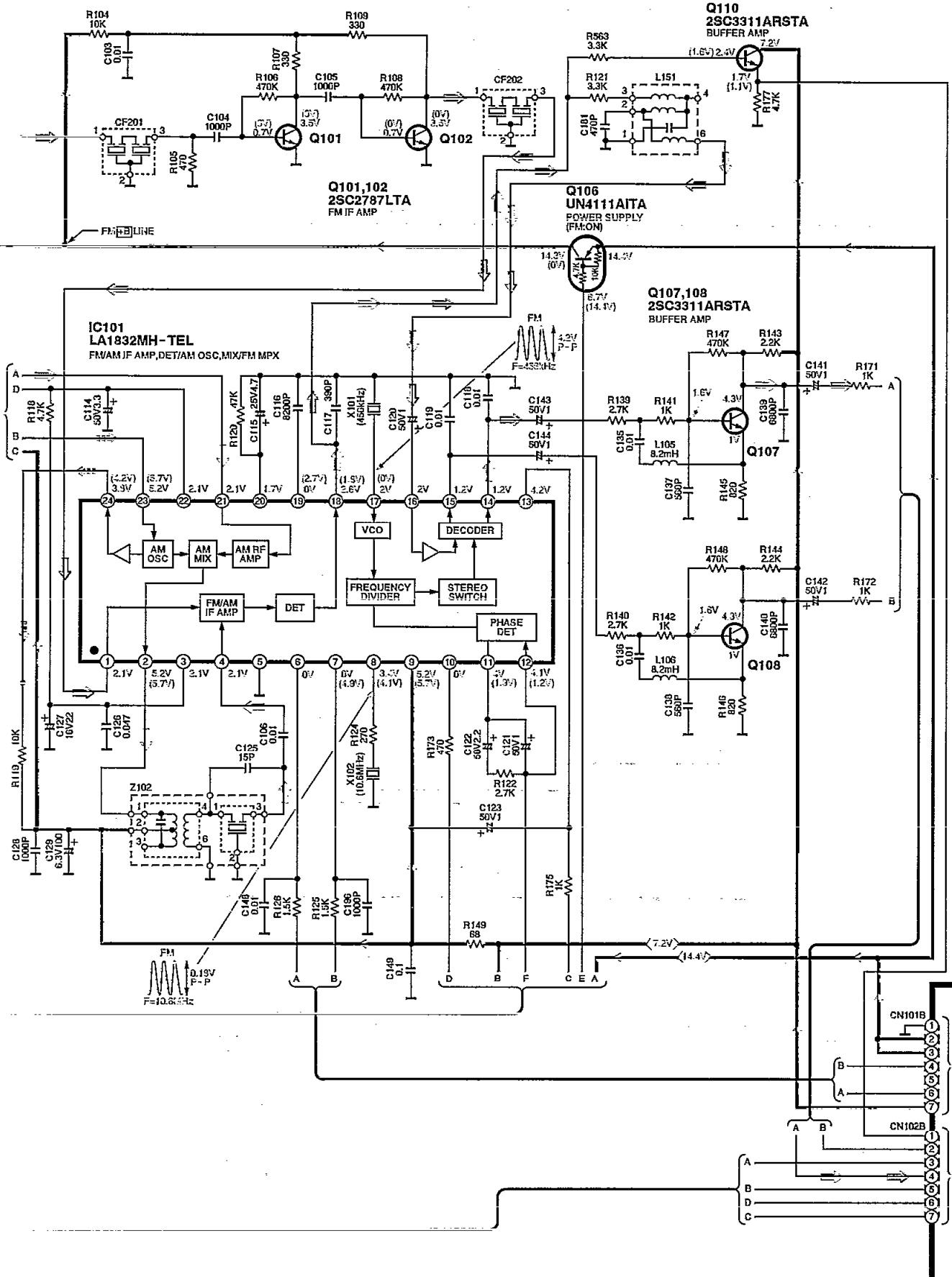

Notes: ● → : FM signal ● → : REC OUT signal
● → : AM signal

B RDS CIRCUIT (P.C.Board: on page 24)

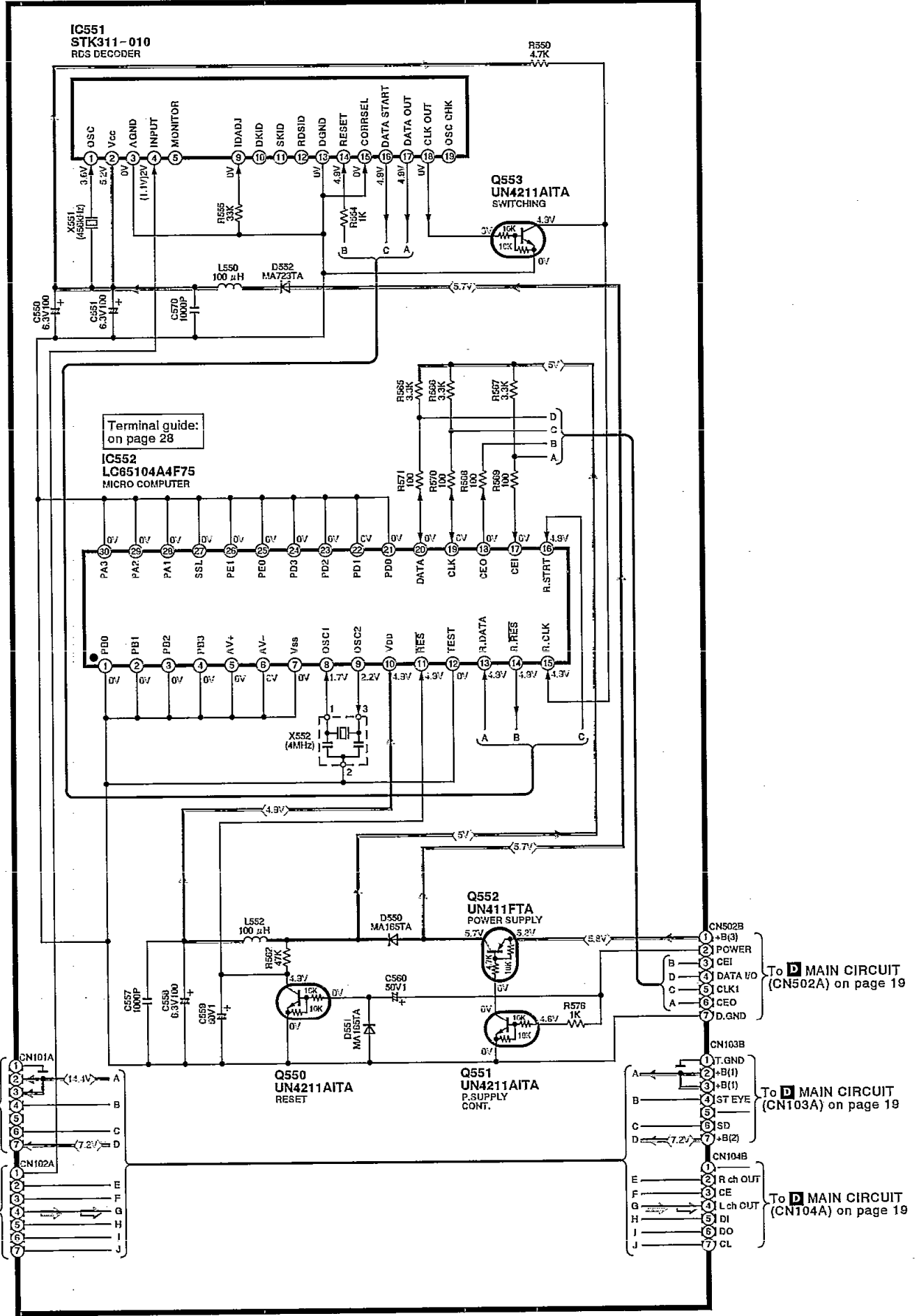

Terminal guide: on page 28

To **D** MAIN CIRCUIT (CN502A) on page 19

To **D** MAIN CIRCUIT (CN103A) on page 19

To **D** MAIN CIRCUIT (CN104A) on page 19

C INPUT/OUTPUT
CIRCUIT
(P.C.Board: on page 24)

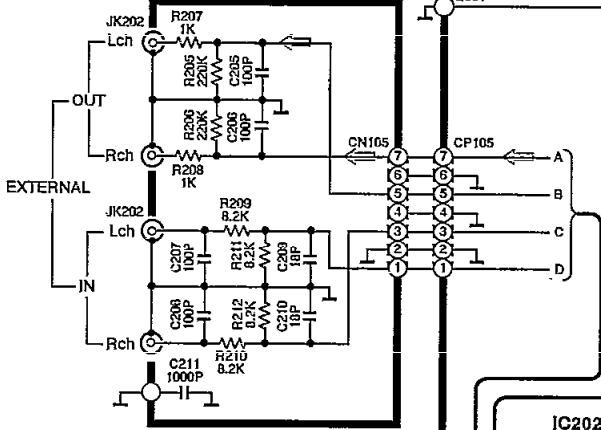

D MAIN CIRCUIT (P.C.Board: on page 25)

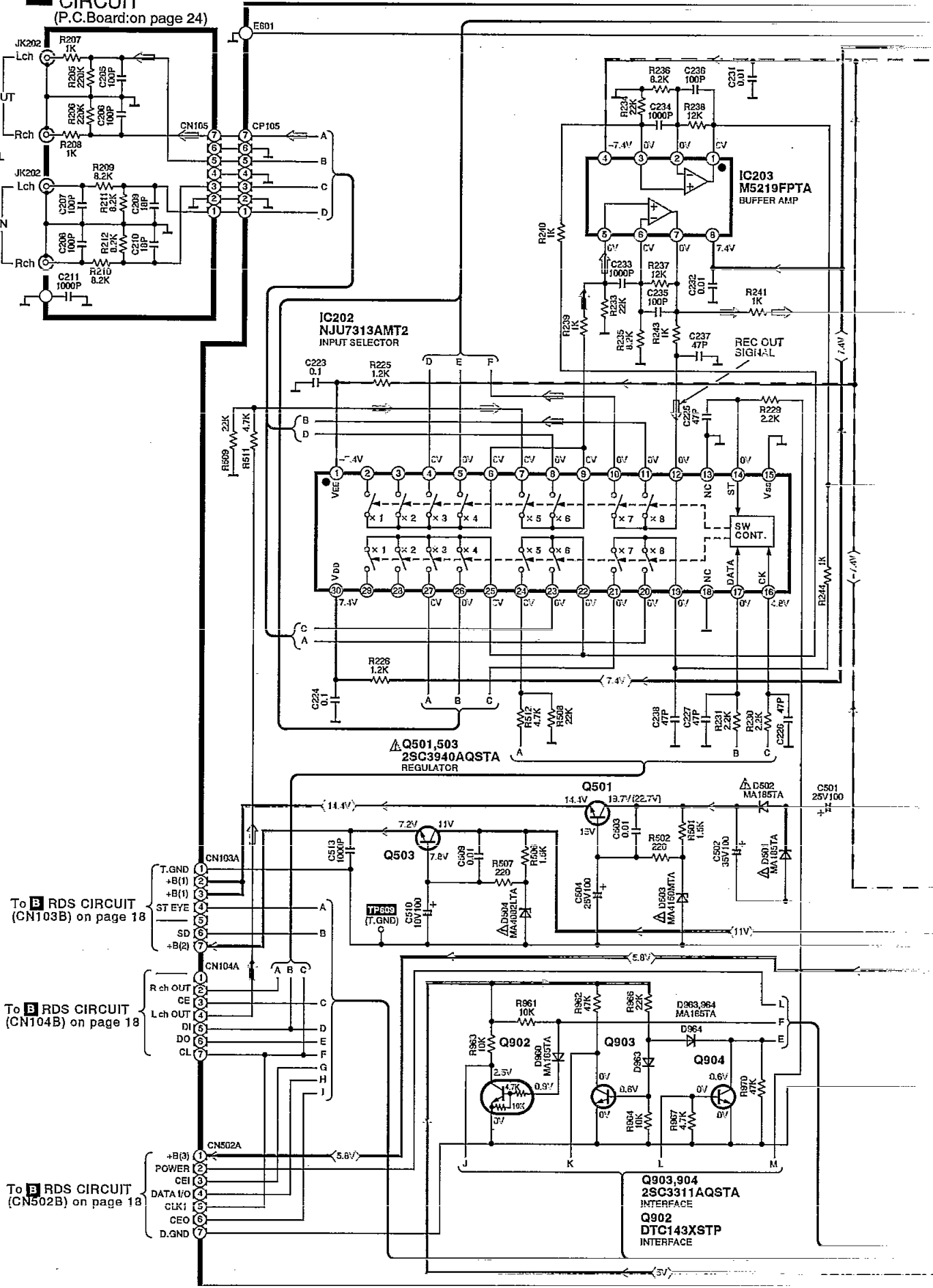

Notes: • → : FM signal • → : REC OUT signal
• → : AM signal

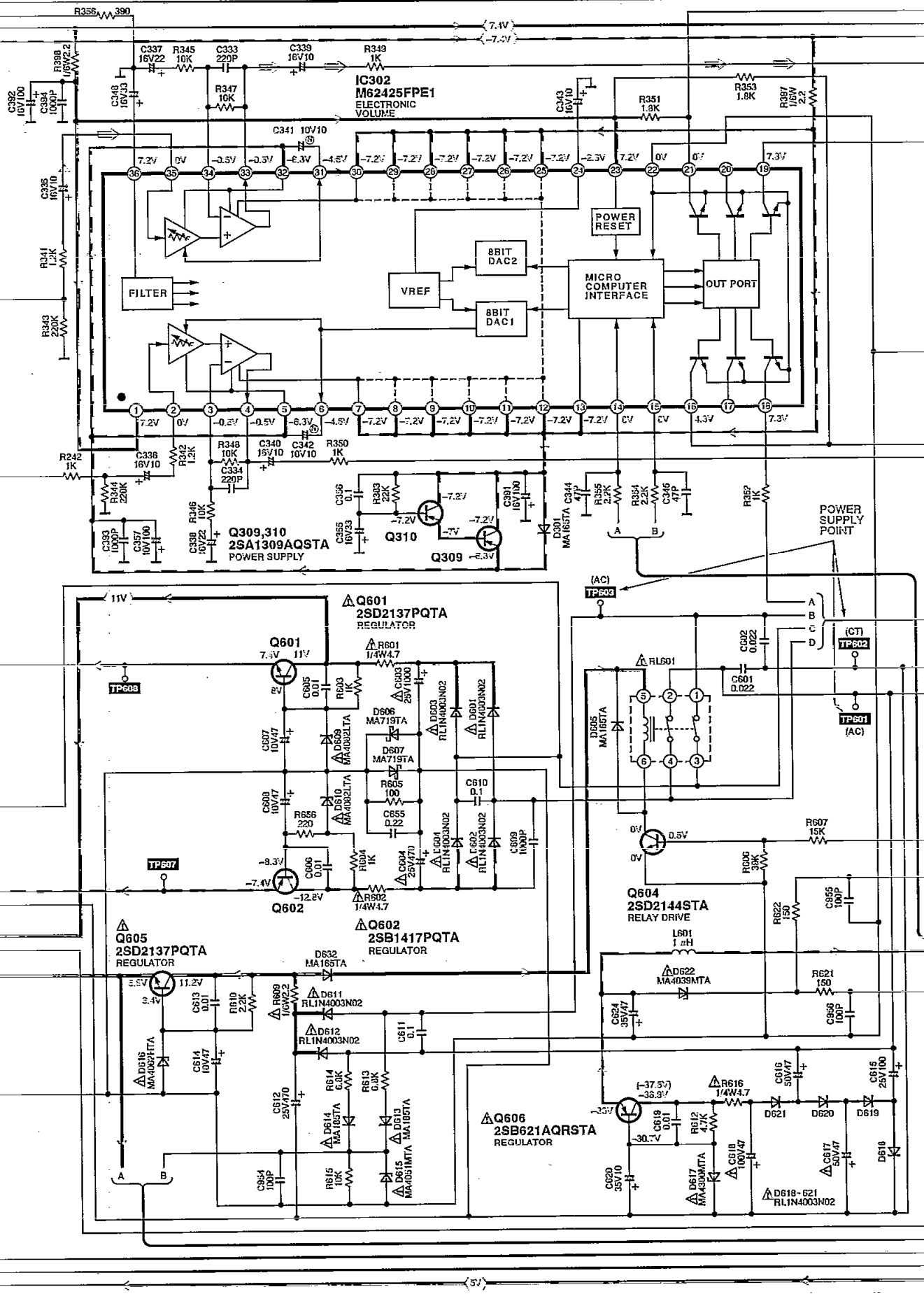

D MAIN CIRCUIT (P.C.Board: on page 25)

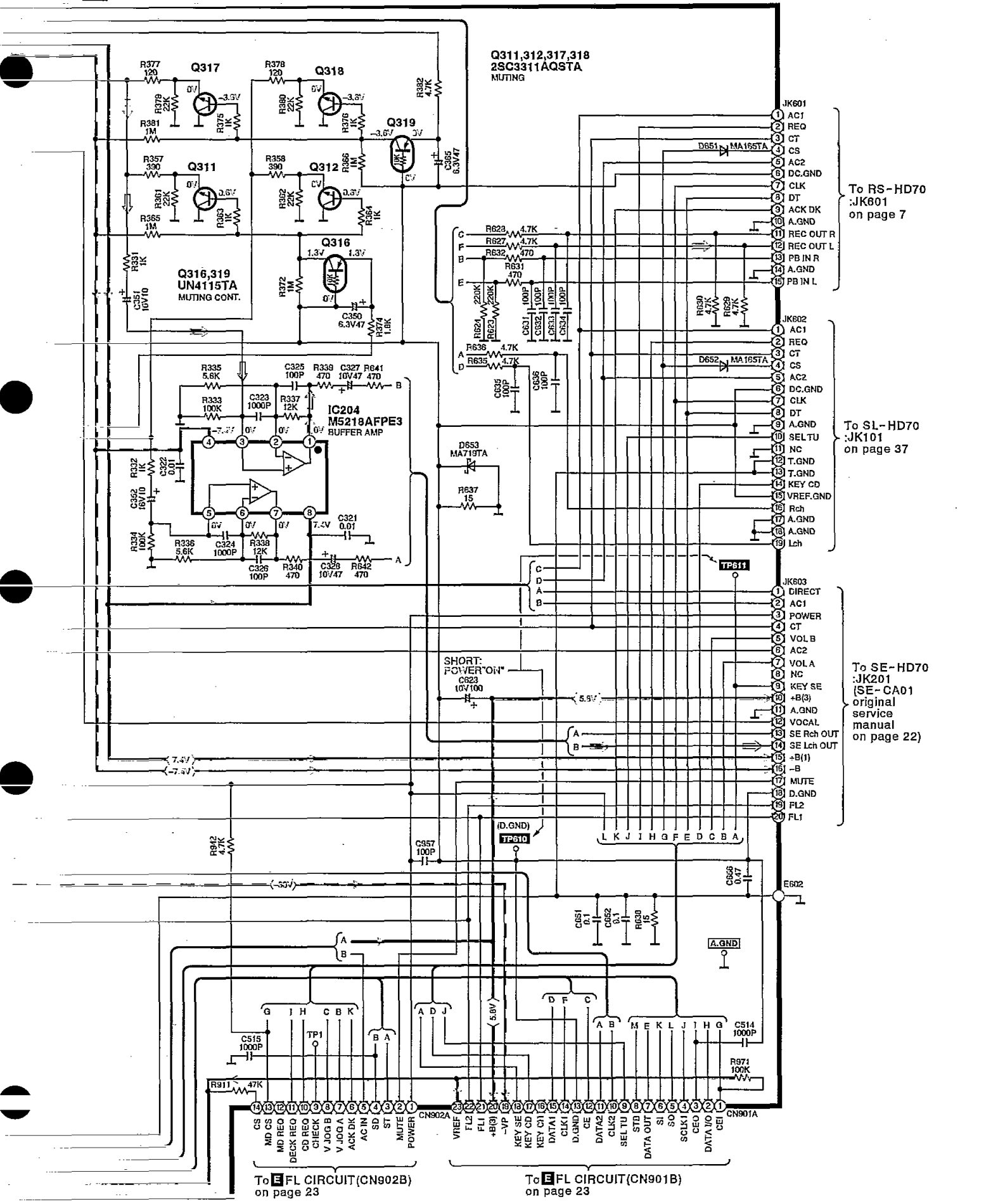

E FL CIRCUIT (P.C.Board: on page 26)

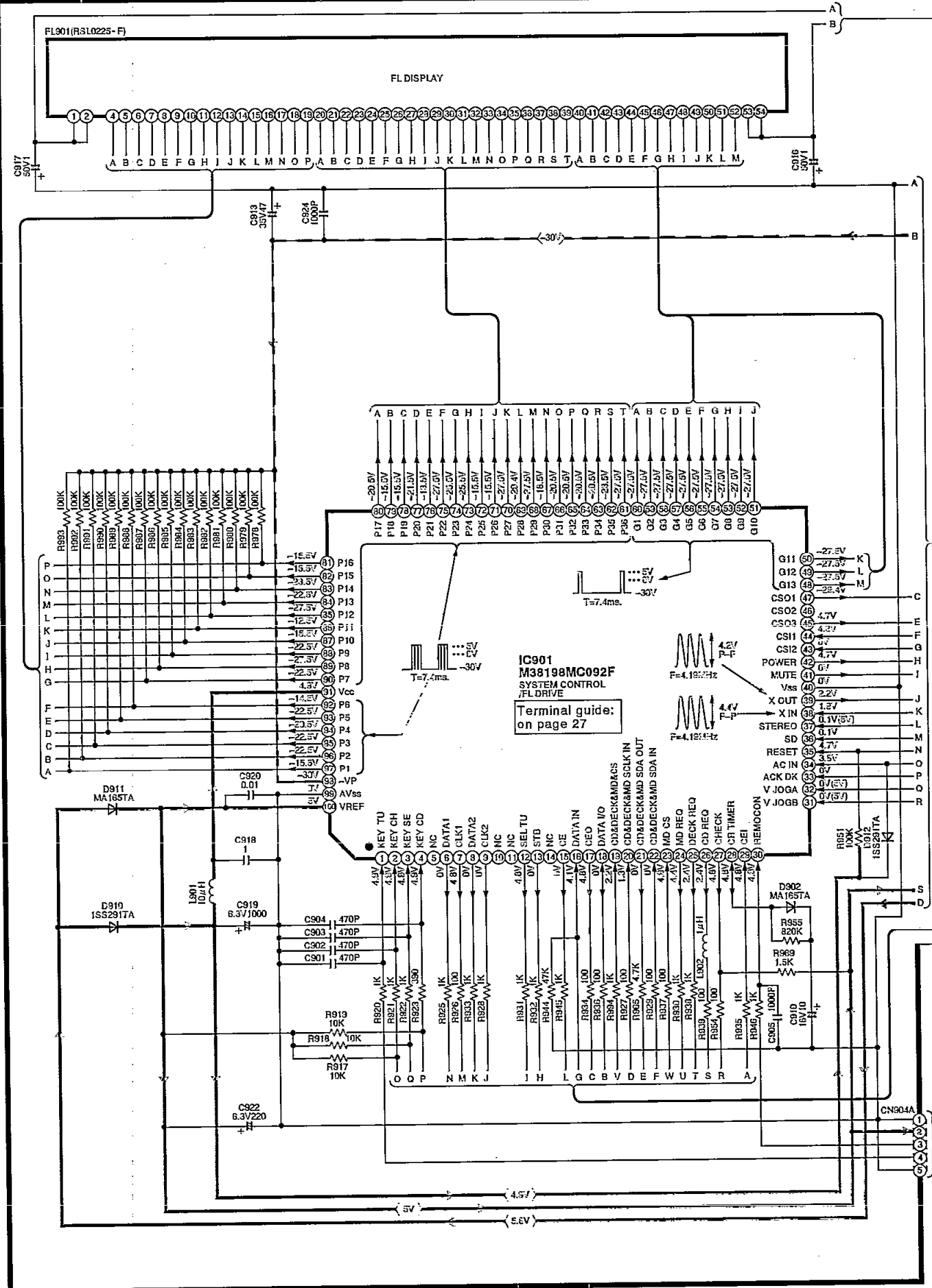

IC901
M38198MC092F
 SYSTEM CONTROL
 iFL DRIVE

Terminal guide:
 on page 27

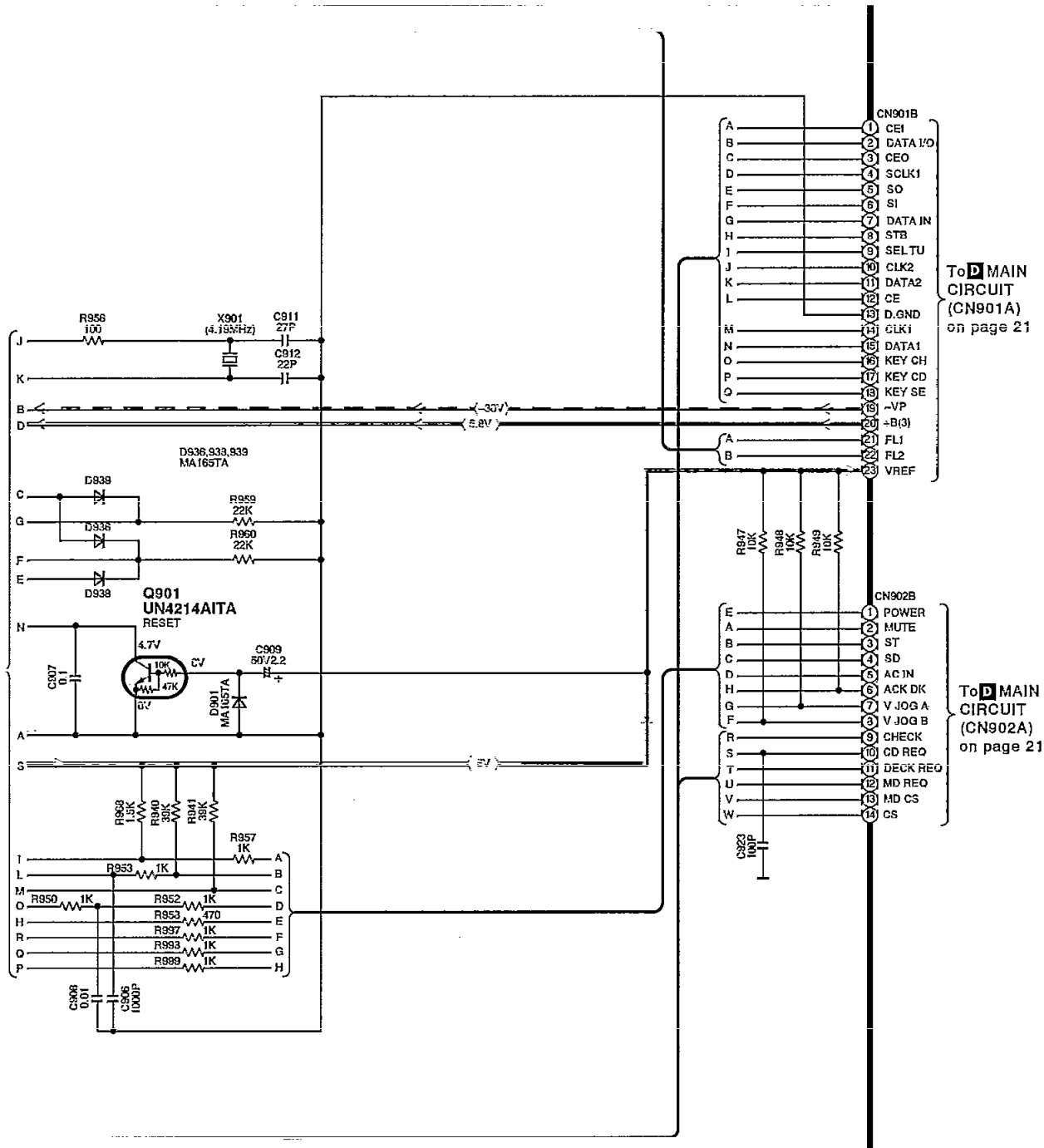

To **D** MAIN CIRCUIT (CN901A) on page 21

To **D** MAIN CIRCUIT (CN902A) on page 21

F OPERATION CIRCUIT (P.C.Board: on page 26)

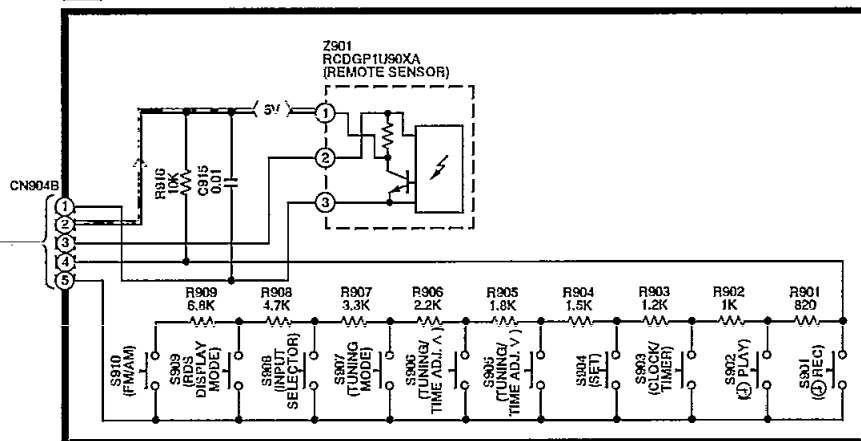

Printed Circuit Board Diagram

• This circuit board diagram may be modified at any time with the development of new technology.

B RDS P.C.B.

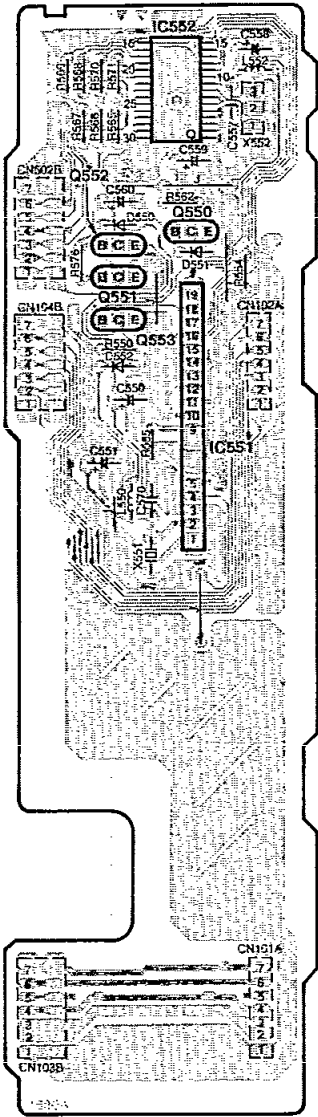

(REP2375A-T)

A TUNER P.C.B.

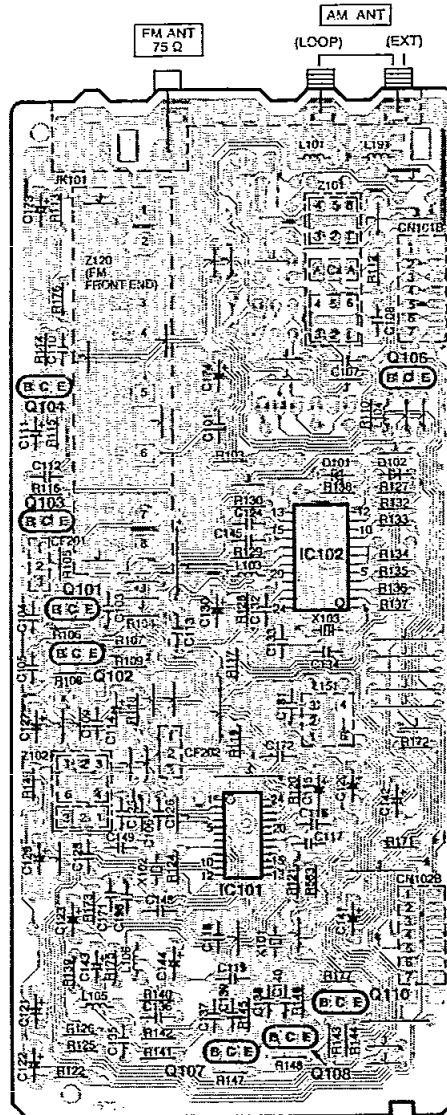

(REP2374A-T)

C INPUT/OUTPUT P.C.B.

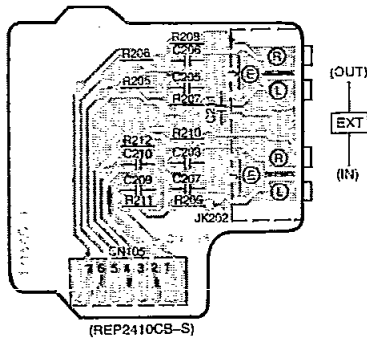

(REP2410CB-S)

SHORT:POWER *ON*

POWER SUPPLY POINT

D MAIN P.C.B.

TP608 TP607 (D.GND) TP610

(AC) (CT) (AC)
TP603 TP602 TP601

A.GND

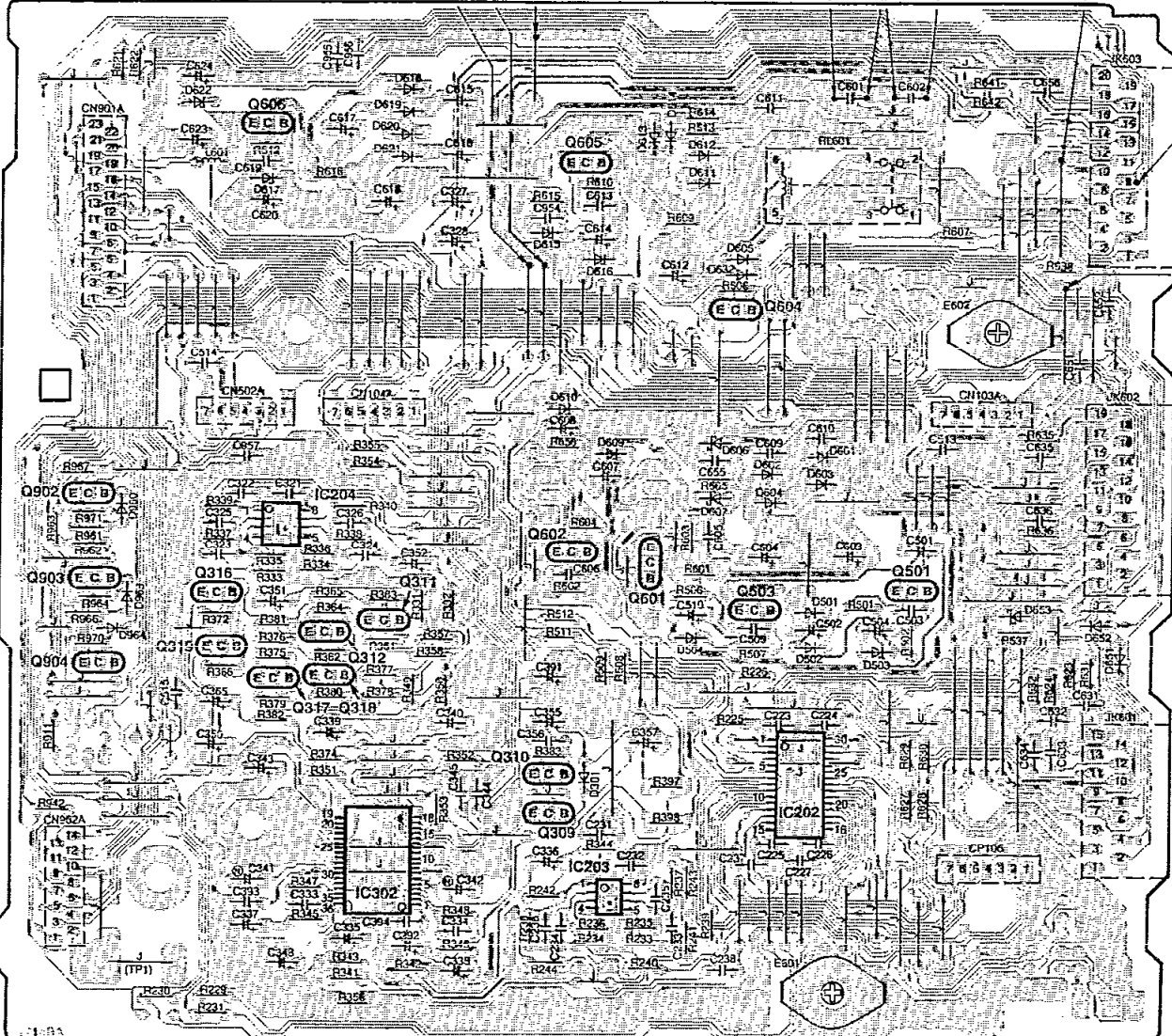

TP611

SE-HD70

(T.GND) TP609

SL-HD70

RS-HD70

(REP2498B-M)

E FL P.C.B.

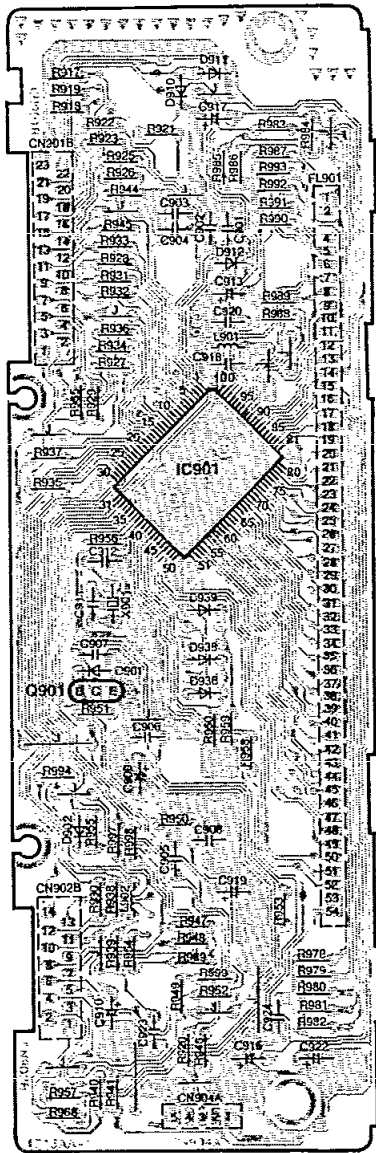

(REP2410CA-S)

F OPERATION P.C.B.

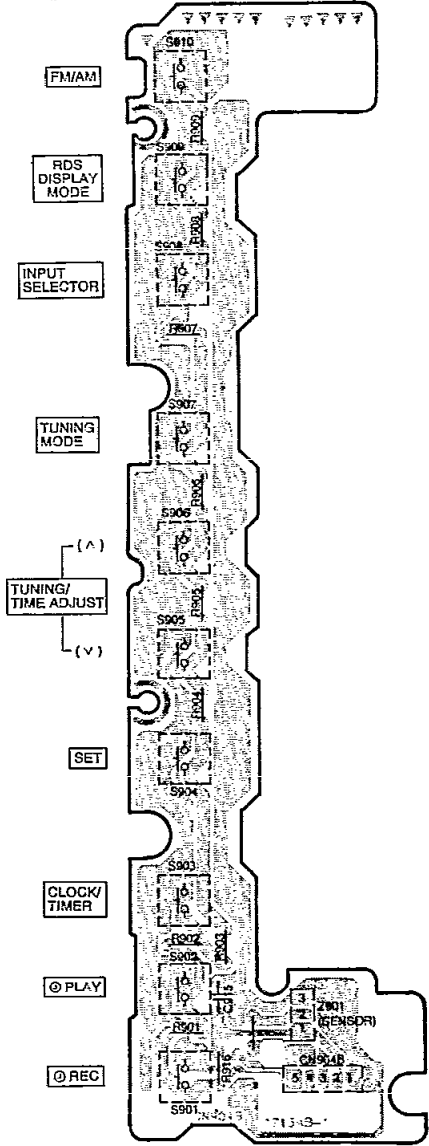

(REP2410CA-S)

Terminal Guide

● IC901 (M38198MC092F): SYSTEM CONTROL/ FL DRIVE

Pin No.	Mark	I/O	Function
1	KEY-TU	I	Tuner operation switch signal input
2	KEY-CH	I	Not used, open
3	KEY-SE	I	Operation switch signal input for SE-HD70
4	KEY-CD	I	Operation switch signal input for SL-HD70
5	NC	—	Not used
6	DATA1	O	Serial data output for IC102 and IC202
7	CLK1	O	Clock output for IC102, IC202 and IC552
8	DATA2	O	Serial data output for IC302
9	CLK2	O	Clock output for IC302
10	NC	—	Not used, open
11	NC	—	Not used, open
12	SEL_TU	O	Not used, open with SL-HD70
13	STB	O	Strobe signal output for IC202
14	NC	—	Not used, open
15	CE	O	Chip enable signal output for IC102
16	DATA IN	I	Data input from IC102
17	CEO	O	Serial data output for IC552
18	DATA I/O	I/O	Serial data input/output for IC552
19	CD & DECK & MD & CS	I	Serial data communication starting signal input
20	CD & DECK & MD SCLK IN	I	Serial clock input
21	CD & DECK & MD SDA OUT	O	Serial data output
22	CD & DECK & MD SDA IN	I	Serial data input
23	MD CS	—	Not used
24	MD REQ	—	Not used
25	DECK REQ	O	Request signal output for RS-HD70
26	CD REQ	O	Request signal output for SL-HD70
27	CHECK	O	Test terminal
28	CR TIMER	I/O	Capacitor and resistor oscillation terminal
29	CEI	I	Serial data input for IC552
30	REMOCON	I	Remove control signal input
31	V-JOGB	I	Volume control signal input
32	V-JOGA	I	



Pin No.	Mark	I/O	Function
33	ACK DK	I	Not used, connected to GND with RS-HD70
34	AC IN	I	AC power source input terminal
35	RESET	I	Reset signal input
36	SD	I	Received signal input terminal
37	STEREO	I	Stereo signal input terminal
38	X IN	I	Connected to the ceramic oscillator (F=4.19MHz)
39	X OUT	O	
40	Vss	—	GND terminal
41	MUTE	O	Muting signal output
42	POWER	O	Power control signal output
43	CS12	I	Chip select terminal
44	CS11	I	
45	CS03	O	Chip select terminal
47			
48	G13	O	Grid signal output
60	G1		
61	P36	O	Segment signal output
90	P7		
91	Vcc	I	Power supply terminal
92	P6	O	Segment signal output
97	P1		
98	-VP	I	Negative power supply terminal
99	AVSS	—	GND terminal
100	VREF	I	Reference voltage input terminal

● IC552 (LC65104A4F75): MICROCOMPUTER

Pin No.	Mark	I/O	Function
1	PB0	—	Not used
2	PB1	—	Not used
3	PB2	—	Not used
4	PB3	—	Not used
5	AV+	—	Not used
6	AV-	—	Not used
7	VSS	—	GND terminal
8	OSC1	I	Oscillating terminal (f=4MHz)
9	OSC2	O	Oscillating terminal (f=4MHz)
10	VDD	I	+5V
11	$\overline{\text{RES}}$	I	Reset signal input
12	TEST	—	Not used
13	R. DATA	I	RDS data signal input
14	R. $\overline{\text{RES}}$	O	RDS reset signal output
15	R. CLK	I	RDS clock signal input

Pin No.	Mark	I/O	Function
16	R. STRT	I	RDS start signal input
17	CEI	I	Serial data input detection terminal
18	CEO	O	Serial data output detection terminal
19	CLK	I/O	Serial clock input/output terminal
20	DATA	I/O	Serial data input/output terminal
21	PD0	—	Not used
22	PD1	—	Not used
23	PD2	—	Not used
24	PD3	—	Not used
25	PE0	—	Not used
26	PE1	—	Not used
27	SSL	—	Not used
28	PA1	—	Not used
29	PA2	—	Not used
30	PA3	—	Not used

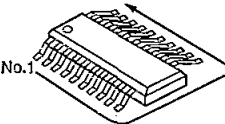
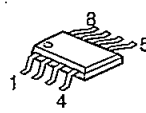
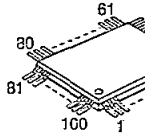
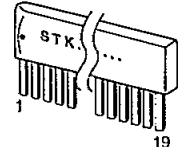
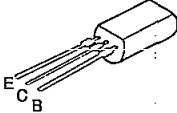
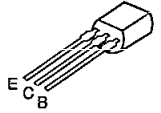
● Terminal guide of IC's transistors and diodes

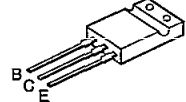
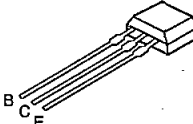
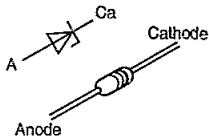
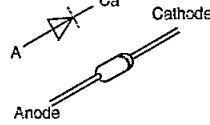
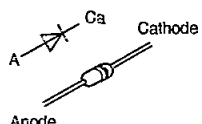
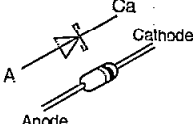
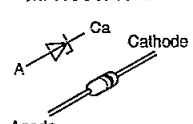
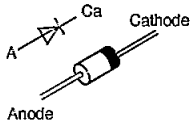
 <table border="1" data-bbox="478 1120 718 1276"> <tr> <td>LA1832MH-TEL</td> <td>24PIN</td> </tr> <tr> <td>LC7218M-TE-L</td> <td>24PIN</td> </tr> <tr> <td>NJU7313AMT2</td> <td>30PIN</td> </tr> <tr> <td>LC65104A4F75</td> <td>30PIN</td> </tr> <tr> <td>M62425FPE1</td> <td>36PIN</td> </tr> </table>		LA1832MH-TEL	24PIN	LC7218M-TE-L	24PIN	NJU7313AMT2	30PIN	LC65104A4F75	30PIN	M62425FPE1	36PIN	<table border="1" data-bbox="774 1120 981 1187"> <tr> <td>M5218AFPE3</td> <td>8PIN</td> </tr> <tr> <td>M5219FPTA</td> <td>8PIN</td> </tr> </table> 	M5218AFPE3	8PIN	M5219FPTA	8PIN	<p>M38198MC092</p> 	<p>STK311-010</p> 
LA1832MH-TEL	24PIN																	
LC7218M-TE-L	24PIN																	
NJU7313AMT2	30PIN																	
LC65104A4F75	30PIN																	
M62425FPE1	36PIN																	
M5218AFPE3	8PIN																	
M5219FPTA	8PIN																	
<p>2SC3940AQSTA</p> 	<p>2SB621AQRSTA</p> 		<p>2SA1309AQSTA 2SC2785FETA 2SC2787LTA 2SC3311AQSTA 2SC3311ARSTA</p> <p>UN411FTA UN4111AITA UN4115TA UN4211AITA UN4214AITA</p>	<p>2SB1417PQTA 2SD2137PQTA</p> 														
<p>2SD2144STA DTC143XSTP</p> 	<p>MA4039MTA MA4051MTA MA4062HTA MA4082LTA</p> 	<p>1SS291TA MA165TA MA723TA</p> 	<p>MA185TA</p> 															
<p>MA719TA</p> 	<p>MA4150MTA MA4300MTA</p> 	<p>RL1N4003N02</p> 																

Resistors and Capacitors

Notes: * Capacity values are in microfarads (uF) unless specified otherwise, P=Pico-farads (pF) F=Farads (F)
 * Resistance values are in ohms, unless specified otherwise, 1K=1,000 (OHM), 1M=1,000k (OHM)
 * [M] indicates in Remarks columns parts that are supplied by MESA.

Ref. No.	Part No.	Values & Remarks	Ref. No.	Part No.	Values & Remarks	Ref. No.	Part No.	Values & Remarks
		RESISTORS	R237, 238	ERDS2TJ123	1/4W 12K [M]	R612	ERDS2TJ472	1/4W 4.7K [M]
			R239-244	ERDS2TJ102	1/4W 1K [M]	R613, 614	ERDS2TJ682T	1/4W 6.8K [M]
			R331, 332	ERDS2TJ102	1/4W 1K [M]	R615	ERDS2TJ103	1/4W 10K [M]
R103	ERDS2TJ101	1/4W 100 [M]	R333, 334	ERDS2TJ104	1/4W 100K [M]	R616	ERD25FVJ4R7T	1/4W 4.7 [M]△
R104	ERDS2TJ103	1/4W 10K [M]	R335, 336	ERDS2TJ562	1/4W 5.6K [M]	R621, 622	ERDS2TJ151	1/4W 150 [M]
R105	ERDS2TJ471	1/4W 470 [M]	R337, 338	ERDS2TJ123	1/4W 12K [M]	R623, 624	ERDS2TJ224T	1/4W 220K [M]
R106	ERDS2TJ474	1/4W 470K [M]	R339, 340	ERDS2TJ471	1/4W 470 [M]	R627-630	ERDS2TJ472	1/4W 4.7K [M]
R107	ERDS2TJ331	1/4W 330 [M]	R341, 342	ERDS2TJ122	1/4W 1.2K [M]	R631, 632	ERDS2TJ471	1/4W 470 [M]
R108	ERDS2TJ474	1/4W 470K [M]	R343, 344	ERDS2TJ224T	1/4W 220K [M]	R635, 636	ERDS2TJ472	1/4W 4.7K [M]
R109	ERDS2TJ331	1/4W 330 [M]	R345-348	ERDS2TJ103	1/4W 10K [M]	R637, 638	ERDS2TJ150T	1/4W 15 [M]
R110	ERDS2TJ102	1/4W 1K [M]	R349, 350	ERDS2TJ102	1/4W 1K [M]	R641, 642	ERDS2TJ471	1/4W 470 [M]
R112	ERDS2TJ104	1/4W 100K [M]	R351	ERDS2TJ182	1/4W 1.8K [M]	R656	ERDS2TJ221	1/4W 220 [M]
R113	ERDS2TJ103	1/4W 10K [M]	R352	ERDS2TJ102	1/4W 1K [M]	R901	ERDS2TJ821	1/4W 820 [M]
R114	ERDS2TJ562	1/4W 5.6K [M]	R353	ERDS2TJ182	1/4W 1.8K [M]	R902	ERDS2TJ102	1/4W 1K [M]
R115	ERDS2TJ561	1/4W 560 [M]	R354, 355	ERDS2TJ222	1/4W 2.2K [M]	R903	ERDS2TJ122	1/4W 1.2K [M]
R116	ERDS2TJ102	1/4W 1K [M]	R356-358	ERDS2TJ391	1/4W 390 [M]	R904	ERDS2TJ152	1/4W 1.5K [M]
R117	ERDS2TJ823T	1/4W 82K [M]	R361, 362	ERDS2TJ223	1/4W 22K [M]	R905	ERDS2TJ182	1/4W 1.8K [M]
R118	ERDS2TJ472	1/4W 4.7K [M]	R363, 364	ERDS2TJ102	1/4W 1K [M]	R906	ERDS2TJ222	1/4W 2.2K [M]
R119	ERDS2TJ103	1/4W 10K [M]	R365, 366	ERDS2TJ105T	1/4W 1M [M]	R907	ERDS2TJ332	1/4W 3.3K [M]
R120	ERDS2TJ473	1/4W 47K [M]	R372	ERDS2TJ105T	1/4W 1M [M]	R908	ERDS2TJ472	1/4W 4.7K [M]
R121	ERDS2TJ332	1/4W 3.3K [M]	R374	ERDS2TJ182	1/4W 1.8K [M]	R909	ERDS2TJ682T	1/4W 6.8K [M]
R122	ERDS2TJ272T	1/4W 2.7K [M]	R375, 376	ERDS2TJ102	1/4W 1K [M]	R911	ERDS2TJ473	1/4W 47K [M]
R124	ERDS2TJ271	1/4W 270 [M]	R377, 378	ERDS2EJ121	1/4W 120 [M]	R916-919	ERDS2TJ103	1/4W 10K [M]
R125, 126	ERDS2TJ152	1/4W 1.5K [M]	R379, 380	ERDS2TJ223	1/4W 22K [M]	R920-922	ERDS2TJ102	1/4W 1K [M]
R127	ERDS2TJ103	1/4W 10K [M]	R381	ERDS2TJ105T	1/4W 1M [M]	R923	ERDS2TJ391	1/4W 390 [M]
R128	ERDS2TJ820	1/4W 82 [M]	R382	ERDS2TJ472	1/4W 4.7K [M]	R925	ERDS2TJ102	1/4W 1K [M]
R129	ERDS2TJ473	1/4W 47K [M]	R383	ERDS2TJ223	1/4W 22K [M]	R926, 927	ERDS2TJ101	1/4W 100 [M]
R130	ERDS2TJ103	1/4W 10K [M]	R397, 398	ERQ16NKW2R2E	1W 2.2 [M]	R928	ERDS2TJ102	1/4W 1K [M]
R132	ERDS2TJ103	1/4W 10K [M]	R501	ERDS2TJ152	1/4W 1.5K [M]	R929	ERDS2TJ101	1/4W 100 [M]
R133-137	ERDS2TJ102	1/4W 1K [M]	R502	ERDS2TJ221	1/4W 220 [M]	R930-933	ERDS2TJ102	1/4W 1K [M]
R138	ERDS2TJ103	1/4W 10K [M]	R506	ERDS2TJ152	1/4W 1.5K [M]	R934	ERDS2TJ101	1/4W 100 [M]
R139, 140	ERDS2TJ272T	1/4W 2.7K [M]	R507	ERDS2TJ221	1/4W 220 [M]	R935	ERDS2TJ102	1/4W 1K [M]
R141, 142	ERDS2TJ102	1/4W 1K [M]	R508, 509	ERDS2TJ223	1/4W 22K [M]	R936, 937	ERDS2TJ101	1/4W 100 [M]
R143, 144	ERDS2TJ222	1/4W 2.2K [M]	R511, 512	ERDS2TJ472	1/4W 4.7K [M]	R938	ERDS2TJ102	1/4W 1K [M]
R145, 146	ERDS2TJ821	1/4W 820 [M]	R550	ERDS2TJ472	1/4W 4.7K [M]	R939	ERDS2TJ101	1/4W 100 [M]
R147, 148	ERDS2TJ474	1/4W 470K [M]	R554	ERDS2TJ102	1/4W 1K [M]	R940, 941	ERDS2TJ393	1/4W 39K [M]
R149	ERDS2TJ680T	1/4W 68 [M]	R555	ERDS2TJ333	1/4W 33K [M]	R942	ERDS2TJ472	1/4W 4.7K [M]
R171, 172	ERDS2TJ102	1/4W 1K [M]	R562	ERDS2TJ473	1/4W 47K [M]	R944	ERDS2TJ473	1/4W 47K [M]
R173	ERDS2TJ471	1/4W 470 [M]	R563	ERDS2TJ332	1/4W 3.3K [M]	R945, 946	ERDS2TJ102	1/4W 1K [M]
R175	ERDS2TJ102	1/4W 1K [M]	R565-567	ERDS2TJ332	1/4W 3.3K [M]	R947-949	ERDS2TJ103	1/4W 10K [M]
R176	ERDS2TJ391	1/4W 390 [M]	R568-571	ERDS2TJ101	1/4W 100 [M]	R950	ERDS2TJ102	1/4W 1K [M]
R177	ERDS2TJ472	1/4W 4.7K [M]	R576	ERDS2TJ102	1/4W 1K [M]	R951	ERDS2TJ104	1/4W 100K [M]
R205, 206	ERDS2TJ224T	1/4W 220K [M]	R601, 602	ERD2FCVJ4R7T	1/4W 4.7 [M]△	R952, 953	ERDS2TJ102	1/4W 1K [M]
R207, 208	ERDS2TJ102	1/4W 1K [M]	R603, 604	ERDS2TJ102	1/4W 1K [M]	R954	ERDS2TJ101	1/4W 100 [M]
R209-212	ERDS2TJ822	1/4W 8.2K [M]	R605	ERDS2TJ101	1/4W 100 [M]	R955	ERDS2TJ824	1/4W 820K [M]
R225, 226	ERDS2TJ122	1/4W 1.2K [M]	R606	ERDS2TJ393	1/4W 39K [M]	R956	ERDS2TJ101	1/4W 100 [M]
R229-231	ERDS2TJ222	1/4W 2.2K [M]	R607	ERDS2TJ153	1/4W 15K [M]	R957	ERDS2TJ102	1/4W 1K [M]
R233, 234	ERDS2TJ223	1/4W 22K [M]	R609	ERQ16NKW2R2E	1/6W 2.2 [M]△	R958	ERDS2TJ471	1/4W 470 [M]
R235, 236	ERDS2TJ822	1/4W 8.2K [M]	R610	ERDS2TJ222	1/4W 2.2K [M]	R959, 960	ERDS2TJ223	1/4W 22K [M]

Ref. No.	Part No.	Values & Remarks	Ref. No.	Part No.	Values & Remarks	Ref. No.	Part No.	Values & Remarks
R961	ERDS2TJ103	1/4W 10K [M]	C196	ECBT1H102KB5	50V 1000P [M]	C615	ECEA1EKA101B	25V 100U [M]
R962	ERDS2TJ473	1/4W 47K [M]	C205-208	ECBT1H101KB5	50V 100P [M]	C616	ECA1HM470B	50V 47U [M]
R963, 964	ERDS2TJ103	1/4W 10K [M]	C209, 210	ECBT1H180J5	50V 18P [M]	C617	ECA1HM470B	50V 47U [M]△
R965	ERDS2TJ472	1/4W 4.7K [M]	C211	ECBT1H102KB5	50V 1000P [M]	C618	ECA2AM470B	100V 47U [M]
R966	ERDS2TJ223	1/4W 22K [M]	C223, 224	ECBT1H104ZF5	50V 0.1U [M]	C619	ECKRH103ZF5	50V 0.01U [M]
R967	ERDS2TJ472	1/4W 4.7K [M]	C225-227	ECBT1H470J5	50V 47P [M]	C620	RCE1VKA100BG	35V 10U [M]
R968, 969	ERDS2TJ152	1/4W 1.5K [M]	C231, 232	ECBT1E103ZF	25V 0.01U [M]	C623	RCE1AKA101BG	10V 100U [M]
R970	ERDS2TJ473	1/4W 47K [M]	C233, 234	ECBT1H102KB5	50V 1000P [M]	C624	ECEA1VKA470B	35V 47U [M]
R971	ERDS2TJ104	1/4W 100K [M]	C235, 236	ECBT1H101KB5	50V 100P [M]	C631-636	ECBT1H101KB5	50V 100P [M]
R978-993	ERDS2TJ104	1/4W 100K [M]	C237, 238	ECBT1H470J5	50V 47P [M]	C651, 652	ECBT1H104ZF5	50V 0.1U [M]
R994	ERDS2TJ102	1/4W 1K [M]	C321, 322	ECBT1E103ZF	25V 0.01U [M]	C655	ECQV1H224JM3	50V 0.22U [M]
R997-999	ERDS2TJ102	1/4W 1K [M]	C323, 324	ECBT1H102KB5	50V 1000P [M]	C656	ECQV1H474JM3	50V 0.47U [M]
		[M]	C325, 326	ECBT1H101KB5	50V 100P [M]	C901-904	ECBT1H471KB5	50V 470P [M]
		CAPACITORS	C327, 328	RCE1AKA470BG	10V 47U [M]	C905, 906	ECBT1H102KB5	50V 1000P [M]
			C333, 334	ECBT1H221KB5	50V 220P [M]	C907	ECBT1H104ZF5	50V 0.1U [M]
C101	ECBT1C103NS5	16V 0.01U [M]	C335, 336	RCE1CKA100BG	16V 10U [M]	C908	ECBT1E103ZF	25V 0.01U [M]
C103	ECBT1C103NS5	16V 0.01U [M]	C337, 338	ECEA1CKA220B	16V 22U [M]	C909	ECEA1HKA2R2B	50V 2.2U [M]
C104, 105	ECBT1H102KB5	50V 1000P [M]	C339, 340	RCE1CKA100BG	16V 10U [M]	C910	RCE1CKA100BG	16V 10U [M]
C106	ECBT1C103NS5	16V 0.01U [M]	C341, 342	ECEA1AKR100B	10V 10U [M]	C911	ECBT1H270JU5	50V 27P [M]
C107	ECBT1H473ZF5	50V 0.047U [M]	C343	RCE1CKA100BG	16V 10U [M]	C912	ECBT1H220GC5	50V 22P [M]
C108	ECBT1H8R2KC5	50V 8.2P [M]	C344, 345	ECBT1H470J5	50V 47P [M]	C913	ECEA1VKA470B	35V 47U [M]
C109, 110	ECBT1C103NS5	16V 0.01U [M]	C348	ECEA1CKA330B	16V 33U [M]	C915	ECBT1E103ZF	25V 0.01U [M]
C111	ECEA1EKA4R7B	25V 4.7U [M]	C350	ECEA0JKA470B	6.3V 47U [M]	C916, 917	ECEA1HKA010B	50V 1U [M]
C112	ECBT1C103NS5	16V 0.01U [M]	C351, 352	RCE1CKA100BG	16V 10U [M]	C918	ECBT1C105ZF5	16V 1U [M]
C113	ECBT1H102KB5	50V 1000P [M]	C355	ECEA1CKA330B	16V 33U [M]	C919	RCE0JU102BV	6.3V 1000U [M]
C114	RCE1HKA3R3BG	50V 3.3U [M]	C356	ECBT1H104ZF5	50V 0.1U [M]	C920	ECBT1E103ZF	25V 0.01U [M]
C115	ECEA1EKA4R7B	25V 4.7U [M]	C357	RCE1AKA101BG	10V 100U [M]	C922	ECEA0JKA221B	6.3V 220U [M]
C116	ECBT1C822KS5	16V 8200P [M]	C365	ECEA0JKA470B	6.3V 47U [M]	C923	ECBT1H101KB5	50V 100P [M]
C117	ECQP1391JZ	100V 390P [M]	C391, 392	ECEA1CKA101B	16V 100U [M]	C924	ECBT1H102KB5	50V 1000P [M]
C118, 119	ECFR1C103KR	16V 0.01U [M]	C393, 394	ECBT1H102KB5	50V 1000P [M]	C954-957	ECBT1H101KB5	50V 100P [M]
C120, 121	ECEA1HKA010B	50V 1U [M]	G501	ECEA1EKA101B	25V 100U [M]			
C122	ECEA1HKA2R2B	50V 2.2U [M]	G502	ECA1VM101B	35V 100U [M]			
C123	ECEA1HKA010B	50V 1U [M]	G503	ECBT1E103ZF	25V 0.01U [M]			
C124	ECBT1H102KB5	50V 1000P [M]	G504	ECEA1EKA101B	25V 100U [M]			
C125	ECBT1H150JC5	50V 15P [M]	G509	ECBT1E103ZF	25V 0.01U [M]			
C126	ECBT1H473ZF5	50V 0.047U [M]	G510	RCE1AKA101BG	10V 100U [M]			
C127	ECEA1CKA220B	16V 22U [M]	C513-515	ECBT1H102KB5	50V 1000P [M]			
C128	ECBT1H102KB5	50V 1000P [M]	C550, 551	ECA0JKF101B	6.3V 100U [M]			
C129, 130	ECEA0JKA101B	6.3V 100U [M]	C557	ECBT1H102KB5	50V 1000P [M]			
C132	ECBT1H102KB5	50V 1000P [M]	C558	ECEA0JKA101B	6.3V 100U [M]			
C133, 134	ECBT1H270JU5	50V 27P [M]	C559, 560	ECEA1HKA010B	50V 1U [M]			
C135, 136	ECBT1C103KS5	16V 0.01U [M]	C570	ECBT1H102KB5	50V 1000P [M]			
C137, 138	ECBT1H561KB5	50V 560P [M]	C601, 602	ECKT1H223ZF	50V 0.022U [M]			
C139, 140	ECBT1C682KR5	16V 6800P [M]	C603	ECA1EM102B	25V 1000U [M]△			
C141-144	ECEA1HKA010B	50V 1U [M]	C604	RCE1EM471BV	25V 470U [M]△			
C145	ECBT1H220JC5	50V 22P [M]	C605, 606	ECBT1E103ZF	25V 0.01U [M]			
C148	ECBT1C103NS5	16V 0.01U [M]	C607, 608	RCE1AKA470BG	10V 47U [M]			
C149	ECBT1H104ZF5	50V 0.1U [M]	C609	ECBT1H102KB5	50V 1000P [M]			
C171, 172	ECBT1H102KB5	50V 1000P [M]	C610, 611	ECBT1H104ZF5	50V 0.1U [M]			
C173	ECEA1CKA220B	16V 22U [M]	C612	RCE1EM471BV	25V 470U [M]			
C174	RCE1CKA100BG	16V 10U [M]	C613	ECBT1E103ZF	25V 0.01U [M]			
C181	ECBT1H471KB5	50V 470P [M]	C614	RCE1AKA470BG	10V 47U [M]			

Replacement Parts List

Notes: * Important safety notice:
 Components identified by Δ mark have special characteristics important for safety.
 Furthermore, special parts which have purposes of fire-retardant (resistors), high-quality sound (capacitors), low-noise (resistors), etc. are used.
 When replacing any of components, be sure to use only manufacturer's specified parts shown in the parts list.
 * [M] indicates in Remarks columns parts that are supplied by MESA.

Ref. No.	Part No.	Part Name & Description	Remarks	Ref. No.	Part No.	Part Name & Description	Remarks
		INTEGRATED CIRCUIT(S)		D550, 551	MA165	DIODE	[M]
				D552	MA723TA	DIODE	[M]
				D601-604	RL1N4003N02	DIODE	[M] Δ
IC101	LA1832MH-TEL	IC	[M]	D605	MA165	DIODE	[M]
IC102	LC7218M-TE-L	IC	[M]	D606, 607	MA719TA	DIODE	[M]
IC202	NJU7313AMT2	IC	[M]	D609, 610	MA4082LTA	DIODE	[M] Δ
IC203	M5219FPTA	IC	[M]	D611, 612	RL1N4003N02	DIODE	[M] Δ
IC204	M5218AFPE3	IC	[M]	D613, 614	MA185TA	DIODE	[M] Δ
IC302	M62425FPE1	IC	[M]	D615	MA4051MTA	DIODE	[M] Δ
IC551	STK311-010	IC	[M]	D616	MA4062-H	DIODE	[M] Δ
IC552	LC65104AMF75	IC	[M]	D617	MA4300M	DIODE	[M] Δ
IC901	M38198MCO92F	IC	[M]	D618-621	RL1N4003N02	DIODE	[M] Δ
		TRANSISTOR(S)		D622	MA4039MTA	DIODE	[M] Δ
				D632	MA165	DIODE	[M]
Q101, 102	2SC2787L	TRANSISTOR	[M]	D651, 652	MA165	DIODE	[M]
Q103, 104	2SC2785FE	TRANSISTOR	[M]	D653	MA719TA	DIODE	[M]
Q106	UN4111	TRANSISTOR	[M]	D901, 902	MA165	DIODE	[M]
Q107, 108	2SC3311AR	TRANSISTOR	[M]	D910	1SS291TA	DIODE	[M]
Q110	2SC3311AR	TRANSISTOR	[M]	D911	MA165	DIODE	[M]
Q309, 310	2SA1309A-R	TRANSISTOR	[M]	D912	1SS291TA	DIODE	[M]
Q311, 312	2SC3311A-Q	TRANSISTOR	[M]	D936	MA165	DIODE	[M]
Q316	UN4115	TRANSISTOR	[M]	D938, 939	MA165	DIODE	[M]
Q317, 318	2SC3311A-Q	TRANSISTOR	[M]	D960	MA165	DIODE	[M]
Q319	UN4115	TRANSISTOR	[M]	D963, 964	MA165	DIODE	[M]
Q501	2SC3940AQSTA	TRANSISTOR	[M] Δ			COMPONENT COMBINATION(S)	
Q503	2SC3940AQSTA	TRANSISTOR	[M] Δ	Z101	RLA2Z002M-T	COMPONENT COMBINATION	[M]
Q550, 551	UN4211	TRANSISTOR	[M]	Z102	RL12Z006M-T	COMPONENT COMBINATION	[M]
Q552	UN411FTA	TRANSISTOR	[M]	Z901	RCDGP1U90XA	REMOTE SENSOR	[M]
Q553	UN4211	TRANSISTOR	[M]			COIL(S)	
Q601	2SD2137PQTA	TRANSISTOR	[M] Δ	L101	ELESNR68MA	COIL	[M]
Q602	2SB1417PQTA	TRANSISTOR	[M] Δ	L103	ELETR47MA9	COIL	[M]
Q604	2SD2144S	TRANSISTOR	[M]	L104	ELEXT1R0KA9	COIL	[M]
Q605	2SD2137PQTA	TRANSISTOR	[M] Δ	L105, 106	ELELN822KL	COIL	[M]
Q606	2SB621A-R	TRANSISTOR	[M] Δ	L151	SLM1B10M-1M	COIL	[M]
Q901	UN4214TA	TRANSISTOR	[M]	L191	ELESNR68MA	COIL	[M]
Q902	DTC143XSTP	TRANSISTOR	[M]	L550	ELEXT101KA9	COIL	[M]
Q903, 904	2SC3311A-Q	TRANSISTOR	[M]	L552	ELEXT101KA9	COIL	[M]
		DIODE(S)		L601	ELEXT1R0KA9	COIL	[M]
D101	MA4051MTA	DIODE	[M] Δ	L901	RLQA100JT-Y	COIL	[M]
D102	MA165	DIODE	[M]	L902	ELEXT1R0KA9	COIL	[M]
D301	MA165	DIODE	[M]			FILTER(S)	
D501, 502	MA183TA	DIODE	[M] Δ				
D503	MA4150M	DIODE	[M] Δ				
D504	MA4082LTA	DIODE	[M] Δ				

Ref. No.	Part No.	Part Name & Description	Remarks	Ref. No.	Part No.	Part Name & Description	Remarks
CF201	RLFFETMGD01L	CERAMIC FILTER	[M]			EARTH PLATE (S)	
CF202	RLFFETMGD01L	CERAMIC FILTER	[M]				
		OSCILLATOR (S)		E801, 602	SNE1004-2	EARTH PLATE	[M]
						JACK (S)	
X101	RSXZ456KM07M	OSCILLATOR	[M]				
X102	RLFDGT05DD	OSCILLATOR	[M]	JK101	RJH5210M	FM/AM ANT	[M]
X103	RSXC7M20S05T	OSCILLATOR	[M]	JK202	SJF3069-5N	EXT IN/OUT	[M]
X551	RSXZ456KM07M	OSCILLATOR	[M]				
X552	RVCST4R00MT	OSCILLATOR	[M]			CABINET AND CHASSIS	
X901	RSXC4M19S02T	OSCILLATOR	[M]				
		DISPLAY TUBE (S)		1	RGK0817-M	SIDE PANEL (L)	[M]
				2	RGK0818-M	SIDE PANEL (R)	[M]
FL901	RSL0225-F	DISPLAY TUBE	[M]	3	RHD30073-K	SCREW	[M]
		FM FRONT END(S)		4	RKM0327-S	CABINET	[M]
				5	XTB3+8JFZ	SCREW	[M]
Z120	RAL0019	FM FRONT END	[M]	6	REZ0883	FFC (14P)	[M]
		SWITCH (ES)		7	REZ0944	FFC (23P)	[M]
				8	RGRO242B-C	REAR PANEL	[M]
S901-910	EVQ21405R	SW	[M]	9	RMC0313	TUNER EARTH SPRING	[M]
		RELAY (S)		10	RFKJTHD7-N	BOTTOM CHASSIS ASS'Y	[M]
				10-1	RKA0076-N	FOOT	[M]
RL601	RSY0017M-0	RELAY	[M] Δ	11	RMN0203	P. C. B. HOLDER	[M]
		CONNECTOR (S) AND SOCKET (S)		12	RMN0195	FL HOLD PIECE	[M]
				13	RMN0381	FL HOLDER	[M]
CN101A	RJT057W007-1	CONNECTOR (7P)	[M]	14	RFKGTHD70E-N	FRONT PANEL ASS'Y	[M]
CN101B	RJU057W007	SOCKET (7P)	[M]	15	RGK0819-N	SIDE ORNAMENT (L)	[M]
CN102A	RJT057W007-1	CONNECTOR (7P)	[M]	16	RGK0820-N	SIDE ORNAMENT (R)	[M]
CN102B	RJU057W007	SOCKET (7P)	[M]	17	RGU1394A-S	BUTTON	[M]
CN103A	RJT057W007-1	CONNECTOR (7P)	[M]	18	XTBS26+8J	SCREW	[M]
CN103B	RJU057W007	SOCKET (7P)	[M]	19	SHE170-2	P. C. B. SUPPORT	[M]
CN104A	RJT057W007-1	CONNECTOR (7P)	[M]	20	XTBS3+8JFZ1	SCREW	[M]
CN104B	RJU057W007	SOCKET (7P)	[M]	21	XTB3+12JFZ	SCREW	[M]
CN105	RJU057W007	SOCKET (7P)	[M]				
CN502A	RJT057W007-1	CONNECTOR (7P)	[M]				
CN502B	RJU057W007	SOCKET (7P)	[M]				
CN901A	RJS1A6823	CONNECTOR (23P)	[M]				
CN901B	RJS1A6223-1	CONNECTOR (23P)	[M]				
CN902A	RJS1A6814	CONNECTOR (14P)	[M]				
CN902B	RJS1A6214-1	CONNECTOR (14P)	[M]				
CN904A	RJT066H05A	CONNECTOR (5P)	[M]				
CN904B	RJU066H05	SOCKET (5P)	[M]				
CP105	RJT057W007-1	CONNECTOR (7P)	[M]				
JK601	RJT065K15	CONNECTOR (15P)	[M]				
JK602	RJT065K19	CONNECTOR (19P)	[M]				
JK603	RJT065K20	CONNECTOR (20P)	[M]				

Cabinet Parts Location

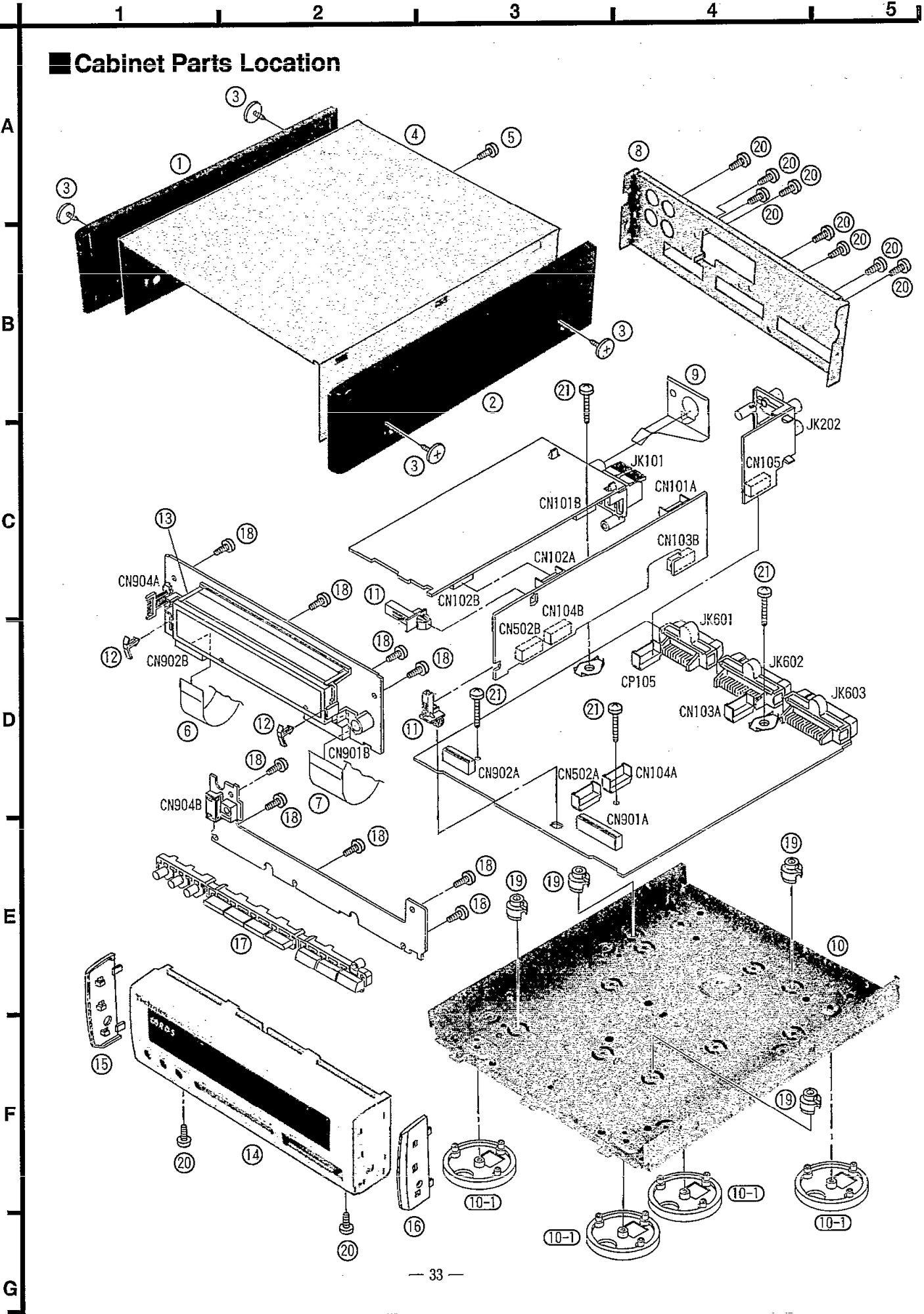

Replacement Parts List

Notes: * [M] indicates in Remarks columns parts that are supplied by MESA.							
Ref. No.	Part No.	Part Name & Description	Remarks	Ref. No.	Part No.	Part Name & Description	Remarks
		PACKING MATERIAL					
P1	RPG3297	PACKING CASE	[M]				
P2	RPN0971	CUSHION	[M]				
P3	SPP740	PROTECTION BAG	[M]				

Packaging

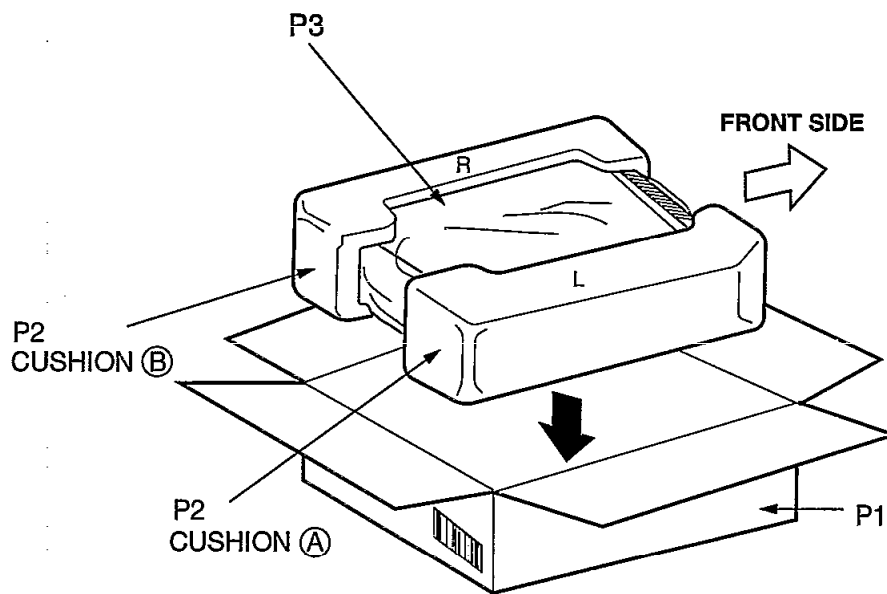

(CUSHION (A),(B) : RPN0970)

MEMO

080