

POWER AMPLIFIER

KAC-849

SERVICE MANUAL

KENWOOD

© 2001-3 PRINTED IN KOREA
B51-7762-00 (K) 3579

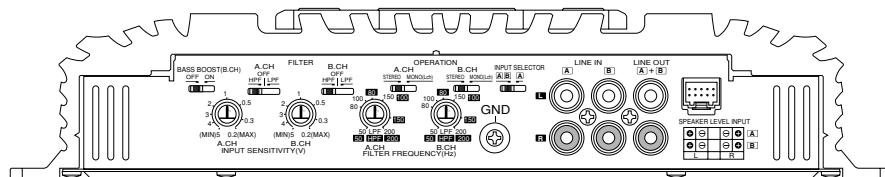
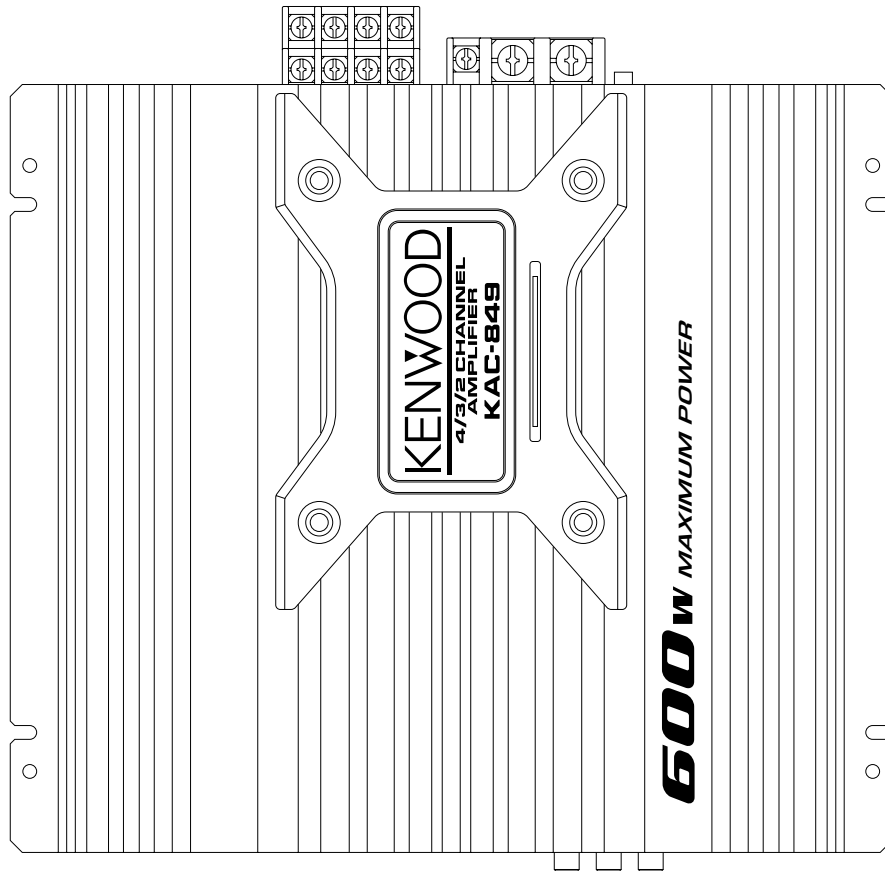
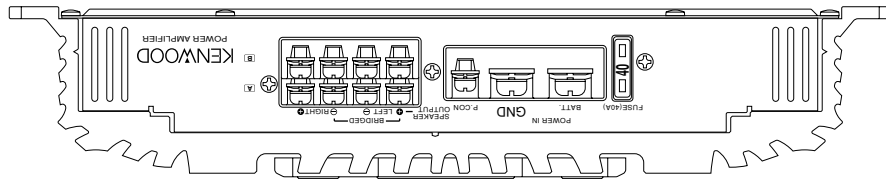

KAC-849

ADJUSTMENT

No.	ITEM	INPUT SETTINGS	OUTPUT SETTINGS	RECEIVER SETTINGS	ALIGNMENT POINTS	ALIGN FOR	FIG.
Connect a cassette receiver or CD receiver.							
1	IDEL CURRENT	-	Connect a DC voltmeter between TP1/TP2 and J3 (SP.OUT, L+/R-)	VOLUME : 0	(A) VR5 (L ch) VR6 (R ch) (B) VR7 (L ch) VR8 (R ch) (X09-)	(Normal) 2.5mV (Limit) 1.0-4.0mV	(a)

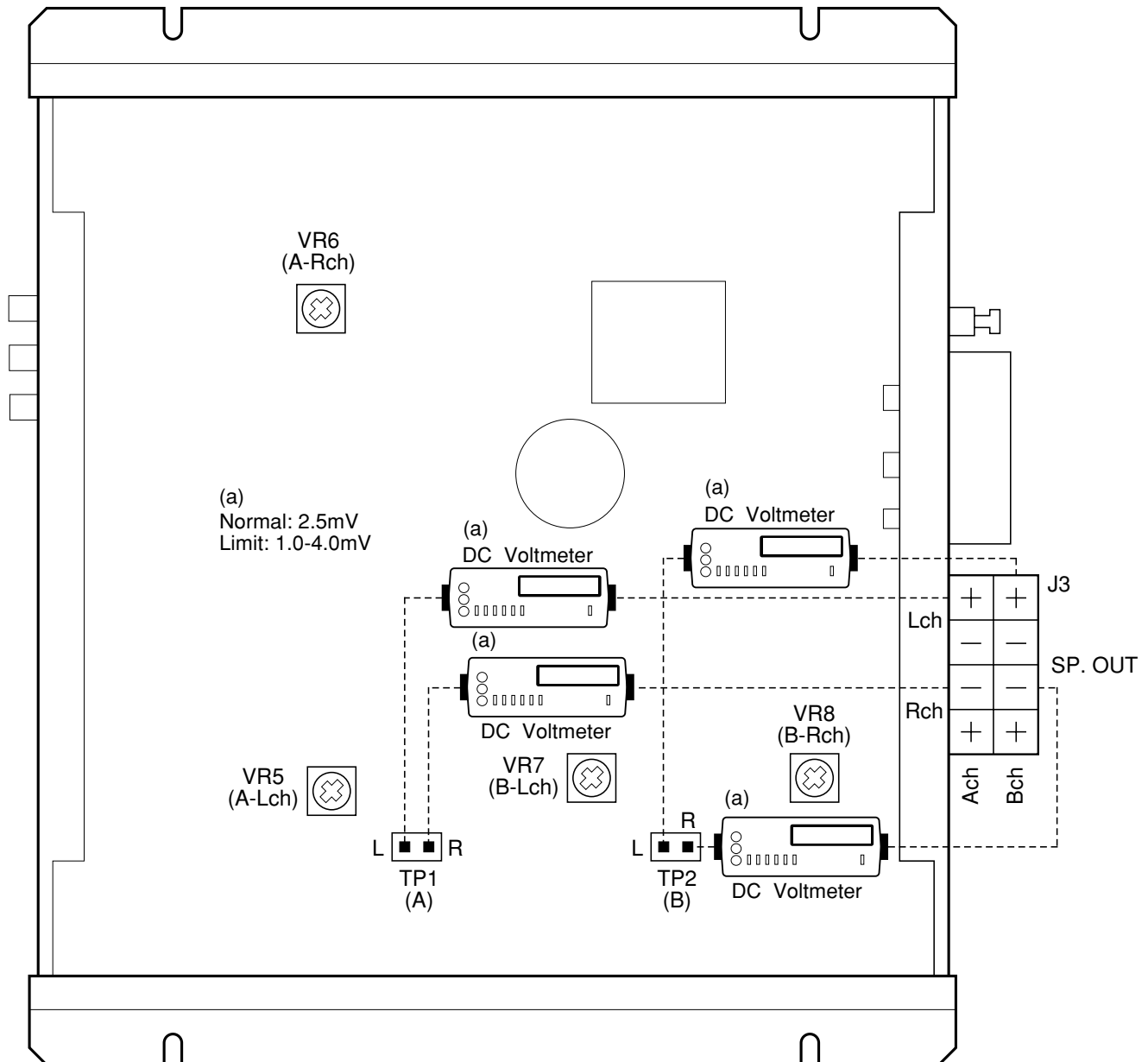

(X09-53xx-xx)		UNIT		R41, 42	R51-54, 61-64	R153,154,165,166, 253,254,265,266	Q115,116, 215,216	Q117,118, 217,218	C11,12	CN1	D13	L2
MODEL NAME	70-10	YES	NO	22 (1/2W)	430	30K	2SC5100 LB	2SA1908 LB	3900u32	NO	B30-1460-05	L19-0702-05
	KAC-749S	NO	YES	33 (1/2W)	680	43K	2SC5101 LB #5	2SA1909 LB #5	4700u35	E40-3246-05	B30-1613-05	L19-0701-05
	KAC-849	NO	YES	33 (1/2W)	680	43K	2SC5101 LB #5	2SA1909 LB #5	4700u35	E40-3246-05	B30-1613-05	L19-0701-05

AUDIO UNIT (X09-53xx-xx) (A/2)

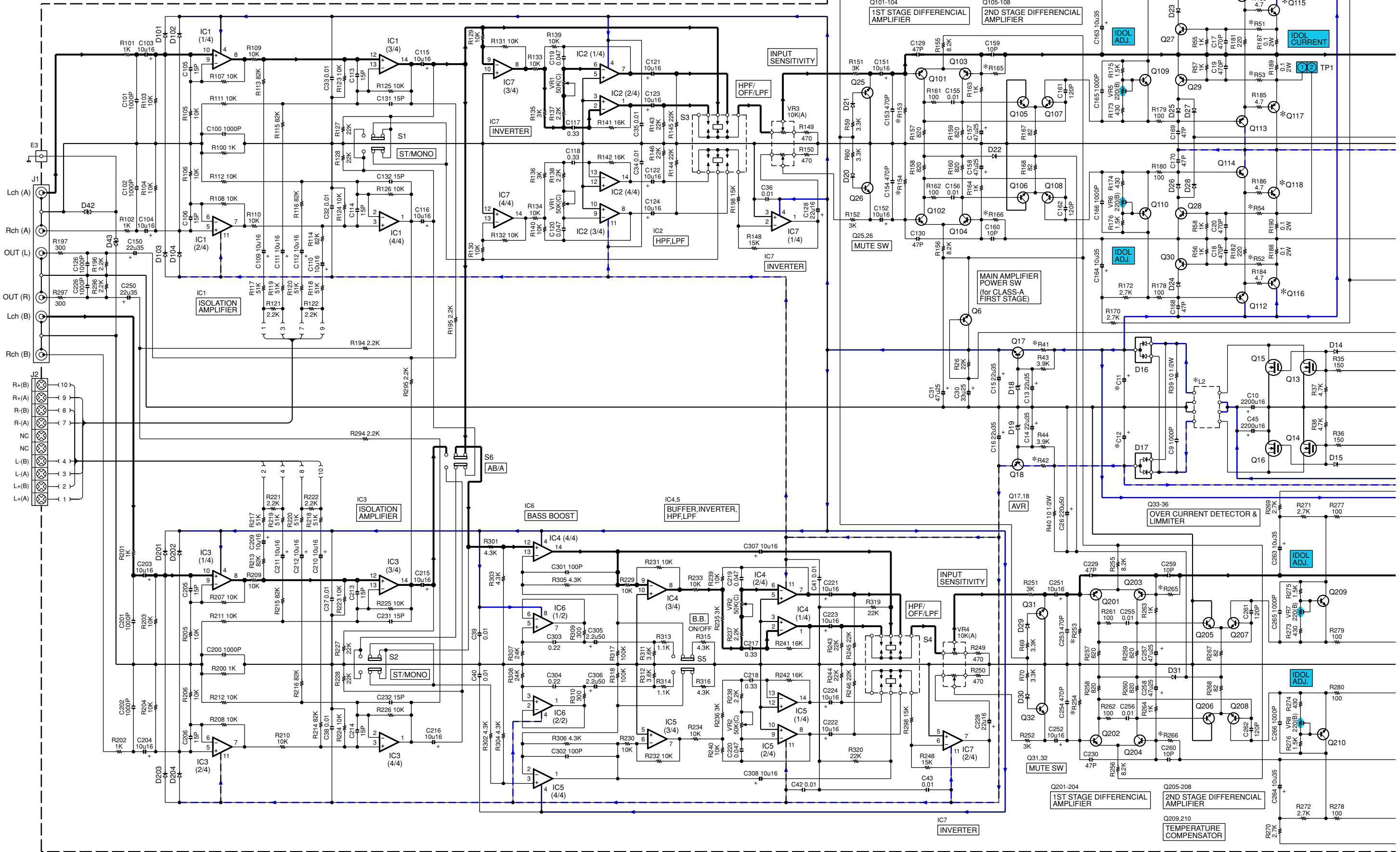

CAUTION: For continued safety, replace safety critical components only with manufacturer's recommended parts (refer to parts list). Δ indicates safety critical components. For continued protection against risk of fire, replace only with same type and rating fuse(s). To reduce the risk of electric shock, leakage-current or resistance measurements shall be carried out (exposed parts are acceptably insulated from the supply circuit) before the appliance is returned to the customer.

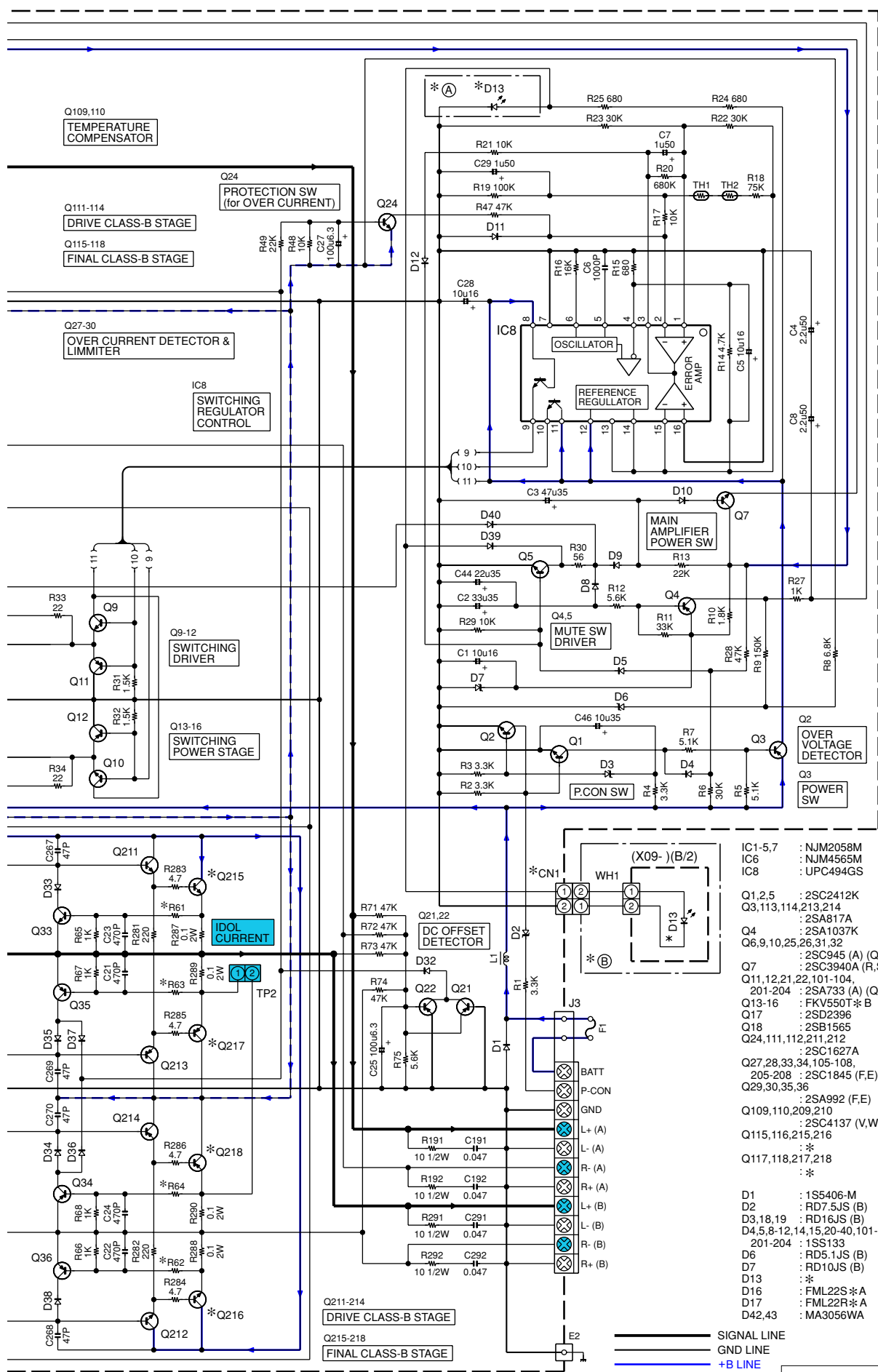

- 2SA733(A)
- 2SA817A
- 2SA992
- 2SC1627A
- 2SC1845
- 2SC3940A
- 2SC945(A)

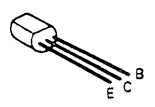

- 2SB1565
- 2SD2396

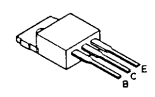

- 2SC2412K

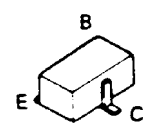

- 2SC4137



- 2SA1037K

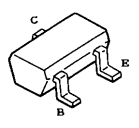

- IC1-5,7 : NJM2058M
- IC6 : NJM4565M
- IC8 : UPC494GS
- Q1,2,5 : 2SC2412K
- Q3,113,114,213,214 : 2SA817A
- Q4 : 2SA1037K
- Q6,9,10,25,26,31,32 : 2SC945 (A) (Q,P)
- Q7 : 2SC3940A (R,S)
- Q11,12,21,22,101-104, 201-204 : 2SA733 (A) (Q,P)
- Q13-16 : FKV550T*B
- Q17 : 2SD2396
- Q18 : 2SB1565
- Q24,111,112,211,212 : 2SC1627A
- Q27,28,33,34,105-108, 205-208 : 2SC1845 (F,E)
- Q29,30,35,36 : 2SA992 (F,E)
- Q109,110,209,210 : 2SC4137 (V,W)
- Q115,116,215,216 : *
- Q117,118,217,218 : *
- D1 : 1S5406-M
- D2 : RD7.5JS (B)
- D3,18,19 : RD16JS (B)
- D4,5,8-12,14,15,20-40,101-104, 201-204 : 1SS133
- D6 : RD5.1JS (B)
- D7 : RD10JS (B)
- D13 : *
- D16 : FML22S*A
- D17 : FML22R*A
- D42,43 : MA3056WA

- NJM4565M

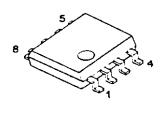

- UPC494GS

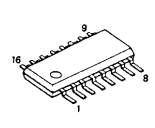

- NJM2058M

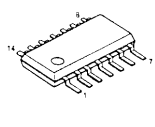

- Q211-214 : DRIVE CLASS-B STAGE
- Q215-218 : FINAL CLASS-B STAGE

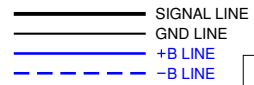

KAC-849 (J,E,K,M)

KAC-849

KENWOOD

KAC-849

EXPLODED VIEW

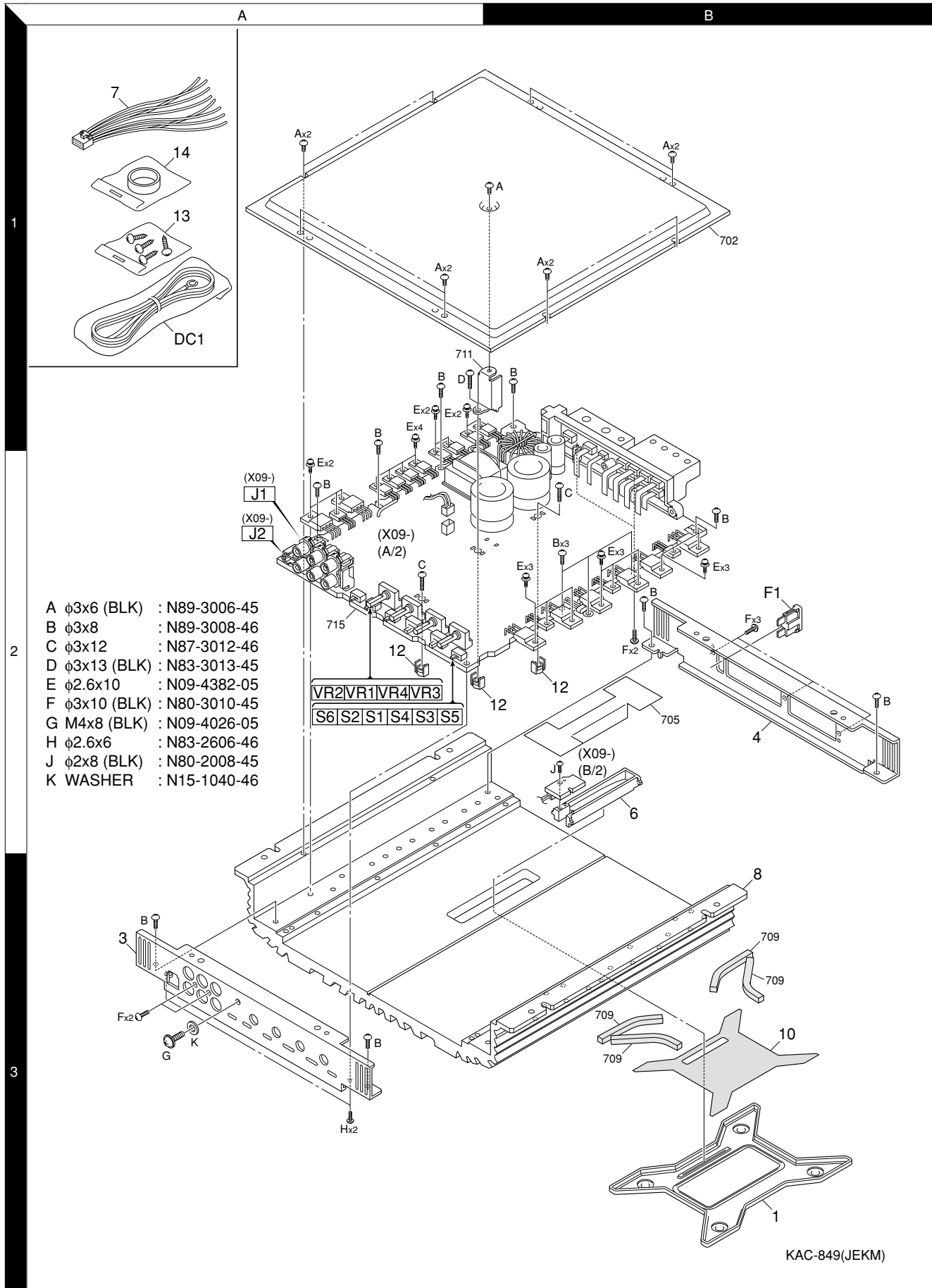

Parts with exploded view numbers larger than 700 are not supplied.

PARTS LIST

* New Parts
Parts without Part No. are not supplied.

Ref. No.	A d d	N e w	Parts No.	Description	Desti- nation
KAC-849					
1	3B	*	A21-4089-02	DRESSING PANEL	
3	3A	*	A64-2334-02	FRONT PANEL	
4	2B	*	A84-0280-02	REAR PANEL	
6	2B	*	B19-2083-03	LIGHTING BOARD	
-			B46-0100-50	WARRANTY CARD	KE1M1
-		*	B64-1969-00	INST. MANUAL (ENGLISH)	KE1
-		*	B64-1970-00	INST. MANUAL (FRENCH,SPANISH)	KE1
-		*	B64-1971-00	INST. MANUAL (GERMAN,DUTCH)	E1
-		*	B64-1972-00	INST. MANUAL (ITA,POR)	E1
-		*	B64-1973-00	INST. MANUAL (ENGLISH,CHINESE)	M1
7	1A	*	E30-4949-05	CONNECTING CORD ASSY	
8	3B	*	F01-1660-01	HEAT SINK	
△ F1	2B	*	F52-0016-05	FUSE (BLADE TYPE) (40A)	
10	3B	*	H30-0542-03	ADHESIVE DOUBLE-COATED TAPE	
-			H10-4645-03	POLYSTYRENE FOAMED FIXTURE	
-			H25-0321-04	PROTECTION BAG (600X315X0.03)	
-			H25-0336-04	PROTECTION BAG (170X250X0.03)	
-		*	H54-2070-03	ITEM CARTON CASE	
12	2A		J30-1066-04	SPACER	
13	1A		N99-1587-05	SCREW SET	
A	1A		N89-3006-45	BINDING HEAD TAPTITE SCREW	
B	1A		N89-3008-46	BINDING HEAD TAPTITE SCREW	
C	2A		N87-3012-46	BRAZIER HEAD TAPTITE SCREW	
D	1A		N83-3013-45	PAN HEAD TAPTITE SCREW	
E	2B		N09-4382-05	TAPTITE SCREW (2.6X10)	
F	3A		N80-3010-45	PAN HEAD TAPTITE SCREW	
G	3A		N09-4026-05	TAPPING SCREW (4X8,TP,S)	
H	3A		N83-2606-46	PAN HEAD TAPTITE SCREW	
J	2B		N80-2008-45	PAN HEAD TAPTITE SCREW	
K	3A		N15-1040-46	FLAT WASHER	
14	1A		W01-1515-05	TERMINAL COVER SET	
AUDIO UNIT (X09-5390-10)					
D13		*	B30-1613-05	LED (BLUE)	
C1			CE04DW1C100M	ELECTRO 10UF 16WV	
C2			CE04DW1V330M	ELECTRO 33UF 35WV	
C3			CE04DW1V470M	ELECTRO 47UF 35WV	
C4			CE04DW1H2R2M	ELECTRO 2.2UF 50WV	
C5			CE04DW1C100M	ELECTRO 10UF 16WV	
C6			CF92FV1H102J	MF-C 1000PF J	
C7			CE04DW1H010M	ELECTRO 1.0UF 50WV	
C8			CE04DW1H2R2M	ELECTRO 2.2UF 50WV	
C9			CF92FV1H822J	MF-C 8200PF J	
C10			C90-2566-05	ELECTRO 2200UF 16WV	
C11,12		*	C90-5372-05	ELECTRO 4700UF 35WV	
C13-16			CE04DW1V220M	ELECTRO 22UF 35WV	
C17-24			CF92FV1H222J	MF-C 2200PF J	
C25			CE04DW0J101M	ELECTRO 100UF 6.3WV	
C26			CE04DW1H221M	ELECTRO 220UF 50WV	
C27			CE04DW0J101M	ELECTRO 100UF 6.3WV	
C28			CE04DW1C100M	ELECTRO 10UF 16WV	
C29			CE04DW1H010M	ELECTRO 1.0UF 50WV	
C30			CE04DW1E330M	ELECTRO 33UF 25WV	
C31			CE04DW1E470M	ELECTRO 47UF 25WV	
C32-43			CK73GB1H103K	CHIP C 0.010UF K	
C44			CE04DW1V220M	ELECTRO 22UF 35WV	
C45			C90-2566-05	ELECTRO 2200UF 16WV	
C46			CE04DW1E100M	ELECTRO 10UF 25WV	
C100			CF92FV1H102J	MF-C 1000PF J	
C101,102			CK73GB1H102K	CHIP C 1000PF K	
C103,104			CE04DW1C100M	ELECTRO 10UF 16WV	
C105,106			CC73GCH1H150J	CHIP C 15PF J	
C109-112			CE04DW1C100M	ELECTRO 10UF 16WV	
C113,114			CC73GCH1H150J	CHIP C 15PF J	
C115,116			CE04DW1C100M	ELECTRO 10UF 16WV	
C117,118			CK73FB1C334K	CHIP C 0.33UF K	
C119,120			CK73GB1E473K	CHIP C 0.047UF K	
C121-124			CE04DW1C100M	ELECTRO 10UF 16WV	
C126			CK73GB1H102K	CHIP C 1000PF K	
C128			CE04DW1C220M	ELECTRO 22UF 16WV	
C129,130			CC73GCH1H470J	CHIP C 47PF J	
C150			CE04DW1V220M	ELECTRO 22UF 35WV	
C151,152			CE04DW1C100M	ELECTRO 10UF 16WV	
C153,154			CC73GCH1H471J	CHIP C 470PF J	
C155,156			CF92FV1H103J	MF-C 0.010UF J	
C157,158			CE04DW1E470M	ELECTRO 47UF 25WV	
C159,160			CC45FSL1H100D	CERAMIC 10PF D	
C161,162		*	CK45FB1H121K	CERAMIC 120PF K	
C163,164			CE04DW1V100M	ELECTRO 10UF 35WV	
C165,166			CF92FV1H102J	MF-C 1000PF J	
C167-170			CC45FSL1H470J	CERAMIC 47PF J	
C191,192			CF92FV1H473J	MF-C 0.047UF J	
C200			CF92FV1H102J	MF-C 1000PF J	
C201,202			CK73GB1H102K	CHIP C 1000PF K	
C203,204			CE04DW1C100M	ELECTRO 10UF 16WV	
C205,206			CC73GCH1H150J	CHIP C 15PF J	
C209-212			CE04DW1C100M	ELECTRO 10UF 16WV	
C213,214			CC73GCH1H150J	CHIP C 15PF J	
C215,216			CE04DW1C100M	ELECTRO 10UF 16WV	
C217,218			CK73FB1C334K	CHIP C 0.33UF K	
C219,220			CK73GB1E473K	CHIP C 0.047UF K	
C221-224			CE04DW1C100M	ELECTRO 10UF 16WV	
C226			CK73GB1H102K	CHIP C 1000PF K	
C228			CE04DW1C220M	ELECTRO 22UF 16WV	
C229,230			CC73GCH1H470J	CHIP C 47PF J	
C250			CE04DW1V220M	ELECTRO 22UF 35WV	
C251,252			CE04DW1C100M	ELECTRO 10UF 16WV	
C253,254			CC73GCH1H471J	CHIP C 470PF J	
C255,256			CF92FV1H103J	MF-C 0.010UF J	
C257,258			CE04DW1E470M	ELECTRO 47UF 25WV	
C259,260			CC45FSL1H100D	CERAMIC 10PF D	

E1 : Europe J1 : Japan K : North America
M1 : Other Areas

△ indicates safety critical components.

PARTS LIST

* New Parts
Parts without Part No. are not supplied.

Ref. No.	A d d	N e w	Parts No.	Description	Desti- nation	Ref. No.	A d d	N e w	Parts No.	Description	Desti- nation
C261,262		*	CK45FB1H121K	CERAMIC 120PF K		R48			RK73GB1J103J	CHIP R 10K J 1/16W	
C263,264			CE04DW1V100M	ELECTRO 10UF 35WV		R49			RK73GB1J223J	CHIP R 22K J 1/16W	
C265,266			CF92FV1H102J	MF-C 1000PF J		R51 -54			RD14BB2C681J	RD 680 J 1/6W	
C267-270			CC45FSL1H470J	CERAMIC 47PF J		R55 -58			RD14BB2C102J	RD 1.0K J 1/6W	
C291,292			CF92FV1H473J	MF-C 0.047UF J		R59 ,60			RK73GB1J332J	CHIP R 3.3K J 1/16W	
C301,302			CC73GCH1H101J	CHIP C 100PF J		R61 -64			RD14BB2C681J	RD 680 J 1/6W	
C303,304			CF92FV1H224J	MF-C 0.22UF J		R65 -68			RD14BB2C102J	RD 1.0K J 1/6W	
C305,306			CE04DW1H2R2M	ELECTRO 2.2UF 50WV		R69 ,70			RK73GB1J332J	CHIP R 3.3K J 1/16W	
C307,308			CE04DW1C100M	ELECTRO 10UF 16WV		R71 -74			RD14BB2C473J	RD 47K J 1/6W	
CN1			E40-3246-05	PIN ASSY		R75			RD14BB2C562J	RD 5.6K J 1/6W	
E2 ,3			E23-0149-05	TERMINAL		R100			RD14BB2C102J	RD 1.0K J 1/6W	
J1	2A	*	E63-0874-05	PIN JACK		R101,102			RK73EB2B102J	CHIP R 1.0K J 1/8W	
J2	2A	*	E58-0919-05	RECTANGULAR RECEPTACLE		R103-108			RK73GB1J103J	CHIP R 10K J 1/16W	
△ J3	1B	*	E70-0833-05	SCREW TERMINAL BOARD		R109-112			RK73FB2A103J	CHIP R 10K J 1/10W	
TP1 ,2			E40-3640-05	PIN ASSY		R113-116			RK73GB1J823J	CHIP R 82K J 1/16W	
WH1		*	E39-0408-05	WIRING HARNESS		R117-120			RK73EB2B513J	CHIP R 51K J 1/8W	
E1			J19-4316-05	HOLDER		R121,122			RD14BB2C222J	RD 2.2K J 1/6W	
L1			L33-1015-05	CHOKE COIL		R123-126			RK73FB2A103J	CHIP R 10K J 1/10W	
L2		*	L19-0701-05	TRANSFORMER FOR CONVERTER		R127,128			RK73GB1J223J	CHIP R 22K J 1/16W	
F	2B		N80-3010-45	PAN HEAD TAPTITE SCREW		R129-134			RK73GB1J103J	CHIP R 10K J 1/16W	
R1 -4			RK73GB1J332J	CHIP R 3.3K J 1/16W		R135,136			RK73GB1J302J	CHIP R 3.0K J 1/16W	
R5			RK73GB1J512J	CHIP R 5.1K J 1/16W		R137,138			RK73GB1J222J	CHIP R 2.2K J 1/16W	
R6			RK73GB1J303J	CHIP R 30K J 1/16W		R139,140			RK73GB1J103J	CHIP R 10K J 1/16W	
R7			RK73GB1J512J	CHIP R 5.1K J 1/16W		R141,142			RK73GB1J163J	CHIP R 16K J 1/16W	
R8			RD14BB2C682J	RD 6.8K J 1/6W		R143-146			RK73GB1J223J	CHIP R 22K J 1/16W	
R9			RK73GB1J154J	CHIP R 150K J 1/16W		R148			RK73GB1J153J	CHIP R 15K J 1/16W	
R10			RD14BB2C182J	RD 1.8K J 1/6W		R149,150			RK73GB1J471J	CHIP R 470 J 1/16W	
R11			RK73GB1J333J	CHIP R 33K J 1/16W		R151,152			RK73GB1J302J	CHIP R 3.0K J 1/16W	
R12			RK73GB1J562J	CHIP R 5.6K J 1/16W		R153,154			RK73GB1J433J	CHIP R 43K J 1/16W	
R13			RD14BB2C223J	RD 22K J 1/6W		R155,156			RD14BB2C822J	RD 8.2K J 1/6W	
R14			RK73GB1J472J	CHIP R 4.7K J 1/16W		R157-160			RD14BB2C821J	RD 820 J 1/6W	
R15			RK73GB1J681J	CHIP R 680 J 1/16W		R161,162			RD14BB2C101J	RD 100 J 1/6W	
R16			RK73GB1J163J	CHIP R 16K J 1/16W		R163,164			RD14BB2C102J	RD 1.0K J 1/6W	
R17			RK73GB1J103J	CHIP R 10K J 1/16W		R165,166			RD14BB2C433J	RD 43K J 1/6W	
R18			RK73GB1J753J	CHIP R 75K J 1/16W		R167,168			RD14BB2C820J	RD 82 J 1/6W	
R19			RK73GB1J104J	CHIP R 100K J 1/16W		R169-172			RD14BB2C272J	RD 2.7K J 1/6W	
R20			RK73GB1J684J	CHIP R 680K J 1/16W		R173,174			RD14BB2C431J	RD 430 J 1/6W	
R21			RK73GB1J103J	CHIP R 10K J 1/16W		R175,176			RD14BB2C152J	RD 1.5K J 1/6W	
R22 ,23			RK73GB1J303J	CHIP R 30K J 1/16W		R177-180			RD14NB2E101J	RD 100 J 1/4W	
R24 ,25			RD14BB2C681J	RD 680 J 1/6W		R181,182			RD14NB2E221J	RD 220 J 1/4W	
R26 ,27			RD14BB2C223J	RD 22K J 1/6W		R183-186			RD14NB2E4R7J	RD 4.7 J 1/4W	
R28			RD14BB2C473J	RD 47K J 1/6W		R187-190			R92-0205-05	METAL-PLATE 0.1 K 2W	
R29			RK73GB1J103J	CHIP R 10K J 1/16W		R191,192			RD14DB2H100J	SMALL-RD 10 J 1/2W	
R30			RD14BB2C560J	RD 56 J 1/6W		R194-196			RK73GB1J222J	CHIP R 2.2K J 1/16W	
R31 ,32			RD14BB2C152J	RD 1.5K J 1/6W		R197			RK73EB2B301J	CHIP R 300 J 1/8W	
R33 ,34			RD14BB2C220J	RD 22 J 1/6W		R198			RK73GB1J153J	CHIP R 15K J 1/16W	
R35 ,36			RD14BB2C151J	RD 150 J 1/6W		R200			RD14BB2C102J	RD 1.0K J 1/6W	
R37 ,38			RD14BB2C472J	RD 4.7K J 1/6W		R201,202			RK73EB2B102J	CHIP R 1.0K J 1/8W	
R39 ,40			RD14DB2H100J	SMALL-RD 10 J 1/2W		R203-208			RK73GB1J103J	CHIP R 10K J 1/16W	
R41 ,42			RD14DB2H330J	SMALL-RD 33 J 1/2W		R209-212			RK73FB2A103J	CHIP R 10K J 1/10W	
R43 ,44			RD14BB2C392J	RD 3.9K J 1/6W		R213-216			RK73GB1J823J	CHIP R 82K J 1/16W	
R47			RK73GB1J473J	CHIP R 47K J 1/16W		R217-220			RK73EB2B513J	CHIP R 51K J 1/8W	
						R221,222			RD14BB2C222J	RD 2.2K J 1/6W	
						R223-226			RK73FB2A103J	CHIP R 10K J 1/10W	
						R227,228			RK73GB1J223J	CHIP R 22K J 1/16W	

E1 : Europe J1 : Japan K : North America
M1 : Other Areas

△ indicates safety critical components.

PARTS LIST

* New Parts
Parts without Part No. are not supplied.

Ref. No.	A d d	N e w	Parts No.	Description	Desti- nation	Ref. No.	A d d	N e w	Parts No.	Description	Desti- nation
R229-234			RK73GB1J103J	CHIP R 10K J 1/16W		D18 ,19			RD16JS(B)	ZENER DIODE	
R235,236			RK73GB1J302J	CHIP R 3.0K J 1/16W		D20 -40			1SS133	DIODE	
R237,238			RK73GB1J222J	CHIP R 2.2K J 1/16W		D42 ,43			MA3056WA	ZENER DIODE	
R239,240			RK73GB1J103J	CHIP R 10K J 1/16W		D101-104			1SS133	DIODE	
R241,242			RK73GB1J163J	CHIP R 16K J 1/16W		D201-204			1SS133	DIODE	
R243-246			RK73GB1J223J	CHIP R 22K J 1/16W		IC1 -5			NJM2058M	IC(OP AMP)	
R248			RK73GB1J153J	CHIP R 15K J 1/16W		IC6			NJM4565M	ANALOGUE IC	
R249,250			RK73GB1J471J	CHIP R 470 J 1/16W		IC7			NJM2058M	IC(OP AMP)	
R251,252			RK73GB1J302J	CHIP R 3.0K J 1/16W		IC8			UPC494GS	ANALOGUE IC	
R253,254			RK73GB1J433J	CHIP R 43K J 1/16W		Q1 ,2			2SC2412K	TRANSISTOR	
R255,256			RD14BB2C822J	RD 8.2K J 1/6W		Q3			2SA817A	TRANSISTOR	
R257-260			RD14BB2C821J	RD 820 J 1/6W		Q4			2SA1037K	TRANSISTOR	
R261,262			RD14BB2C101J	RD 100 J 1/6W		Q5			2SC2412K	TRANSISTOR	
R263,264			RD14BB2C102J	RD 1.0K J 1/6W		Q6			2SC945(A)(Q,P)	TRANSISTOR	
R265,266			RD14BB2C433J	RD 43K J 1/6W		Q7			2SC3940A(R,S)	TRANSISTOR	
R267,268			RD14BB2C820J	RD 82 J 1/6W		Q9 ,10			2SC945(A)(Q,P)	TRANSISTOR	
R269-272			RD14BB2C272J	RD 2.7K J 1/6W		Q11 ,12			2SA733(A)(Q,P)	TRANSISTOR	
R273,274			RD14BB2C431J	RD 430 J 1/6W		Q13 -16			FKV550T*B	FET	
R275,276			RD14BB2C152J	RD 1.5K J 1/6W		Q17			2SD2396	TRANSISTOR	
R277-280			RD14NB2E101J	RD 100 J 1/4W		Q18			2SB1565	TRANSISTOR	
R281,282			RD14NB2E221J	RD 220 J 1/4W		Q21 ,22			2SA733(A)(Q,P)	TRANSISTOR	
R283-286			RD14NB2E4R7J	RD 4.7 J 1/4W		Q24			2SC1627A	TRANSISTOR	
R287-290			R92-0205-05	METAL-PLATE 0.1 K 2W		Q25 ,26			2SC945(A)(Q,P)	TRANSISTOR	
R291,292			RD14DB2H100J	SMALL-RD 10 J 1/2W		Q27 ,28			2SC1845(F,E)	TRANSISTOR	
R294-296			RK73GB1J222J	CHIP R 2.2K J 1/16W		Q29 ,30			2SA992(F,E)	TRANSISTOR	
R297			RK73EB2B301J	CHIP R 300 J 1/8W		Q31 ,32			2SC945(A)(Q,P)	TRANSISTOR	
R298			RK73GB1J153J	CHIP R 15K J 1/16W		Q33 ,34			2SC1845(F,E)	TRANSISTOR	
R301-306			RK73GB1J432J	CHIP R 4.3K J 1/16W		Q35 ,36			2SA992(F,E)	TRANSISTOR	
R307,308			RK73GB1J243J	CHIP R 24K J 1/16W		Q101-104			2SA733(A)(Q,P)	TRANSISTOR	
R309,310			RK73GB1J301J	CHIP R 300 J 1/16W		Q105-108			2SC1845(F,E)	TRANSISTOR	
R311,312			RK73GB1J362J	CHIP R 3.6K J 1/16W		Q109,110			2SC4137(V,W)	TRANSISTOR	
R313,314			RK73GB1J112J	CHIP R 1.1K J 1/16W		Q111,112			2SC1627A	TRANSISTOR	
R315,316			RK73GB1J432J	CHIP R 4.3K J 1/16W		Q11s,114			2SA817A	TRANSISTOR	
R317,318			RK73GB1J104J	CHIP R 100K J 1/16W		Q115,116			2SC5101LB*5	TRANSISTOR	
R319,320			RK73GB1J223J	CHIP R 22K J 1/16W		Q117,118			2SA1909LB*5	TRANSISTOR	
R401-440			RD14BB2E221J	RD 220 J 1/4W		Q201-204			2SA733(A)(Q,P)	TRANSISTOR	
VR1 ,2			R31-0215-05	VARIABLE RESISTOR		Q205-208			2SC1845(F,E)	TRANSISTOR	
VR3 ,4		*	R31-0232-05	VARIABLE RESISTOR		Q209,210			2SC4137(V,W)	TRANSISTOR	
VR5 -8			R32-0030-05	SEMI FIXED VARIABLE RESISTOR		Q211,212			2SC1627A	TRANSISTOR	
W351-395			R92-1252-05	CHIP R 0 OHM		Q213,214			2SA817A	TRANSISTOR	
S1 ,2			S62-0842-05	SLIDE SWITCH		Q215,216			2SC5101LB*5	TRANSISTOR	
S3 ,4			S31-2630-05	SLIDE SWITCH		Q217,218			2SA1909LB*5	TRANSISTOR	
S5 ,6			S62-0842-05	SLIDE SWITCH		TH1			PTH9L04BD222TS	POSITIVE RESISTOR	
D1			1N5406-M	DIODE		TH2			PTH9M04BD222T	POSITIVE RESISTOR	
D2			RD7.5JS(B)	ZENER DIODE							
D3			RD16JS(B)	ZENER DIODE							
D4 ,5			1SS133	DIODE							
D6			RD5.1JS(B)	ZENER DIODE							
D7			RD10JS(B)	ZENER DIODE							
D8 -12			1SS133	DIODE							
D14 ,15			1SS133	DIODE							
D16			FML22S*A	DIODE							
D17			FML22R*A	DIODE							

E1 : Europe J1 : Japan K : North America
M1 : Other Areas

△ indicates safety critical components.

KAC-849

SPECIFICATIONS

Audio Section

Rated Power Output (4 Ω)	
A, B Channel (20-20KHz, 0.08% THD).....	50W x 4
A, B Channel (DIN45324, +B=14.4V)	50W x 4
Rated Power Output (2 Ω)	
A, B Channel (1KHz, 0.8% THD)	75W x 4
Bridged Power Output (4 Ω , 1KHz, 0.8% THD)	150W x 2
Max Power Output (4 Ω , Normal)	100W x 4
Max Power Output (4 Ω , Bridge)	300W x 2
Low Pass Filter (A, B channel, 12dB/oct.)	50Hz - 200Hz
High Pass Filter (A, B channel, 12dB/oct.)	50Hz - 200Hz
Bass Boost Circuit (90Hz)	0.6dB
Frequency Response (+0, -3dB)	5Hz - 50KHz
Signal to Noise Ratio	100dB
Sensitivity (Max) (rated output)	0.2V
Sensitivity (Min) (rated output)	5.0V
Input Impedance	10K Ω

General

Operating Voltage (11V-16V allowable)	14.4V
Current Consumption (1KHz, 10% THD)	31A
Dimensions (Width x Height x Depth)	261mm x 57mm x 256mm
Weight	3.5Kg