

SECTION 6. SPEAKER PART

MODEL: FE-DV25TE

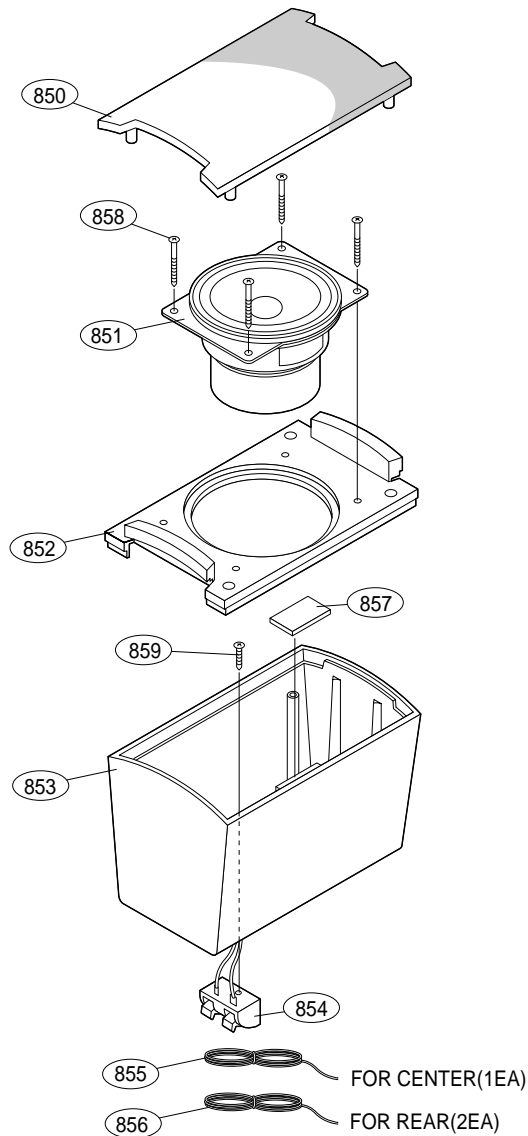

(Regional Code) FE-DV25TE

LGEMS , MEXICO /LGESA , SOUTH AFRICA /LGEFS , FRANCE /LGEPL , POLAND

LGEDG , GERMANY /LGEMK , HUNGARY /LGEIS , ITALY /LGEES , SPAIN

RUN DATE : 30.AUGUST.2001 NSP : Non SVC Parts

LOCA. NO.	PART NO.	DESCRIPTION	SPECIFICATION	REMARKS
850	3701RM0003B	NET ASSY	ASSY,FE-3500T(SATELLITE),ROK T	NSP
851	6400RMT001A	SPEAKER,GENERAL	F30C-D169(FE-DV25TE) TOPTONE 6	
852	3720RMF009B	PANEL,FRONT	FE-DV55SE(REAR SPK)	NSP
853	3110RM0005B	CASE	FE-DV55SE(REAR SPK)	NSP
854	6871RU4116A	PWB(PCB) ASSY,SUBSET(AUDIO)	FE-3500SE(STANDARD) 2P TERMINA	NSP
855	6871RU4117C	PWB(PCB) ASSY,SUBSET(AUDIO)	FE-DV25TE 2P WIRE 2.5M CENTER	NSP
856	6871RU4117B	PWB(PCB) ASSY,SUBSET(AUDIO)	FE-3500SE(STANDARD) 2P WIRE 10	NSP
857	3806RM0006A	DECO	FE-3500TE PLATE	NSP
858	353M025U	SCREW,DRAWING	+ 2 D3.0 L27.0 MSWR3/FZB	
859	353M050H	SCREW,DRAWING	+ 1 D4.0 L12.0 MSWR3/FZY FE-35	

SECTION 6. SPEAKER PART

MODEL: FE-DV25VE

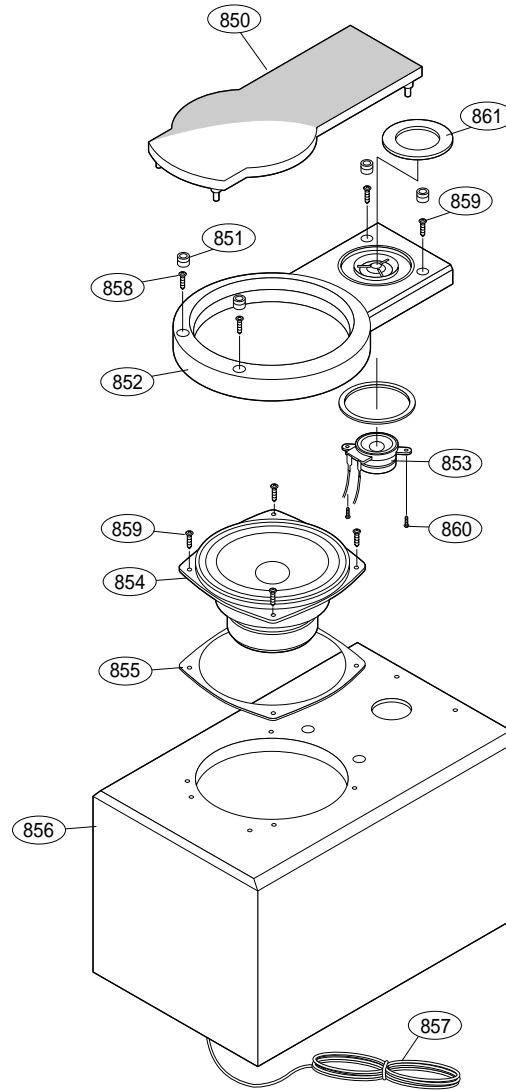

(Regional Code) FE-DV25VE

A : LGEMS , MEXICO / LGESA , SOUTH AFRICA / LGEFS , FRANCE / LGEPL , POLAND LGEMK , HUNGARY / LGEIS , ITALY / LGEES , SPAIN

B : LGEDG , GERMANY RUN DATE : 30.AUGUST.2001 NSP : Non SVC Parts

LOCA. NO.	PART NO.	A	B	DESCRIPTION	SPECIFICATION	REMARKS
850	3701RM0010B	O	O	NET ASSEMBLY	JERSEY NET ASSY FE-185E/DV25VE	NSP
851	4930RM0006A	O	O	HOLDER,SHELF	RUBBER HOLDER NET (FE-185E/DV2	NSP
852	3720RMF007A	O	O	PANEL,FRONT	FRONT (FE-185E)	NSP
853	6400RMBZ01A	O	O	SPEAKER,TWEETER	FE-DV25VE(SMS) BALHAE B13TP6B	
854	6400RMTG01A	O	O	SPEAKER,WOOFER	FE-DV55VE TOPTONE F50C-D138A 6	
855	4766RM0007A	O	O	FELT	FE-185E/DV25VE 380 BLACK WOOFE	
856	3091RMW015A	O		CABINET ASSY	ASSY FE-DV25VE	NSP
856	3091RMW015B		O	CABINET ASSEMBLY	ASSY FE-DV25VE E-1	NSP
857	6871RU4122A	O	O	PWB(PCB) ASSY,SUBSET(AUDIO)	FE-DV25VE 2.7UF POSITIVE 2M SP	NSP
858	353M052P	O	O	SCREW	BH 3.5X24	
859	353M050C	O	O	SCREW	BH 3.5X16 FBK	
860	353M050F	O	O	SCREW,DRAWING	+ 2 D3.5 L14.0 MSWR3/FZY 8X3.5	
861	3806RM0004A	O	O	DECO	DECO RING (FE-185E/DV25VE)	NSP