

BLOCK DIAGRAM

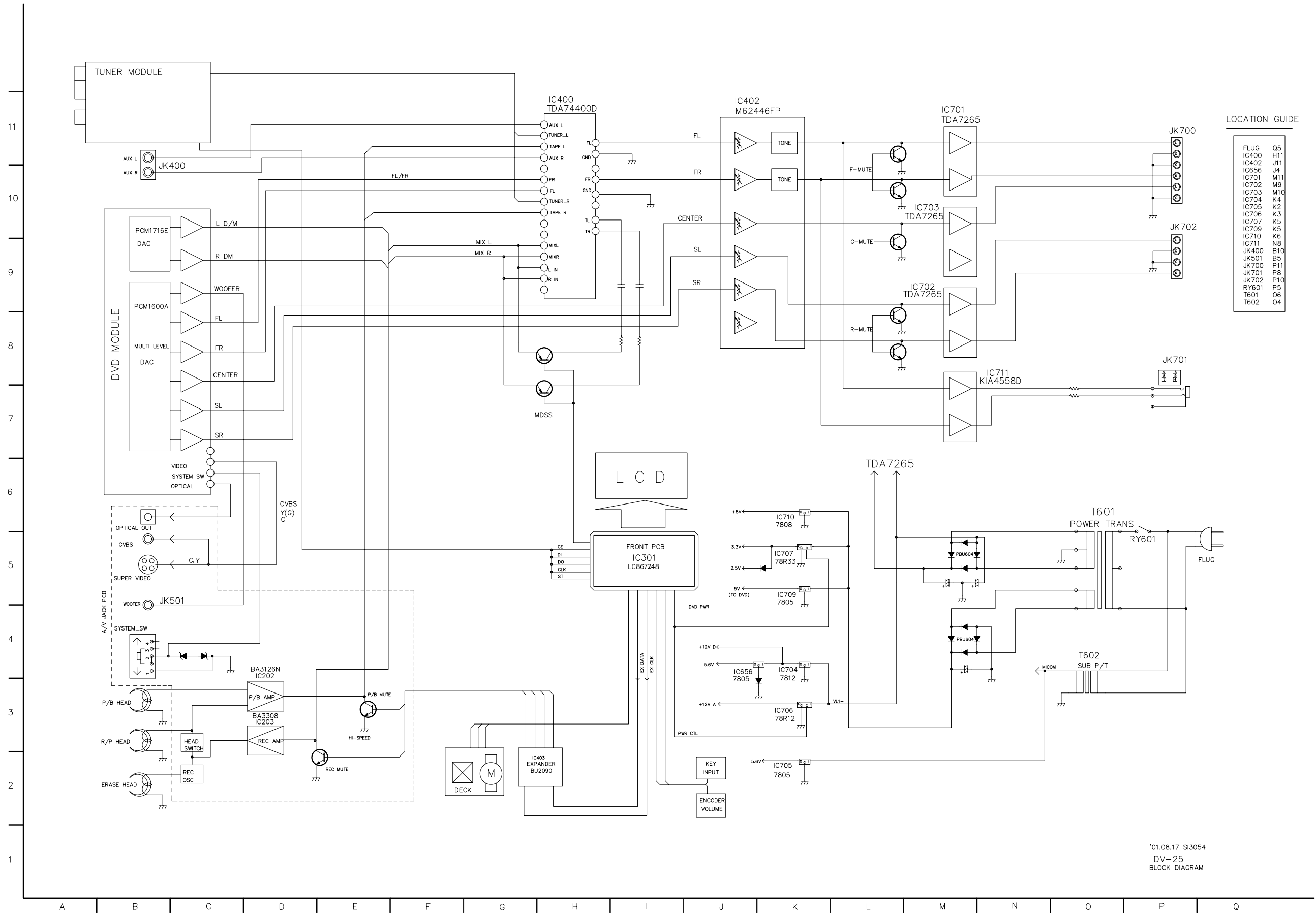

LOCATION GUIDE

FLUG	Q5
IC400	H11
IC402	J11
IC656	J4
IC701	M11
IC702	M9
IC703	M10
IC704	K4
IC705	K2
IC706	K3
IC707	K5
IC709	K5
IC710	K6
IC711	N8
JK400	B10
JK501	B5
JK700	P11
JK701	P8
JK702	P10
RY601	P5
T601	O6
T602	O4

'01.08.17 SI3054
DV-25
BLOCK DIAGRAM

BLOCK DIAGRAMS

1. RF/CD DSP/DVD DSP/DVD SERVO Block Diagram

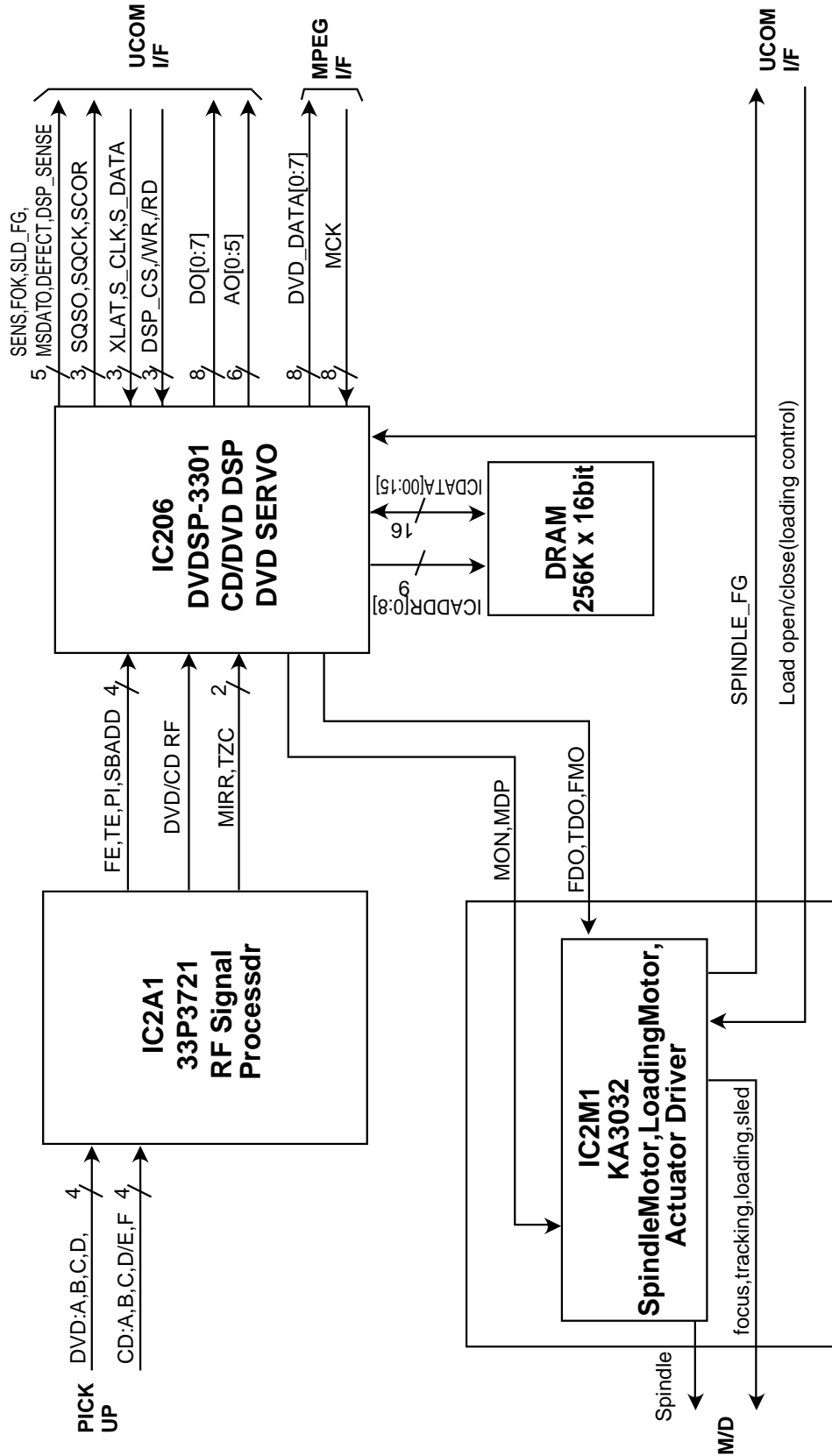

2. MPEG Block Diagram

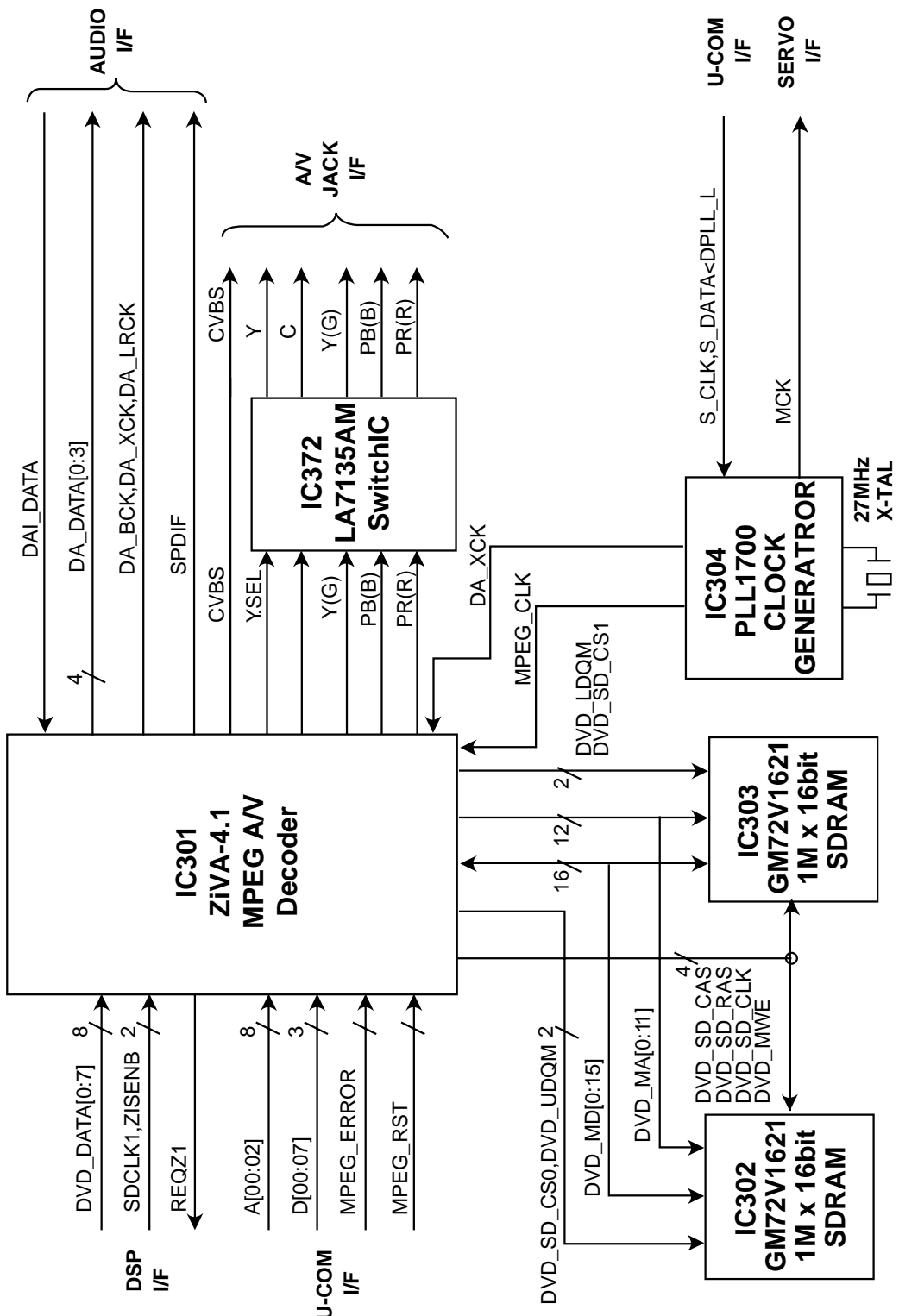

3. μ -COM Block Diagram

