

KENWOOD
HI/FI STEREO COMPONENTS

SERVICE MANUAL

KR-6170

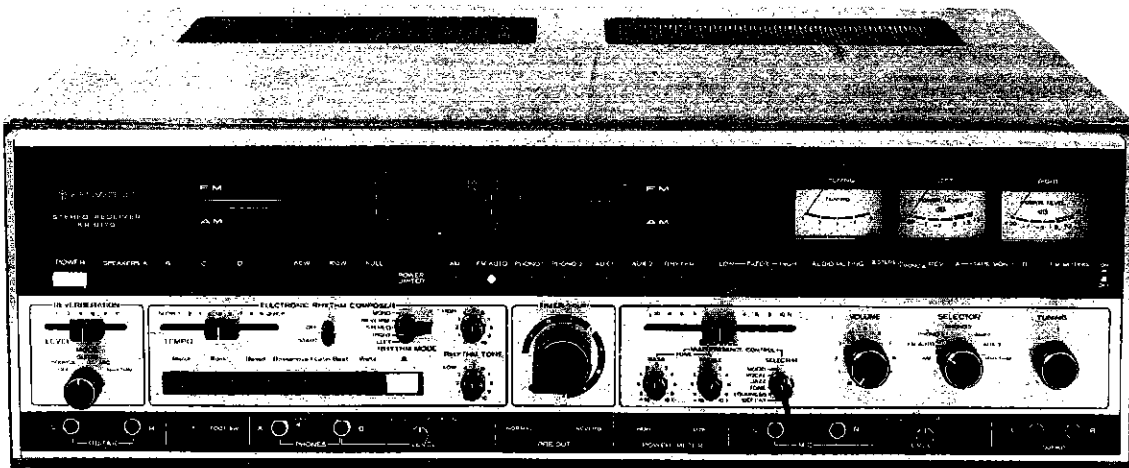

**SOLID STATE AM-FM STEREO RECEIVER
WITH ELECTRONIC RHYTHM COMPOSER**

● EXTERNAL VIEW

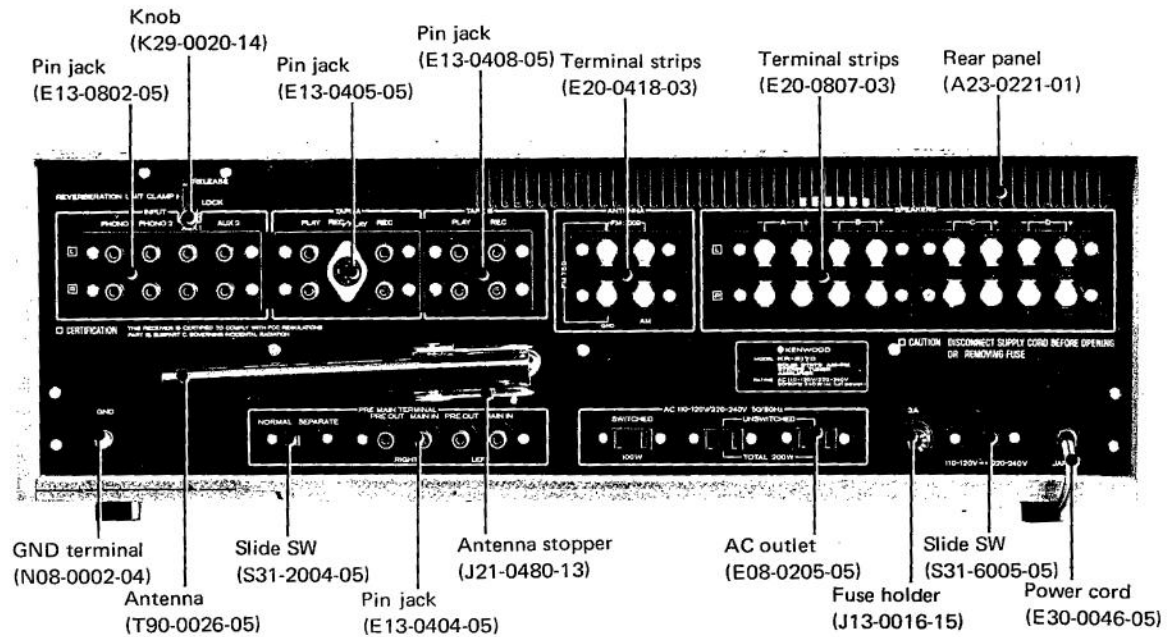
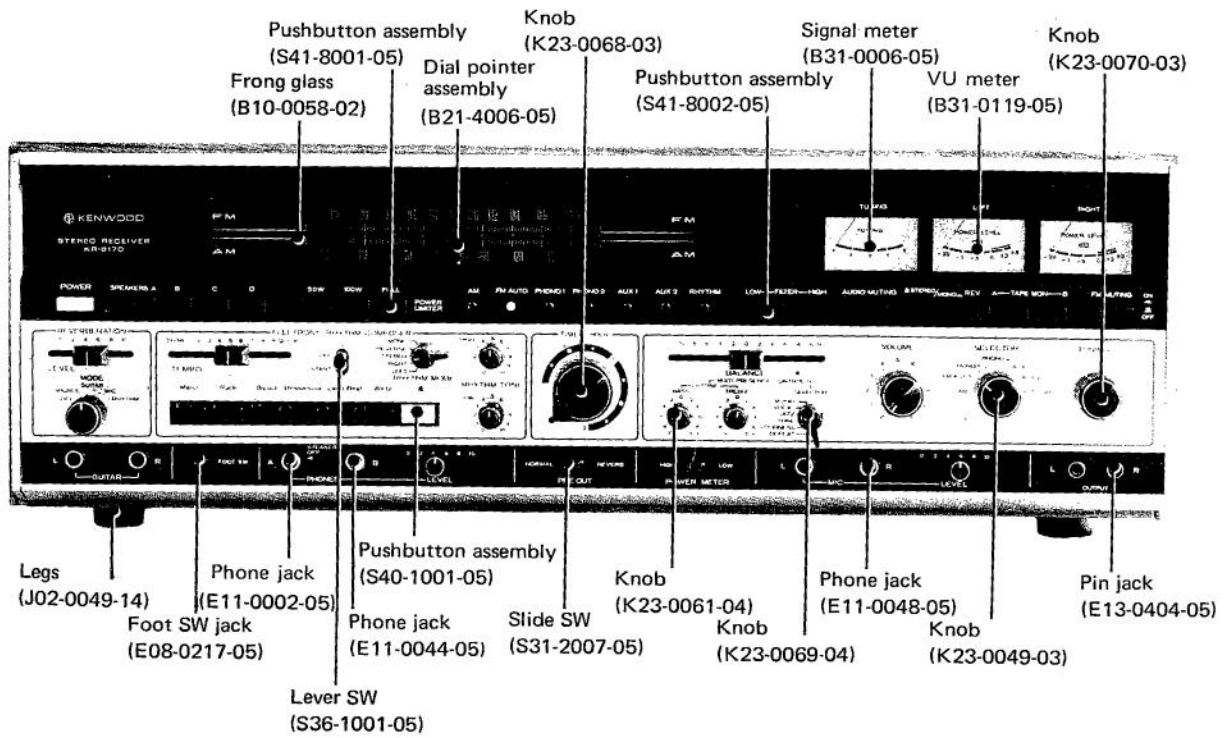

● TOP & BOTTOM CHASSIS VIEW

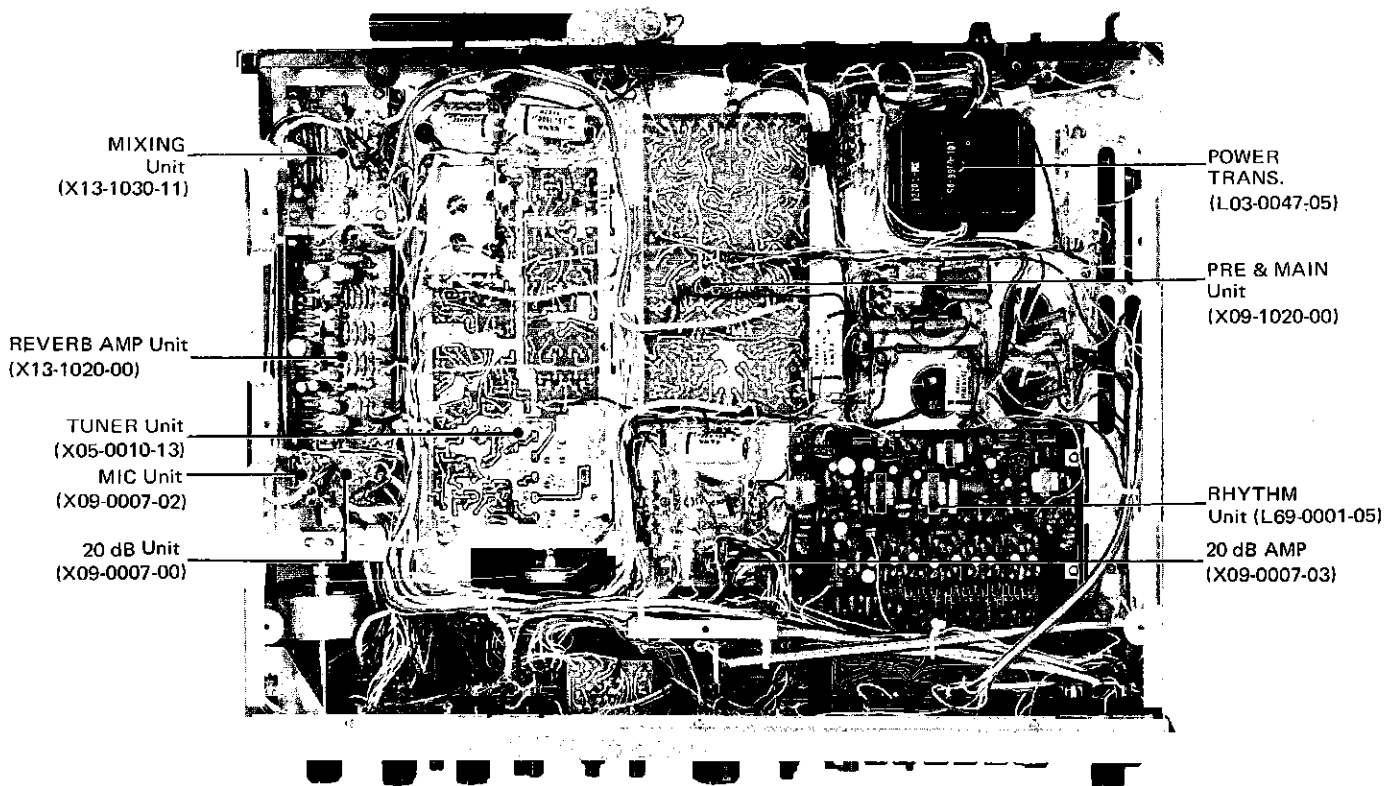
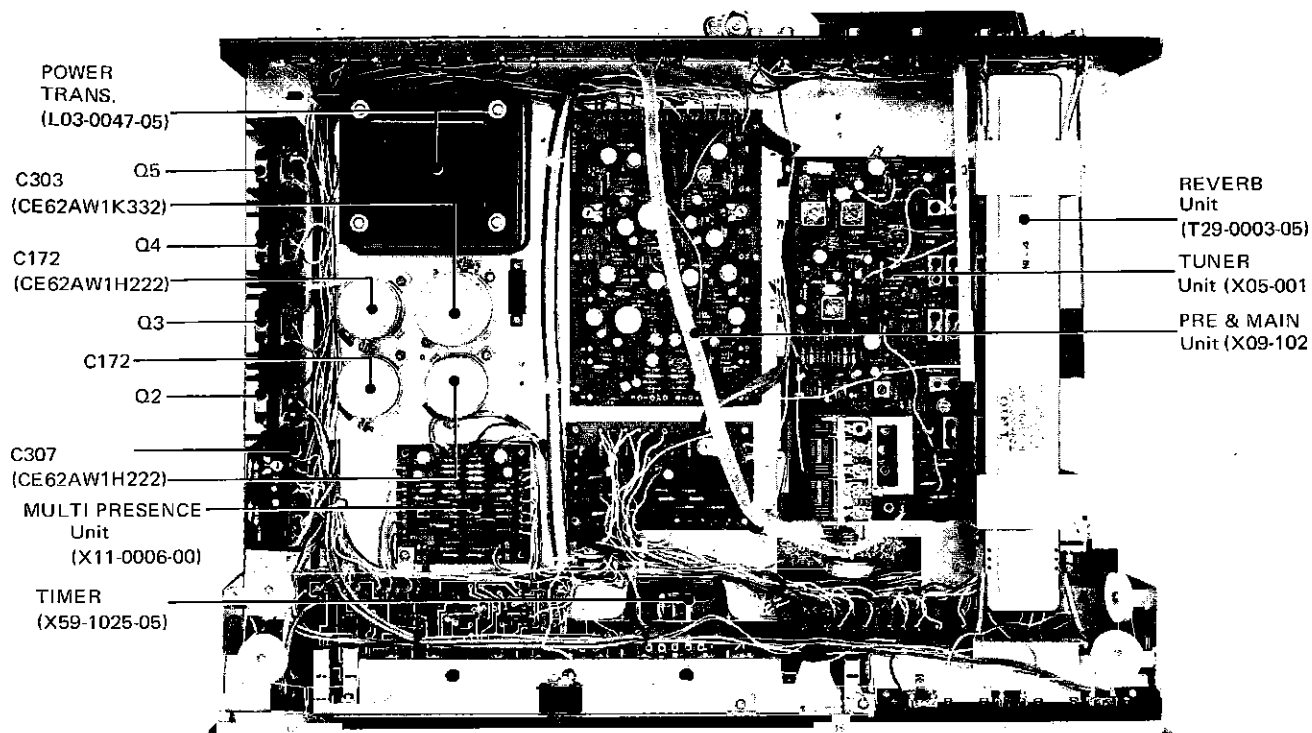

● ADJUSTMENT

■ FM-RF/IF ADJUSTMENT

STEP	ALIG.	FM SSG/SWEEP G.		TUNING DIAL SETTING	VTVM or SCOPE COUPLING	ADJUST	CHECK
		COUPLING	SIGNAL				
1	IF trans.	*FM antenna terminal or TEST POINT (A)	10.7MHz (Unmod.)	Any non-interfering setting	SCOPE to the TEST POINT (B)	(X05-0010-13) Ta3, 5 Prim. & Sec.	Maximum amplitude and symmetry with 10.7MHz marker centered on the response.
2	IF trans.	*FM antenna terminal or TEST POINT (A)	10.7MHz (Unmod.)	Any non-interfering setting	SCOPE to the TEST POINT (C)	(X05-0010-13) Ta6 Prim. & Sec.	Maximum amplitude and symmetry with 10.7MHz marker centered on the response.
Check the MUTING SW to the OFF and emitter voltage of transistor Qa6 to be more 1.9V. If voltage does not appear disconnect the wire of "C" terminal in X05-0010-13. And then connect the resistor 560Ω to the capacitor Ca38 in parallel.							
3	IF trans.	*FM antenna terminal or TEST POINT (A)	10.7MHz (Unmod.)	Any non-interfering setting	SCOPE to the TEST POINT (D)	(X05-0010-13) Ta7 Prim. & Sec.	Maximum amplitude and symmetry with 10.7MHz marker centered on the response
4	DISCRIMINATOR	*FM antenna terminal or TEST POINT (A)	98MHz 400Hz (Mod.) 75kHz (Dev.) 0.5~1mV	Tune for maximum using tuning indicator	SCOPE to the recording jack	(X05-0010-13) Ta8 Prim. & Sec.	S-response and its symmetry on each side of 10.7MHz center frequency.
5	RF	FM antenna terminal	90MHz 400Hz (Mod.) 75kHz (Dev.) 1.5~2μV	90MHz	VTVM to the recording jack	(X05-0010-13) Ta4	Turn it to receive the SSG freq.
6	RF	FM antenna terminal	90MHz 400Hz (Mod.) 75kHz (Dev.) 1.5~2μV	90MHz	VTVM to the recording jack	(X05-0010-13) Ta1, 2	Adjust the sensitivity to be maximum.
7	RF	FM antenna terminal	106MHz 400Hz (Mod.) 75kHz (Dev.) 1.5~2μV	106MHz	VTVM to the recording jack	(X05-0010-13) CTa3	Turn it to receive the SSG freq.
8	RF	FM antenna terminal	106MHz 400Hz (Mod.) 75kHz (Dev.) 1.5~2μV	106MHz	VTVM to the recording jack	(X05-0010-13) CTa1, 2	Adjust sensitivity to the maximum
9	Repeat steps 5 ~ 8 until no further improvement is possible.						
10	METER	FM antenna terminal	98MHz 400Hz (Mod.) 75kHz (Dev.) 1mV	Tune for maximum using tuning indicator	-	(X05-0010-13) VRa1	"4" indicates
11	OUT	FM antenna terminal	98MHz 400Hz (Mod.) 75kHz (Dev.) 1mV	Tune for maximum using tuning indicator	VTVM to the recording jack	(X05-0010-13) VRa2	Adjust the output to be 1V
* If can't see the waveform on the scope, move the sweep generator to the TEST POINT (A). A across the antenna terminal in series with a capacitor 5 ~ 10pF.							

● ADJUSTMENT

■ SCA FILTER ADJUSTMENT

STEP	AUDIO SIGNAL GENERATOR COUPLING	AUDIO SIGNAL GENERATOR FREQ.	AC VTVM & SCOPE COUPLING	ADJUST	CHECK
1	TEST POINT (E)	67kHz 1V	TEST POINT (F)	(X05-0010-13) Ta15	Minimum deflection

■ MPX ADJUSTMENT

STEP	COUPLING	FM SSG MOD. FREQ.	SELECTOR	19kHz PILOT	VTVM & SCOPE COUPLING	ADJUST	CHECK
1	FM antenna terminal	98MHz 400Hz (Mod.) 67.5kHz (Dev.) 1mV	NORMAL or REVERSE	ON	OFF	(X05-0010-13) VRa4, VRa5	"STEREO" indicator illuminate
2	FM antenna terminal	98MHz 400Hz (Mod.) 67.5kHz (Dev.) 1mV	REVERSE	ON	Recording jack	(X05-0010-13) Ta13, Ta14	With Ta13 increase the output to be max. and with Ta14 make the best waveform.
3	FM antenna terminal	98MHz 400Hz (Mod.) 40kHz (Dev.)	NORMAL	ON	Recording jack	(X05-0010-13) VRa5	Adjust the variable resistor until the indicator goes out and bring them back to the point where they are turned on again.
4	FM antenna terminal	98MHz 400Hz (Mod.) 67.5kHz (Dev.) 10μV	NORMAL	ON	Recording jack	(X05-0010-13) VRa4	
5	FM antenna terminal	98MHz 400Hz (Mod.) 67.5kHz (Dev.) 1mV	LEFT	ON	Recording jack of RIGHT	(X09-1020-00) VRe3	Minimum RIGHT output.
6	FM antenna terminal	98MHz 400Hz (Mod.) 67.5kHz (Dev.) 1mV	RIGHT	ON	Recording jack of LEFT	(X09-1020-00) VRe3	Minimum LEFT output.

* As can't get the same value, set the variable resistor to the point taking the average.

■ MUTING ADJUSTMENT

Coupling the SSG to the antenna terminal, setting MUTING SW to be OFF, and VTVM to recording jack. As supply the signal (98MHz, modulation at 400Hz, deviation of 75kHz, input 1mV) to the set VTVM indicates 1V. Next set the MUTING SW to ON and adjust the variable resistor VR4 (50kΩ) so that VTVM indicates 0.5 ~ 0.7V.

More check whether AM broadcast is received or not. If not, check whether base voltage of transistor Q1 is supplied more 0.6V or not.

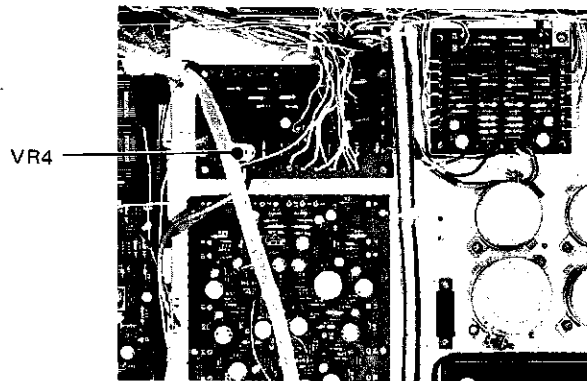

TOP CHASSIS VIEW

● ADJUSTMENT

■ AM ADJUSTMENT

STEP	ALIG	SSG		TUNING DIAL SETTING	VTVM & OSC COUPLING	ADJUST	CHECK
		COUPLING	SIGNAL				
1	IF Trans.	AM antenna terminal	455kHz	Any non-interfering	Recording jack	X05-0010-13 Ta10	Maximum amplitude and symmetry with 455kHz marker centered on response
2	IF Trans.	AM antenna terminal	455kHz	Any non-interfering	Recording jack	X05-0010-13 Ta11	Maximum amplitude and symmetry with 455kHz marker centered on response
3	IF Trans.	AM antenna terminal	455kHz	Any non-interfering	Recording jack	X05-0010-13 Ta12	Maximum amplitude and symmetry with 455kHz marker centered on response
4	RF	AM antenna terminal	600kHz 400Hz (30% Mod.) 1mV	600kHz	Recording jack	X05-0010-13 Ta9, Loopstick antenna	With Ta9 correspond to SSG freq. With Loopstick antenna the sensitivity to be maximum.
5	RF	AM antenna terminal	1,400kHz 400Hz (30% Mod.)	1,400kHz	Recording jack	X05-0010-13 CTa4	With CTa4 correspond to SSG freq.
* Repeat steps 4, 5 until no further improvement is possible.							
6	METER	AM antenna terminal	1000kHz 400Hz (30% Mod.)	1000kHz	Recording jack	X05-0010-13 VRa3	"4" indicates

■ DIAL CORD STRINGING

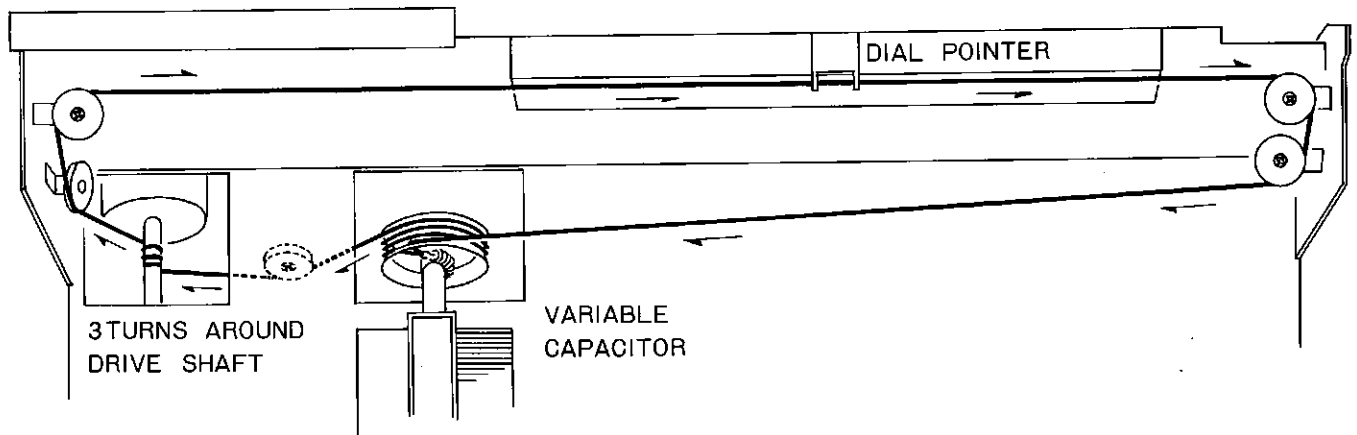

ADJUSTMENT

TESTING PROCEDURES

Perform the test according to the following procedures.

1. Using a tester, measure the voltage between the chassis and collector of the power transistor Q2 or Q5. If a tester indicates approximately 68V, it is normal.
2. Also measure the voltage between the chassis and collector of the power transistor Q3 or Q4. If a tester indicates approximately 34V, it is normal.

IDLING CURRENT

1. Connect the dummy load (8Ω , 80 watts) to the output terminal.
2. Connect the audio generator to the main unit. Oscilloscope and AC VTVM are connected across the dummy.
3. Before checking the idling current, turn on power switch in a few minutes, adjust the variable resistor (VRe1, 2) so that tester (or DC VTVM) coupling to the collector of transistors indicates 30mA. And also check the waveform to be correct feeding the signal (1kHz) to the set.

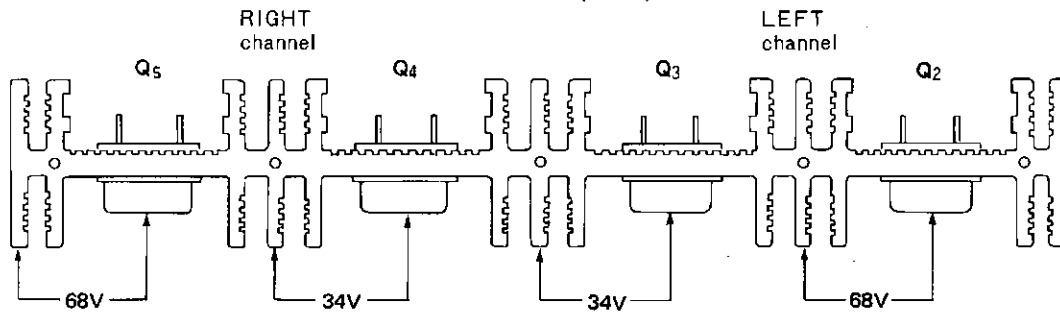

ON METER SETTING

As supply the signal (1kHz, 100mV) to the MAIN-IN jack, setting POWER LIMITER at FULL, PRE-MAIN SEPARATE SW at SEPARATE, right meter indicates around the 0VU. And then adjust the PC trimmer potentiometer VR5 ($3k\Omega$) so that left meter indicates the 0VU as well as right.

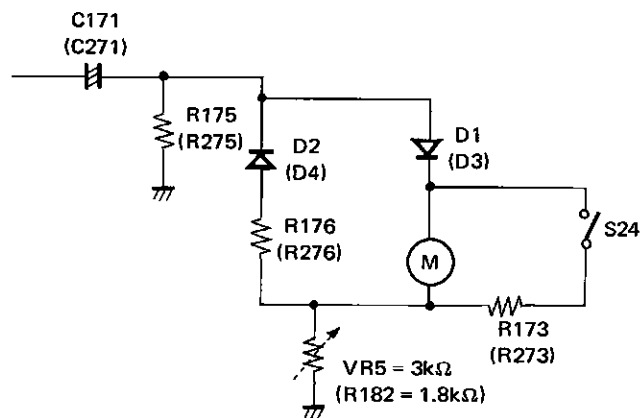

ON MIC JACK

As plug the MIC jack in MIC-L speakers work as monophonic. And then the MIC jack in MIC-R only right speaker does. Next plug MIC jacks in MIC-R and MIC-L each speakers work as stereophonic.

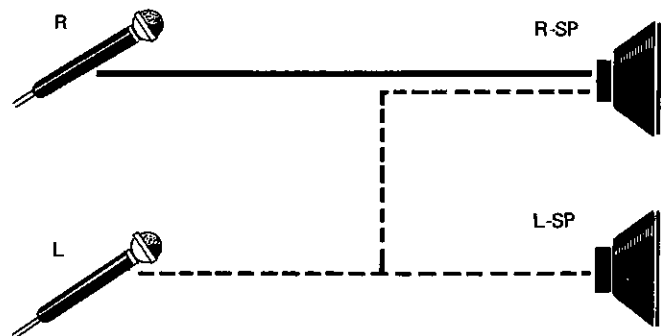

● ADJUSTMENT

■ ON GUITAR JACK

As plug the GUITAR jack in GUITAR-R speakers work as monophonic. And then the GUITAR jack in GUITAR-L only left speaker does. Next plug GUITAR-jacks in GUITAR-R and GUITAR-L each speakers work as stereophonic.

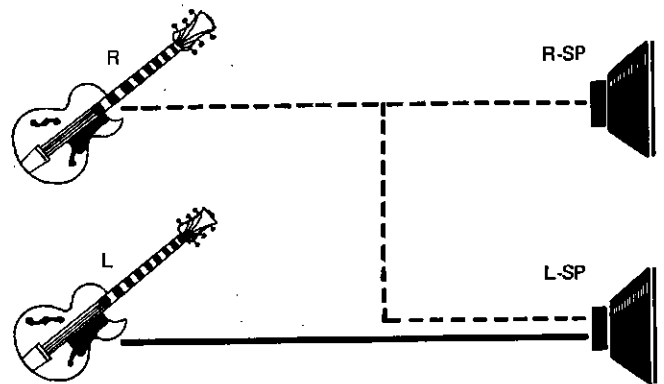

■ ON TIMER

The time lag is often caused by the bend and aberration of TIMER shaft. Check whether the shaft is the proper connection or not.

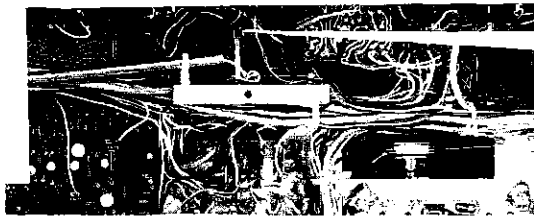

■ RELATION OF SPEAKERS SELECTOR AND SPEAKERS

See the right table. It is the table that the relation of speaker connection and speaker selector. For example, push the selector button B or A & B, connecting the speakers to A terminal, they don't work. And also push the button A or A & B, connecting the speakers to B terminal, they don't.

Selector \ SP	A (C)	B (D)	A & B (C & D)
A (C)			
B (D)			
A & B (C & D)			

speakers to work

speakers not to work

■ HOW TO REPLACE THE PC BOARD

Pc boards are stopped by screws. As replace them loose screws.

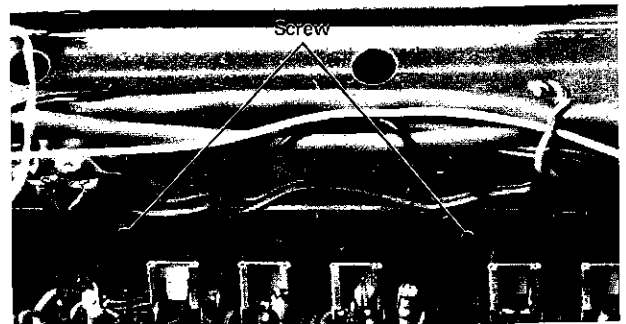

● SPECIFICATIONS

FM TUNER SECTION:

ANTENNA IMPEDANCE: 300 ohms balanced & 75 ohms unbalanced.
USABLE SENSITIVITY (IHF): 1.9 μ V
HARMONIC DISTORTION MONO: 0.5%
(at 400Hz 100% Mod.) STEREO: 0.8%
SIGNAL TO NOISE RATIO: 60 dB
CAPTURE RATIO (IHF): 4.0 dB
SELECTIVITY (ALT. CH.) (IHF): 45 dB
IMAGE REJECTION: 60 dB
IF REJECTION: 100 dB
AM SUPPRESSION: 45 dB
STEREO SEPARATION (at 1 kHz): 30 dB
(at 10 kHz): 20 dB
SUB CARRIER SUPPRESSION: 40 dB
STEREO AUTO-SWITCHING LEVEL: 10 μ V
FRONT END: 1-FET, 3-Gang
IF-STAGE: 1-IC

AM TUNER SECTION:

ANTENNA: Built-in ferrite bar antenna & External antenna terminals
USABLE SENSITIVITY (IHF): 25 μ V
SELECTIVITY (IHF): 25 dB
IMAGE REJECTION: 45 dB
IF REJECTION: 35 dB
FRONT END: 2-Gang

AMPLIFIER SECTION:

POWER OUTPUT:
both ch. at 4 ohms: 180 watts
both ch. at 8 ohms: 130 watts
DYNAMIC POWER OUTPUT:
both ch. at 4 ohms: 150 watts
both ch. at 8 ohms: 110 watts
CONTINUOUS POWER OUTPUT:
each ch. at 4 ohms: 50/50 watts
each ch. at 8 ohms: 40/40 watts
both ch. at 4 ohms: 39/39 watts
both ch. at 8 ohms: 33/33 watts
HARMONIC DISTORTION (at rated): 0.5%
(at -3 dB rated): 0.1%
INTERMODULATION DISTORTION:
(at rated): 0.5%
(at -3 dB rated): 0.2%
FREQUENCY RESPONSE:
HIGH LEVEL (AUX) INPUT: 20 ~ 40,000 Hz \pm 1.5 dB
POWER BANDWIDTH (IHF): 17 ~ 30,000 Hz
HUM & NOISE:
PHONO 1, 2: 65 dB
MIC: 58 dB
AUX/TAPE PLAY: 75 dB
INPUT SENSITIVITY (for rated output):
PHONO 1: 2.5 mV 50 K ohms
PHONO 2: 2.5 mV 50 K ohms
MIC: 2.0 mV 10 K ohms
GUITAR: 20 mV 30 K ohms
AUX 1: 180 mV 50 K ohms
AUX 2: 180 mV 50 K ohms
TAPE PLAY A: 180 mV 50 K ohms
TAPE PLAY B: 180 mV 50 K ohms
MAIN INPUT: 100 mV

DAMPING FACTOR (at 8 ohms): 50
SPEAKER IMPEDANCE: accept 4 to 16 ohms
MULTI PRESENCE CONTROL
SELECTOR:

DEFEAT, LOUDNESS at 100 Hz: +10 dB
TONE, JAZZ, VOCAL, MOOD
BASS CONTROL (at 100 Hz): \pm 10 dB
TREBLE CONTROL (at 10,000 Hz): \pm 10 dB

ELECTRONIC RHYTHM COMPOSER SECTION:

RHYTHM SELECTOR:
(1) March, (2) Fox Trot, (3) Rock, (4) R & B, (5) Ballad,
(6) Shuffle, (7) Bossanova 1, (8) Bossanova 2, (9) Latin
Beat (10) Mambo, (11) Waltz, (12) Jazz Waltz.
ELECTRONIC PERCUSSIONS: 5 different Sounds
RHYTHM MODE SWITCH: Left, Right, Stereo, Reverse, Mono
FOOT SWITCH JACK: Yes.
ACCESSORY PARTS: Foot Switch (Remote Control Switch of
START and BREAK for E, R, C.)

REVERBERATION SECTION:

LEVEL CONTROL: 0 to 2 seconds
MODE: OFF—SOURCE—GUITAR—MIC—RHYTHM

TIMER SECTION:

2 hours

GENERAL:

SWITCHES: SPEAKERS: A, B, C, D.
SELECTOR: AM, FM AUTO, PHONO 1, PHONO
2, AUX 1, AUX 2, RHYTHM.
POWER LIMITER: 50 watts, 100 watts, Full
Power.
MODE SWITCHES: STEREO-MONO, NORMAL-
REVERSE
TAPE MONITOR A: SOURCE, PLAY
TAPE MONITOR B: SOURCE, PLAY
AUDIO MUTING: ON (-20 dB), OFF
FM MUTING: ON, OFF
LOW FILTER: ON, OFF
HIGH FILTER: ON, OFF
POWER METER: LOW, HIGH
PRE OUT: NORMAL, REVERB (Front)
PRE OUT-MAIN IN: NORMAL, SEPARATE
(Rear)
(for Separate Use of Pre and Main Amplifier)
OTHERS: B PHONES LEVEL
MIC LEVEL
GUITAR JACK (L, R)
MIC JACK (L, R)
PHONES JACK (A, B)
OUTPUT TERMINALS (Front)
PRE OUT - MAIN IN TERMINALS (Rear)
AC OUTLETS: SWITCHED 1
UNSWITCHED 2
POWER CONSUMPTION:
at full power: 240 watts
at no signal: 45 watts
DIMENSIONS: W 21-3/4" x H 6-3/4" x D 16-1/4"
WEIGHT: 29 lbs (16 kg)
ACCESSORY PARTS: Dynamic MIC
WALNUT CABINET: Yes

RHYTHM SCHEMATIC DIAGRAM

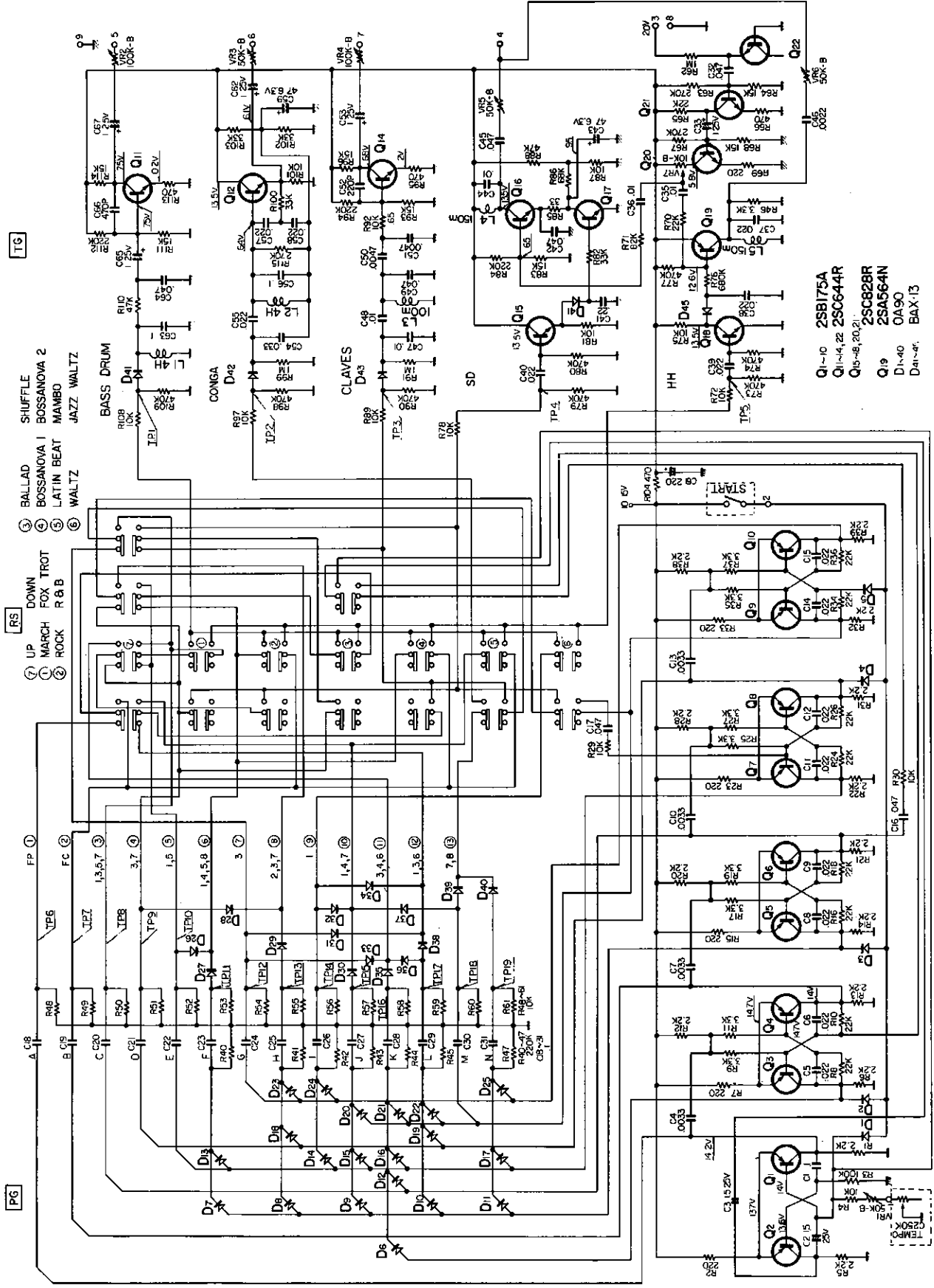

- RS**
- ① UP
 - ② DOWN
 - ③ MARCH
 - ④ FOX TROT
 - ⑤ ROCK
 - ⑥ R & B
- TG**
- ③ BALLAD
 - ④ BOSSANOVA 1
 - ⑤ LATIN BEAT
 - ⑥ WALTZ
 - SHUFFLE
 - BOSSANOVA 2
 - MANBO
 - JAZZ

- Q1-10 2SB175A
- Q11-14, 22 2SC644R
- Q15-18, 20, 21 2SC82BR
- Q19 2SA564N
- D1-40 OA90
- D41-42 BAX-13

SCHEMATIC DIAGRAM

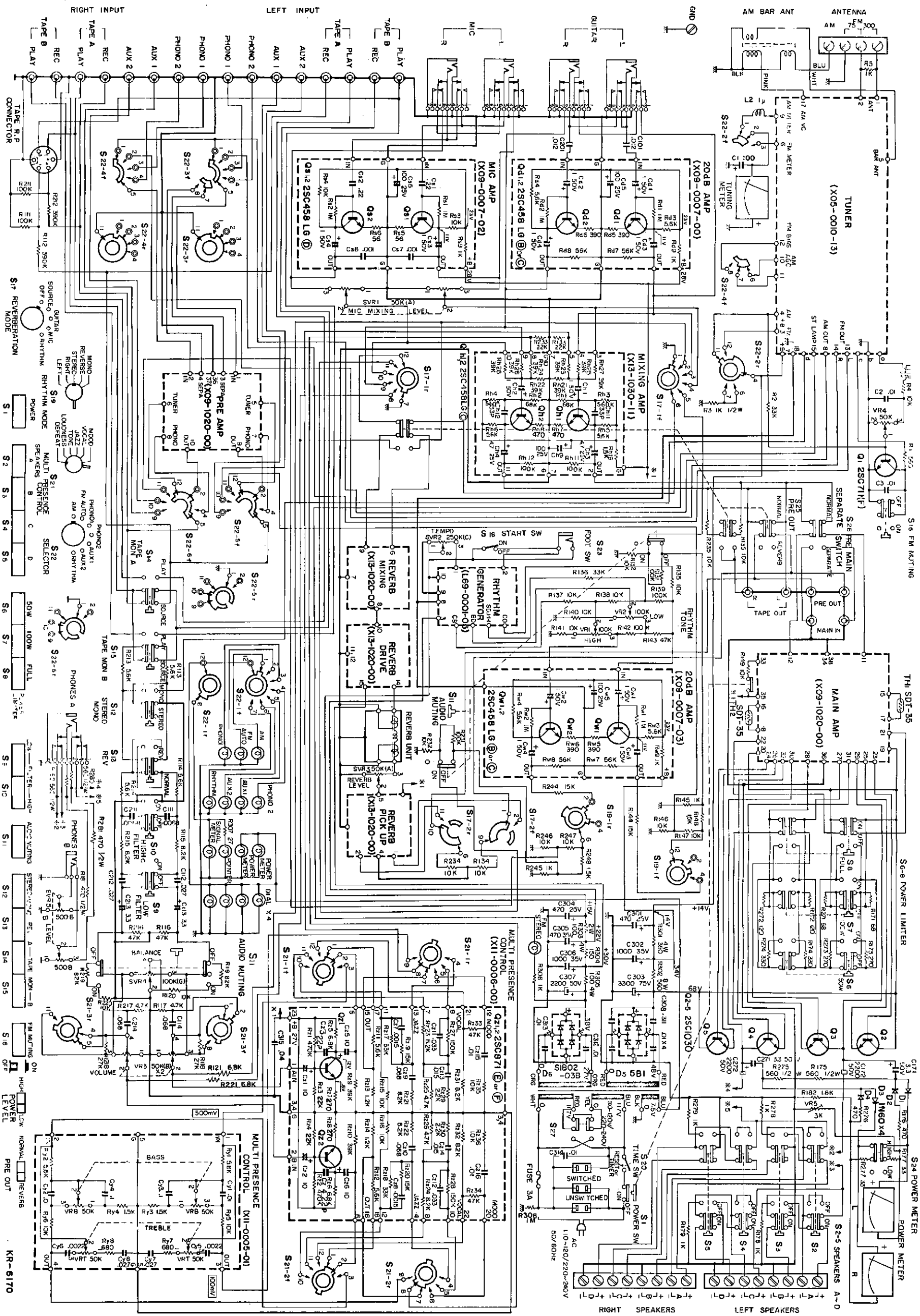

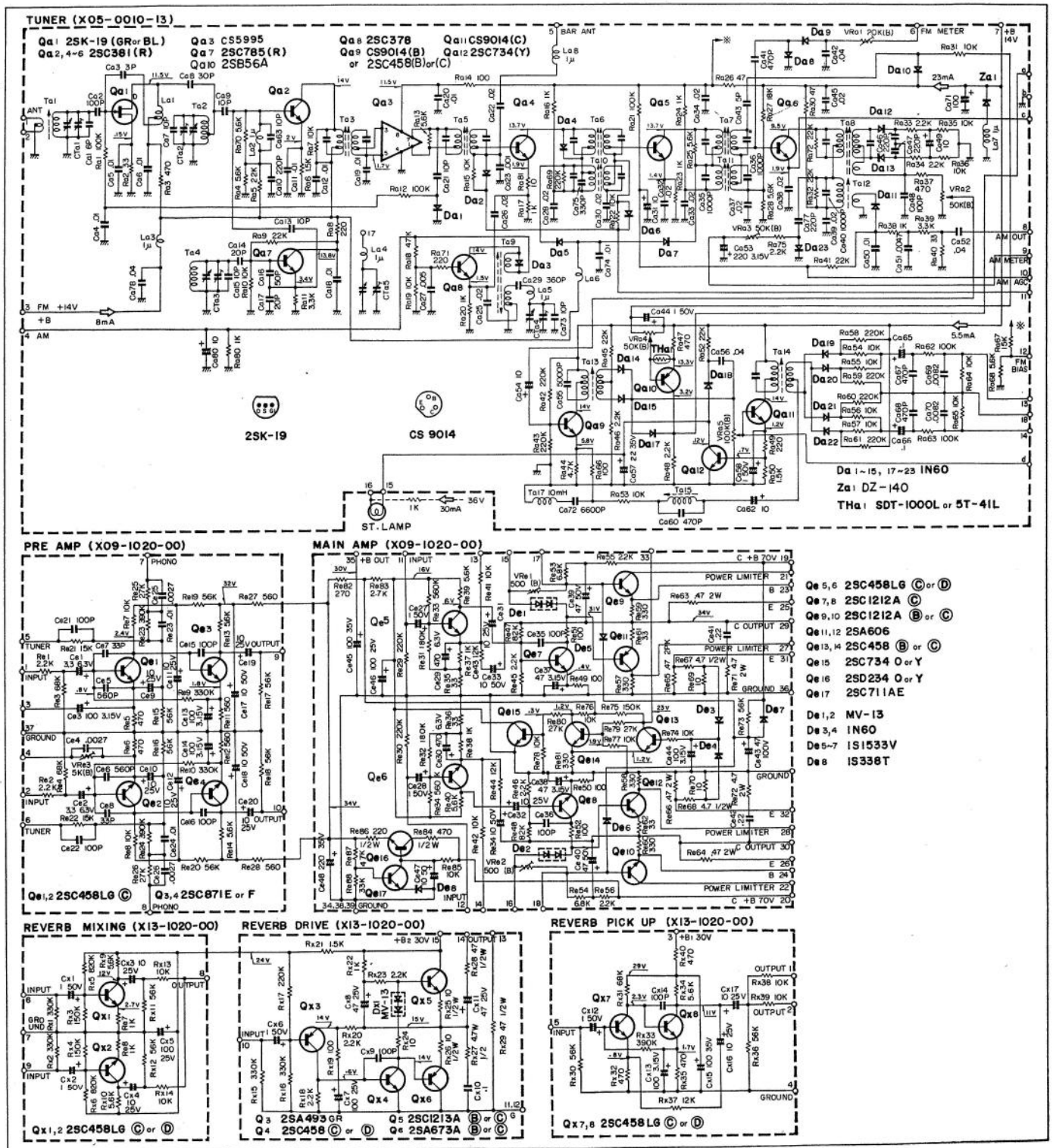

● PARTS LIST

Circuit No.	Parts No.	Description	Remarks
UNIT			
—	X05-0010-13	TUNER unit	
—	X09-0007-00	GUITAR AMP unit	
—	X09-0007-02	MIC AMP unit	
—	X09-0007-03	RHYTHM AMP unit	
—	X09-1020-00	PRE & MAIN unit	
—	X11-0005-01	MULTI PRESENCE unit	
—	X11-0006-00	MULTI PRESENCE unit	
—	X13-1020-00	REVERB AMP unit	
—	X13-1030-11	MIXING AMP unit	
—	L69-0001-05	RHYTHM GENERATOR unit	
CAPACITOR			
C1	CE04W0F101	PC electrolytic	100 μ F 3.15WV
C2, 3	CK94YY1H103M	Ceramic	0.01 μ F \pm 20%
C101	CQ92M1H123M	Mylar	0.012 μ F \pm 20%
C111	CQ92M1H682M	Mylar	0.0068 μ F \pm 20%
C112	CQ92M1H273M	Mylar	0.027 μ F \pm 20%
C113	CE04W1H3R3	PC electrolytic	3.3 μ F 50WV
C114	CQ92M1H683M	Mylar	0.068 μ F \pm 20%
C171	CE04W1H3R3	PC electrolytic	3.3 μ F 50WV
C172	CE62AW1H222	Electrolytic block	2200 μ F 50WV
C201	CQ92M1H123M	Mylar	0.012 μ F \pm 20%
C211	CQ92M1H682M	Mylar	0.0068 μ F \pm 20%
C212	CQ92M1H273M	Mylar	0.027 μ F \pm 20%
C213	CE04W1H3R3	PC electrolytic	3.3 μ F 50WV
C214	CQ92M1H683M	Mylar	0.068 μ F \pm 20%
C271	CE04W1H3R3	PC electrolytic	3.3 μ F 50WV
C272	CE62AW1H222	Electrolytic block	2200 μ F 50WV
C301	CE02W1E471	Electrolytic tubular	470 μ F 25WV
C302	CE02W1V102	Electrolytic tubular	1000 μ F 35WV
C303	CE62AW1K332	Electrolytic block	3300 μ F 75WV
C304	CE02W1E471	Electrolytic tubular	470 μ F 25WV
C305	CE02W1V471	Electrolytic tubular	470 μ F 35WV
C306	CE02W1V102	Electrolytic tubular	1000 μ F 35WV
C307	CE62AW1H222	Electrolytic block	2200 μ F 50WV
C308~313	CP02B2J103M	Oil filled	0.01 μ F \pm 20%
C314	C90-0036-05	Oil filled (UL, CSA)	0.01 μ F \pm 20%
C315	CK94YX1H403M	Ceramic	0.04 μ F \pm 20%
RESISTOR			
R1	PD14BY2E561J	Insulated carbon film	560 Ω \pm 5% 1/4W
R2	PD14BY2E333J	Insulated carbon film	33k Ω \pm 5% 1/4W
R3	RC05GF2H102K	Carbon composition	1k Ω \pm 10% 1/2W
R4	PD14BY2E103J	Insulated carbon film	10k Ω \pm 5% 1/4W
R5	PD14BY2E102J	Insulated carbon film	1k Ω \pm 5% 1/4W
R111	PD14BY2E104J	Insulated carbon film	100k Ω \pm 5% 1/4W
R112	PD14BY2E394J	Insulated carbon film	390k Ω \pm 5% 1/4W
R113, 114	PD14BY2E562J	Insulated carbon film	5.6k Ω \pm 5% 1/4W
R115	PD14BY2E822J	Insulated carbon film	8.2k Ω \pm 5% 1/4W
R116	PD14BY2E473J	Insulated carbon film	47k Ω \pm 5% 1/4W
R117	PD14BY2E472J	Insulated carbon film	4.7k Ω \pm 5% 1/4W
R118	PD14BY2E273J	Insulated carbon film	27k Ω \pm 5% 1/4W
R119	PD14BY2E823J	Insulated carbon film	82k Ω \pm 5% 1/4W
R120	PD14BY2E103J	Insulated carbon film	10k Ω \pm 5% 1/4W
R121	PD14BY2E682J	Insulated carbon film	6.8k Ω \pm 5% 1/4W
R131	PD14BY2E104J	Insulated carbon film	100k Ω \pm 5% 1/4W

● PARTS LIST

Circuit No.	Parts No.	Description	Remarks
R132	PD14BY2E103J	Insulated carbon film 10k Ω \pm 5% 1/4W	
R133	PD14BY2E223J	Insulated carbon film 22k Ω \pm 5% 1/4W	
R134, 135	PD14BY2E103J	Insulated carbon film 10k Ω \pm 5% 1/4W	
R136	PD14BY2E333J	Insulated carbon film 33k Ω \pm 5% 1/4W	
R137, 138	PD14BY2E103J	Insulated carbon film 10k Ω \pm 5% 1/4W	
R139	PD14BY2E104J	Insulated carbon film 100k Ω \pm 5% 1/4W	
R140, 141	PD14BY2E103J	Insulated carbon film 10k Ω \pm 5% 1/4W	
R142	PD14BY2E104J	Insulated carbon film 100k Ω \pm 5% 1/4W	
R143	PD14BY2E473J	Insulated carbon film 47k Ω \pm 5% 1/4W	
R144	PD14BY2E153J	Insulated carbon film 15k Ω \pm 5% 1/4W	
R145	PD14BY2E102J	Insulated carbon film 1k Ω \pm 5% 1/4W	
R146, 147	PD14BY2E103J	Insulated carbon film 10k Ω \pm 5% 1/4W	
R148	PD14BY2E152J	Insulated carbon film 1.5k Ω \pm 5% 1/4W	
R149	PD14BY2E103J	Insulated carbon film 10k Ω \pm 5% 1/4W	
R171	PD14BY2E680J	Insulated carbon film 68 Ω \pm 5% 1/4W	
R172	PD14BY2E121J	Insulated carbon film 120 Ω \pm 5% 1/4W	
R173	PD14BY2E271J	Insulated carbon film 270 Ω \pm 5% 1/4W	
R174	PD14BY2E331J	Insulated carbon film 330 Ω \pm 5% 1/4W	
R175	RC05GF2H561J	Carbon composition 560 Ω \pm 5% 1/4W	
R176	PD14BY2E471J	Insulated carbon film 470 Ω \pm 5% 1/4W	
R177	PD14BY2E330J	Insulated carbon film 33 Ω \pm 5% 1/4W	
R178, 179	RC05GF2H102K	Carbon composition 1k Ω \pm 10% 1/2W	
R180	RC05GF2H561J	Carbon composition 560 Ω \pm 5% 1/2W	
R181	RC05GF2H471J	Carbon composition 470 Ω \pm 5% 1/2W	
R182	PD14BY2E182J	Insulated carbon film 1.8k Ω \pm 5% 1/4W	
R211	PD14BY2E104J	Insulated carbon film 100k Ω \pm 5% 1/4W	
R212	PD14BY2E394J	Insulated carbon film 390k Ω \pm 5% 1/4W	
R213, 214	PD14BY2E562J	Insulated carbon film 5.6k Ω \pm 5% 1/4W	
R215	PD14BY2E822J	Insulated carbon film 8.2k Ω \pm 5% 1/4W	
R216	PD14BY2E473J	Insulated carbon film 47k Ω \pm 5% 1/4W	
R217	PD14BY2E472J	Insulated carbon film 4.7k Ω \pm 5% 1/4W	
R218	PD14BY2E273J	Insulated carbon film 27k Ω \pm 5% 1/4W	
R219	PD14BY2E823J	Insulated carbon film 82k Ω \pm 5% 1/4W	
R220	PD14BY2E103J	Insulated carbon film 10k Ω \pm 5% 1/4W	
R221	PD14BY2E682J	Insulated carbon film 6.8k Ω \pm 5% 1/4W	
R231	PD14BY2E104J	Insulated carbon film 100k Ω \pm 5% 1/4W	
R232	PD14BY2E103J	Insulated carbon film 10k Ω \pm 5% 1/4W	
R233	PD14BY2E223J	Insulated carbon film 22k Ω \pm 5% 1/4W	
R234, 235	PD14BY2E103J	Insulated carbon film 10k Ω \pm 5% 1/4W	
R244	PD14BY2E153J	Insulated carbon film 15k Ω \pm 5% 1/4W	
R245	PD14BY2E102J	Insulated carbon film 1k Ω \pm 5% 1/4W	
R246, 247	PD14BY2E103J	Insulated carbon film 10k Ω \pm 5% 1/4W	
R248	PD14BY2E152J	Insulated carbon film 1.5k Ω \pm 5% 1/4W	
R271	PD14BY2E680J	Insulated carbon film 68 Ω \pm 5% 1/4W	
R272	PD14BY2E121J	Insulated carbon film 120 Ω \pm 5% 1/4W	
R273	PD14BY2E271J	Insulated carbon film 270 Ω \pm 5% 1/4W	
R274	PD14BY2E331J	Insulated carbon film 330 Ω \pm 5% 1/4W	
R275	RC05GF2H561J	Carbon composition 560 Ω \pm 5% 1/2W	
R276	PD14BY2E471J	Insulated carbon film 470 Ω \pm 5% 1/4W	
R277	PD14BY2E331J	Insulated carbon film 330 Ω \pm 5% 1/4W	
R278, 279	RC05GF2H102K	Carbon composition 1k Ω \pm 10% 1/2W	
R280	RC05GF2H561J	Carbon composition 560 Ω \pm 5% 1/2W	
R281	RC05GF2H471J	Carbon composition 470 Ω \pm 5% 1/2W	
R301	RW14AG3G391J	Wire wound 390 Ω \pm 5% 4W	
R302	RW14AG3K561J	Wire wound 560 Ω \pm 5% 8W	
R303	RW14AG3D101J	Wire wound 100 Ω \pm 5% 2W	

● PARTS LIST

Circuit No.	Parts No.	Description	Remarks
R304	RW14AG3G151J	Wire wound 150Ω ±5% 4W	
R305	RW14AG3G101J	Wire wound 100Ω ±5% 4W	
R306	RW14AG3D101J	Wire wound 100Ω ±5% 2W	
R307	RC05GF2H270K	Carbon composition 27Ω ±5% 1/2W	
R308	RC05GF2H105K	Carbon composition 1MΩ ±10% 1/2W	
POTENTIOMETER			
VR1	R01-5006-05	HIGH RHYTHM TONE 100kΩ (B)	
VR2	R01-5006-05	LOW RHYTHM TONE 100kΩ (B)	
VR3	R01-4004-05	VOLUME 50kΩ (B) dual	
VR4	R12-4015-05	PC trimmer potentiometer 50kΩ	
VR5	R12-1016-05	PC trimmer potentiometer 3kΩ	
SVR1	R13-4008-05	MIXING LEVEL 50kΩ (A) slide 2-gang	
SVR2	R13-6002-05	TEMPO 250kΩ (C) slide	
SVR3	R13-4007-05	REVERB LEVEL 50kΩ (A) slide	
SVR4	R13-5001-05	BALANCE 100kΩ (G) slide	
SVR5	R13-0001-05	PHONES LEVEL 500Ω (B) slide 2-gang	
SWITCH			
S1	S41-8001-05	POWER (eight-pushbutton A)	
S2	S41-8001-05	SPEAKERS A (eight-pushbutton A)	
S3	S41-8001-05	SPEAKERS B (eight-pushbutton A)	
S4	S41-8001-05	SPEAKERS C (eight-pushbutton A)	
S5	S41-8001-05	SPEAKERS D (eight-pushbutton A)	
S6	S41-8001-05	50W POWER LIMITER (eight-pushbutton A)	
S7	S41-8001-05	100W POWER LIMITER (eight-pushbutton A)	
S8	S41-8001-05	FULL POWER (eight-pushbutton A)	
S9	S41-8002-05	LOW FILTER (eight-pushbutton B)	
S10	S41-8002-05	HIGH FILTER (eight-pushbutton B)	
S11	S41-8002-05	AUDIO MUTING (eight-pushbutton B)	
S12	S41-8002-05	STEREO/MONO (eight-pushbutton B)	
S13	S41-8002-05	REV. (eight-pushbutton B)	
S14	S41-8002-05	TAPE MONITOR A (eight-pushbutton B)	
S15	S41-8002-05	TAPE MONITOR B (eight-pushbutton B)	
S16	S41-8002-05	FM MUTING (eight-pushbutton B)	
S17	S01-2008-05	REVERB MODE (rotary) F · 2 · 6 · 5	
S18	S40-1001-05	RHYTHM SELECTOR	
S19	S01-1009-05	RHYTHM MODE (rotary) F · 1 · 2 · 5	
S20	S59-1025-05	TIMER	
S21	S01-3006-05	MULTI PRESENCE TONE (rotary) F · 3 · 6 · 6	
S22	S01-6001-05	SELECTOR (rotary) F · 6 · 15 · 7	
S23	Y15-1000-80	FOOT SW	
S24	S31-6005-05	VU LEVEL (slide)	
S25	S31-6005-05	PRE OUT (slide)	
S26	S31-2007-05	PRE/MAIN SEPARATE SW (slide)	
S27	S31-2004-05	VOLTAGE SELECTOR (slide)	
S28	S36-1001-05	START SW (lever)	
TRANSISTOR/DIODE/THERMISTOR			
Q1		2SC711(F)	
Q2~5		2SC1030	
D1~4		1N60	
D5		5B1	
D6		S1B02-03B	
TH1, 2		SDT-35	
MISCELLANEOUS			
—	A03-0078-22	Cabinet	

● PARTS LIST

Circuit No.	Parts No.	Description	Remarks
—	A10-0260-11	Chassis	
—	A20-0408-21	Panel	
—	A21-0066-22	Ornamental plate	
—	A22-0100-11	Sub panel	
—	A23-0221-01	Rear panel	
—	A33-0014-03	Reflector	
—	A42-0007-12	Bottom plate	
—	A70-0055-23	Panel assembly	
—	B01-0049-04	Left side escutcheon	
—	B01-0050-04	Right side escutcheon	
—	B04-0033-04	Screen	
—	B04-0035-04	Screen	
—	B08-2010-04	Indicator (blue)	
—	B10-0058-02	Front glass	
—	B19-0104-03	Filter	
—	B20-0201-03	Dial calibrations	
—	B21-4006-05	Dial pointer assembly	
P.L	B30-0015-15	Fuse type pilot lamp	
P.L	B30-0026-15	STEREO indicator (30mA, 8V)	
P.L	B30-0039-05	Pilot lamp (50mA, 8V)	
M	B31-0006-05	Signal meter	
M	B31-0119-05	VU meter	
—	B40-0504-04	Destination plate (P)	
—	B41-0105-04	Power voltage plate (P)	
—	B41-0110-04	Voltage selector caution card (P)	
—	B42-0009-04	Passed sticker	
—	B42-0046-14	UL caution card (K)	
—	B42-0161-04	Loopstick antenna caution sticker	
—	B42-0219-04	UL caution card (K)	
—	B42-0267-04	UL caution card (K, U)	
—	B46-0002-00	Warranty card (K, U)	
—	B46-0003-00	Warranty card (U)	
—	B46-0021-00	Warranty card (P)	
—	B47-0029-04	TIMER caution card	
—	B47-0032-04	REVERB CRAMP caution card	
—	B50-0667-00	Instruction manual (K, P)	
—	B50-0668-00	Instruction manual (U)	
—	B52-0101-00	Schematic diagram	
—	B58-0003-00	Power supply caution card (U)	
—	B58-0043-00	Carton case caution card (K, P)	
—	B58-0101-00	Voltage selector caution card (U)	
—	B58-0114-04	Voltage selector caution card (P)	
—	B58-0125-00	Caution card	
—	B59-0018-00	KENWOOD service stations lists (U)	
—	D01-0009-05	Flywheel	
—	D15-0037-04	Small pulley	
—	D15-0038-04	Pulley	
—	D15-0073-04	Pulley x 4	
—	D20-0087-03	Dial shaft	
—	D21-0182-03	Shaft	
—	D22-0018-05	Shaft coupling	
—	D23-0060-04	Shaft bearing	
—	D32-0021-04	Switch stopper	
—	E02-0207-05	Transistor socket	

● PARTS LIST

Circuit No.	Parts No.	Description	Remarks
—	E05-0203-05	Power plug (W)	
—	E08-0205-05	AC outlet	
J	E08-0217-05	Foot switch jack	
J	E11-0002-05	Phone jack (A)	
J	E11-0044-05	Phone jack	
J	E11-0048-05	Phone jack x 4	
J	E13-0205-05	2P pin jack	
J	E13-0401-05	4P pin jack (TAPE A)	
J	E13-0404-05	4P pin jack	
J	E13-0408-05	4P pin jack (TAPE B)	
J	E13-0802-05	8P pin jack	
—	E20-0418-03	4P terminal strips	
—	E20-0807-03	8P terminal strips	
—	E30-0046-05	Power cord (K, U, P)	
—	F01-0069-03	Head sink	
F	F05-3022-05 or F05-3024-05	Fuse (3A)	
—	F10-0205-04	Shield plate	
—	F10-0232-04	Shield plate	
—	F11-0141-04	Reflector box	
—	F30-0020-04	Bottom plate armature	
—	F31-0059-04	Armature	
—	F31-0060-04	Chassis armature	
—	F31-0061-04	Chassis armature	
—	G01-0045-14	Dial spring	
—	G01-0049-14	Dial spring x 5	
—	G13-0047-04	Reverb cushion	
—	G13-0050-04	Dial stopper	
—	G13-0051-04	Dial stopper	
—	H01-0648-04	Carton Case (K, U, P)	
—	H03-0047-04	Carton case (K, P)	
—	J02-0049-14	Legs	
—	J13-0016-15	Fuse holder	
—	J13-0023-05	Fuse holder x 7	
—	J19-0147-03	Meter stopper	
—	J19-0148-04	Dial stopper	
—	J19-0149-03	Push switch stopper	
—	J19-0150-04	Push switch stopper	
—	J19-0160-04	Dial stopper	
—	J20-0181-03	Switch stopper	
—	J21-0192-04	Amp. hardware	
—	J21-0480-13	Antenna stopper	
—	J21-0798-04	Pilot lamp hardware	
—	J21-0799-04	Pulley hardware	
—	J21-0800-03	Reverb hardware (A)	
—	J21-0801-03	Reverb hardware (B)	
—	J21-0801-04	Reverb hardware (C)	
—	J21-0546-04	Thermistor holder	
—	J21-0682-04	PC board hardware	
—	J25-0564-02	PC board (push switch with power)	
—	J25-0565-02	PC board (push switch)	

● PARTS LIST

Circuit No.	Parts No.	Description	Remarks
-	J25-0566-04	PC board (FM MUTING)	
-	J25-0574-04	PC board (FM MUTING)	
-	K23-0049-03	Knob (VOLUME, SELECTOR)	
-	K23-0050-03	Knob (REVERB MODE)	
-	K23-0051-14	Knob (BALANCE, TEMPO, REVERB LEVEL)	
-	K23-0061-04	Knob (RHYTHM TONE, BASS, TREBLE)	
-	K23-0068-03	Knob (TIMER)	
-	K23-0069-04	Knob (RHYTHM MODE, MULTIPRESENCE, CONTROL SELECTOR)	
-	K23-0070-03	Knob (TUNING)	
-	K29-0020-14	Knob (REVERB CRAMP, PHONES LEVEL, MIC LEVEL)	
-	K29-0073-04	Knob (START SW)	
P.T	L03-0047-05	Power transformer (47V-2.2A, 27V-0.4A, 7.5V-2.8A)	
L1, 2	L15-0009-05	Choke coil (4H) in RHYTHM GENERATOR	
L3	L15-0010-05	Choke coil (100mH) in RHYTHM GENERATOR	
L1, 2	L33-0086-05	Ferri-inductor (1 μ H)	
-	T29-0003-05	Reverbration unit	
ANT	T90-0002-05	FM indoor antenna	
ANT	T90-0026-05	Loopstick antenna	
MIC	T91-0016-05	Microphone	

* In America add to the parts of (K), in Canada do to that of (P), and in other area do to that of (U).

SEALED CIRCUIT ASSEMBLIES PHANTOM VIEWS

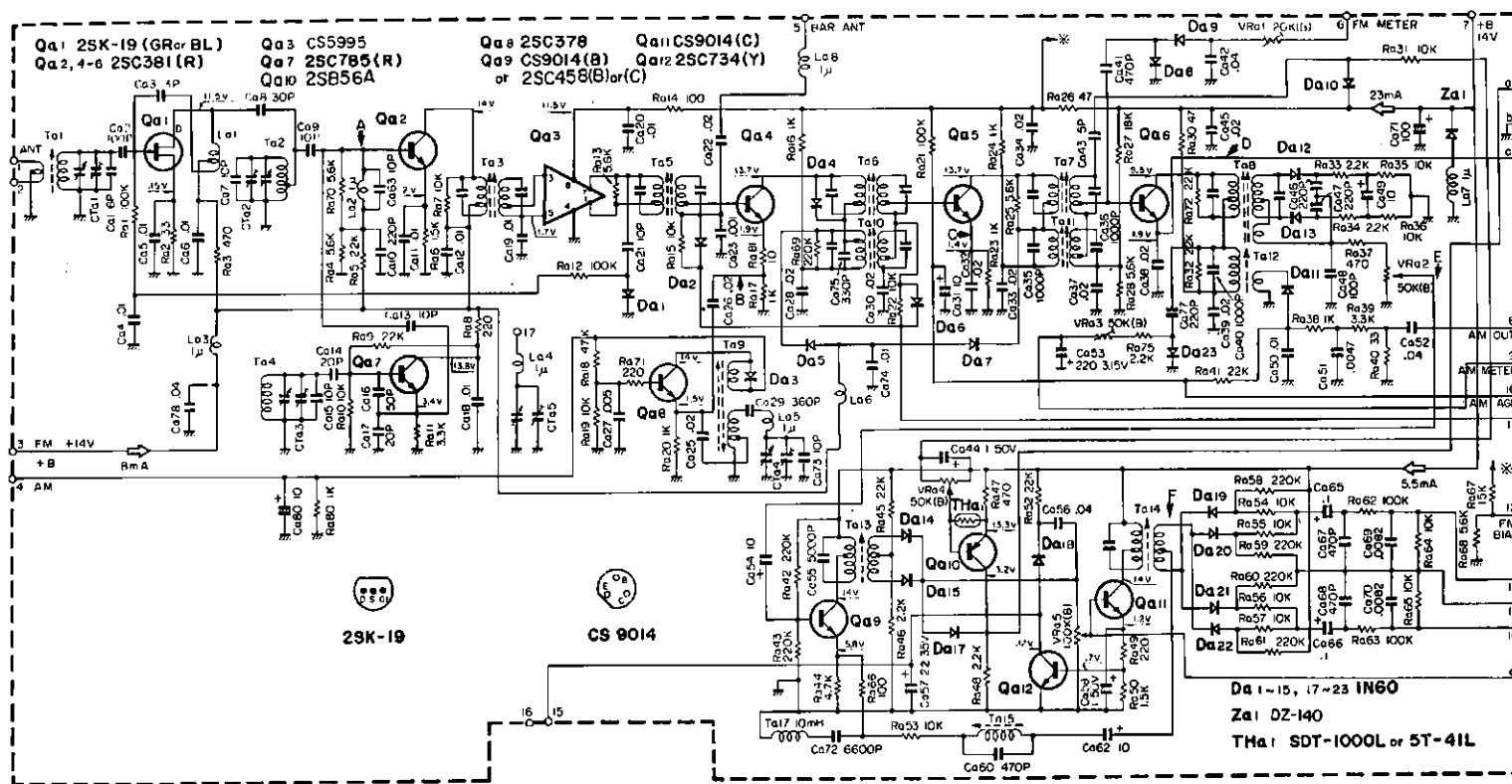

SCHEMATIC DIAGRAM

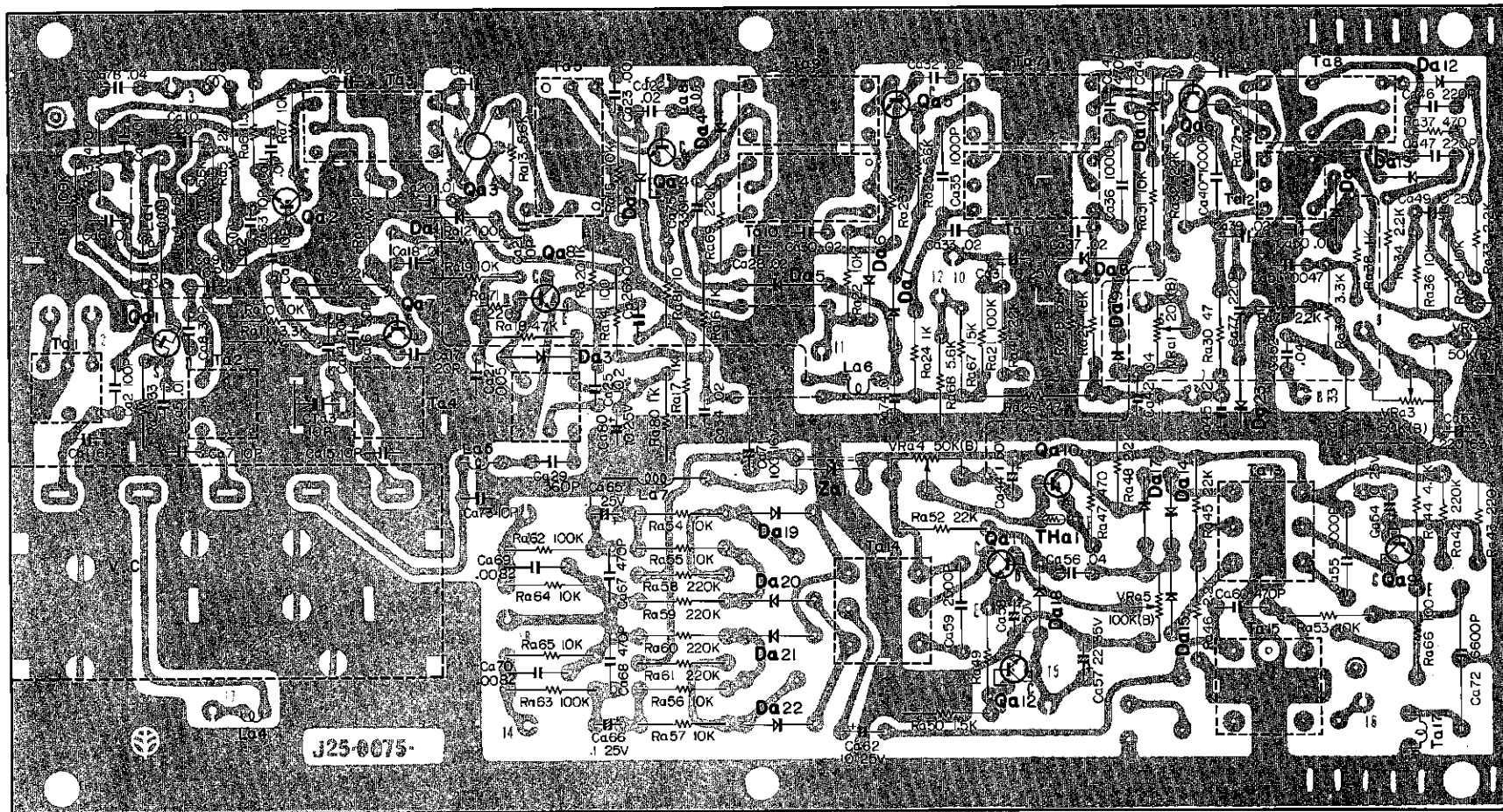

Qa1: 2SK19(GR or BL), Qa2, 4-6: 2SC381(R), Qa3: CS5995(R or B), Qa7: 2SC785(R), Qa9: CS9014(B) or 2SC458L(B or LC), Qa10: 2SB56A, Qa11: CS9014(C) or 2SC458L, Qa12: 2SC734(Y)
 Da1, 2, 4-15, 17-23: IN60 or IN34A, Za1: ZB1-14, THa1: SDT-1000L or 5T-41L

BOTTOM VIEW
 OF
 TRANSISTOR

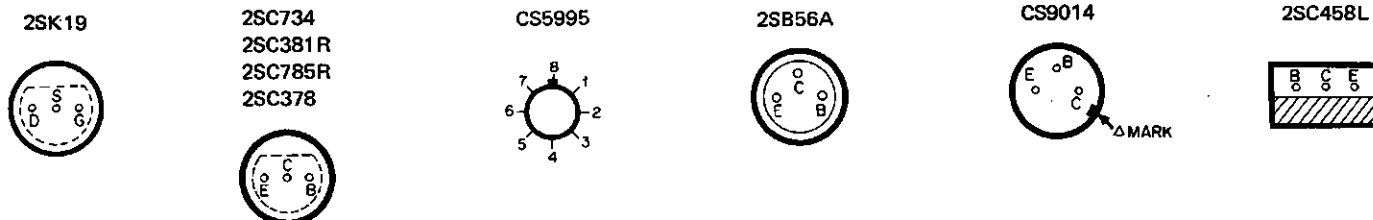

PARTS DESCRIPTION LIST

Circuit No.	Parts No.	Description	Re- marks
Ca1	CC94SL1H060D	TC ceramic 6pF ±0.5pF	
Ca2	CC94SL1H101K	TC ceramic 100pF ±10%	
Ca3	CC94SL1H030C	TC ceramic 3pF ±0.25pF	
Ca4~6	CK94YG1E103Z	Ceramic 0.01μF ±80%, -20%	
Ca7	CC94TH1H100D	TC ceramic 10pF ±10%	
Ca8	CC94SH1H300K	TC ceramic 30pF ±10%	
Ca9	CC94SL1H100D	TC ceramic 10pF ±0.5pF	
Ca10	CC94YX1H221K	TC ceramic 220pF ±10%	
Ca11, 12	CK94YG1E103Z	Ceramic 0.01μF ±80%, -20%	
Ca13	CC94TH1H100D	TC ceramic 10pF ±0.5pF	
Ca14	CC94RG1H200K	TC ceramic 20pF ±10%	
Ca15	CC94SG1H100D	TC ceramic 10pF ±0.5pF	
Ca16	CC94TH1H500K	TC ceramic 50pF ±10%	
Ca17	CC94TH1H200K	TC ceramic 20pF ±10%	
Ca18~20	CK94YG1E103Z	Ceramic 0.01μF ±80%, -20%	
Ca21	CC94SL1H100D	TC ceramic 10pF ±0.5pF	
Ca22	CK94YG1E203Z	Ceramic 0.02μF ±80%, -20%	
Ca23	CK94YX1H102M	Ceramic 0.001μF ±20%	
Ca25, 26	CK94YG1E203Z	Ceramic 0.02μF ±80%, -20%	
Ca27	CK94YG1E502Z	Ceramic 0.005μF ±80%, -20%	
Ca28	CK94YG1E203Z	Ceramic 0.02μF ±80%, -20%	
Ca29	CK94YX1H361K	Ceramic 360pF ±10%	
Ca30	CK94YG1E203Z	Ceramic 0.02μF ±80%, -20%	
Ca31	CE04WE1E100	PC electrolytic 10μF 25WV	
Ca32~34	CK94YG1E203Z	Ceramic 0.02μF ±80%, -20%	
Ca35, 36	CC08S2B102J	Polystyrene 1000pF ±5%	
Ca37~39	CK94YG1E203Z	Ceramic 0.02μF ±80%, -20%	
Ca40	CC08S2B102J	Polystyrene 1000pF ±5%	
Ca41	CK94YX1H471K	Ceramic 470pF ±10%	
Ca42	CK94YG1E403Z	Ceramic 0.04μF ±80%, -20%	
Ca43	CC94SL1H050D	TC ceramic 50pF ±0.5pF	
Ca44	CE04W1H010	PC electrolytic 1μF 50WV	
Ca45	CK94YG1E203Z	Ceramic 0.02μF ±80%, -20%	
Ca46, 47	CC94SL1H221K	TC ceramic 220pF ±10%	
Ca48	CC94SL1H101K	TC ceramic 100pF ±10%	
Ca49	CE04WE1E100	PC electrolytic 10μF 25WV	
Ca50	CK94YX1H103M	Ceramic 10μF ±20%	
Ca51	CK94YX1H472M	Ceramic 0.047μF ±20%	
Ca52	CK94YG1E403Z	Ceramic 0.04μF ±80%, -20%	
Ca53	CE04W0J221	PC electrolytic 220μF 6.3WV	
Ca54	CE04W1E100	PC electrolytic 10μF 25WV	
Ca55	CC08S2B502J	Polystyrene 5000pF ±5%	
Ca56	CK94YG1E403Z	Ceramic 0.04μF ±80%, -20%	
Ca57	CE04W1V220	PC electrolytic 22μF 35WV	
Ca58	CE04W1H010	PC electrolytic 1μF 50WV	
Ca59	CC08S2B252J	Polystyrene 2500pF ±5%	
Ca60	CM93D1H471J(Z)	Polystyrene 470pF ±5%	
Ca62	CE04WE1E100	PC electrolytic 10μF 25WV	
Ca63	CC94SL1H100D	TC ceramic 10pF ±0.5pF	
Ca65, 66	CA06E1E410M	Solid aluminum 0.1μF 25WV	
Ca67, 68	CK94YX1H471K	Ceramic 470pF ±10%	
Ca69, 70	CC93M1H822J	Mylar 0.0082μF ±5%	
Ca71	CE04WC101	PC electrolytic 100μF 16WV	
Ca72	CC08S2B662J	Polystyrene 6600pF ±5%	
Ca73	CC94TH1H100D	TC ceramic 10pF ±0.5pF	
Ca74	CK94YX1H103M	Ceramic 0.01μF ±20%	
Ca75	CM93D1H331J(Z)	Polystyrene 330pF ±5%	
Ca77	CC94SL1H221K	TC ceramic 220pF ±10%	
Ca78	CK94YG1E403Z	Ceramic 0.04μF ±80%, -20%	
Ca80	CE04WE1E100	PC electrolytic 10μF 25WV	
Ca83	CTa3	Ceramic trimmer (10pF)	
Ra1	PD14BY2E104J	Insulated carbon film 100kΩ ±5%	
Ra2	PD14BY2E330J	Insulated carbon film 33Ω ±5%	
Ra3	PD14BY2E471J	Insulated carbon film 470Ω ±5%	
Ra4	PD14BY2E562J	Insulated carbon film 5.6kΩ ±5%	
Ra5	PD14BY2E223J	Insulated carbon film 22kΩ ±5%	
Ra6	PD14BY2E152J	Insulated carbon film 1.5kΩ ±5%	
Ra7	PD14BY2E103J	Insulated carbon film 10kΩ ±5%	
Ra8	PD14BY2E221J	Insulated carbon film 220Ω ±5%	
Ra9	PD14BY2E223J	Insulated carbon film 22kΩ ±5%	
Ra10	PD14BY2E103J	Insulated carbon film 10kΩ ±5%	
Ra11	PD14BY2E332J	Insulated carbon film 3.3kΩ ±5%	
Ra12	PD14BY2E104J	Insulated carbon film 100kΩ ±5%	
Ra13	PD14BY2E562J	Insulated carbon film 5.6kΩ ±5%	
Ra14	PD14BY2E101J	Insulated carbon film 100Ω ±5%	
Ra15	PD14BY2E103J	Insulated carbon film 10kΩ ±5%	
Ra16, 17	PD14BY2E102J	Insulated carbon film 1kΩ ±5%	
Ra18	PD14BY2E473J	Insulated carbon film 47kΩ ±5%	
Ra19	PD14BY2E103J	Insulated carbon film 10kΩ ±5%	
Ra20	PD14BY2E102J	Insulated carbon film 1kΩ ±5%	
Ra21	PD14BY2E104J	Insulated carbon film 100kΩ ±5%	
Ra22	PD14BY2E103J	Insulated carbon film 10kΩ ±5%	
Ra23, 24	PD14BY2E102J	Insulated carbon film 1kΩ ±5%	
Ra25	PD14BY2E562J	Insulated carbon film 5.6kΩ ±5%	
Ra26	PD14BY2E470J	Insulated carbon film 47Ω ±5%	
Ra27	PD14BY2E183J	Insulated carbon film 18kΩ ±5%	
Ra28	PD14BY2E562J	Insulated carbon film 5.6kΩ ±5%	

Circuit No.	Parts No.	Description
Ra30	PD14BY2E470J	Insulated carbon film 47Ω ±5%
Ra31	PD14BY2E103J	Insulated carbon film 10kΩ ±5%
Ra32	PD14BY2E222J	Insulated carbon film 2.2kΩ ±5%
Ra33, 34	PD14BY2E222J	Insulated carbon film 2.2kΩ ±5%
Ra35, 36	PD14BY2E103J	Insulated carbon film 10kΩ ±5%
Ra37	PD14BY2E471J	Insulated carbon film 470Ω ±5%
Ra38	PD14BY2E102J	Insulated carbon film 1kΩ ±5%
Ra39	PD14BY2E332J	Insulated carbon film 3.3kΩ ±5%
Ra40	PD14BY2E330J	Insulated carbon film 33Ω ±5%
Ra41	PD14BY2E223J	Insulated carbon film 22kΩ ±5%
Ra42, 43	PD14BY2E224J	Insulated carbon film 220kΩ ±5%
Ra44	PD14BY2E472J	Insulated carbon film 4.7kΩ ±5%
Ra45	PD14BY2E223J	Insulated carbon film 22kΩ ±5%
Ra46	PD14BY2E222J	Insulated carbon film 2.2kΩ ±5%
Ra47	PD14BY2E471J	Insulated carbon film 470Ω ±5%
Ra48	PD14BY2E222J	Insulated carbon film 2.2kΩ ±5%
Ra49	PD14BY2E331J	Insulated carbon film 330Ω ±5%
Ra50	PD14BY2E152J	Insulated carbon film 1.5kΩ ±5%
Ra52	PD14BY2E223J	Insulated carbon film 22kΩ ±5%
Ra53~57	PD14BY2E103J	Insulated carbon film 10kΩ ±5%
Ra58~61	PD14BY2E224J	Insulated carbon film 220kΩ ±5%
Ra62, 63	PD14BY2E104J	Insulated carbon film 100kΩ ±5%
Ra64, 65	PD14BY2E103J	Insulated carbon film 10kΩ ±5%
Ra66	PD14BY2E101J	Insulated carbon film 100Ω ±5%
Ra67	PD14BY2E153J	Insulated carbon film 15kΩ ±5%
Ra68	PD14BY2E562J	Insulated carbon film 5.6kΩ ±5%
Ra69	PD14BY2E562J	Insulated carbon film 5.6kΩ ±5%
Ra70	PD14BY2E562J	Insulated carbon film 5.6kΩ ±5%
Ra71	PD14BY2E331J	Insulated carbon film 330Ω ±5%
Ra72	PD14BY2E223J	Insulated carbon film 22kΩ ±5%
Ra75	PD14BY2E222J	Insulated carbon film 2.2kΩ ±5%
Ra76	PD14BY2E102J	Insulated carbon film 1kΩ ±5%
Ra80	PD14BY2E102J	Insulated carbon film 1kΩ ±5%
Ra81	PD14BY2E100J	Insulated carbon film 10Ω ±5%
La1	L33-0027-05	Choke coil
La2	L33-0002-04	Choke coil
La3~6	L33-0086-05	Ferrite inductor
La7	L33-0025-05	Choke coil
La8	L33-0086-05	Ferrite inductor
La1	L34-0348-04	FM ANT coil
La2	L34-0056-04	FM RF coil
La3	L30-0150-05	FM IFT
La4	L34-0057-04	FM OSC coil
La5	L30-0151-05	FM IFT
La6	L30-0152-05	FM IFT
La7	L30-0153-05	FM IFT
La8	L30-0137-05	FM IFT
La9	L30-0082-05	AM OSC
La10	L30-0089-05	AM IFT
La11	L30-0081-05	FM IFT
La12	L30-0052-05	AM IFT
La13	L35-0035-05	19kHz coil
La14	L35-0036-05	38kHz coil
La15	L35-0030-05	72kHz coil
Ta17	L33-0117-05	Ferrite inductor
Qa1	ZSK-19 (GR or BL)	
Qa2	ZSC381R	
Qa3	CS5995 (R or B)	
Qa4~6	ZSC381R	
Qa7	ZSC785R	
Qa8	ZSC378	
Qa9	CS9014B (ZSC458L, B or C)	
Qa10	ZSB56A	
Qa11	CS9014C (ZSC485L, C)	
Qa12	ZSC734V	
Da1~5, 17~23	DZ-140 1N60 or 1N34A (YELLOW)	
Za1	SDT-1000L or ST-41L	
THa1		
MISCELLANEOUS		
	J25-0075-12	PC board
	CO1-0137-05	Variable capacitor
	F10-0049-03	Shield board A
	F10-0004-04	Shield board B
	F10-0187-04	Shield board C

SCHEMATIC DIAGRAM

BOTTOM VIEW OF TRANSISTOR

2SC458LG

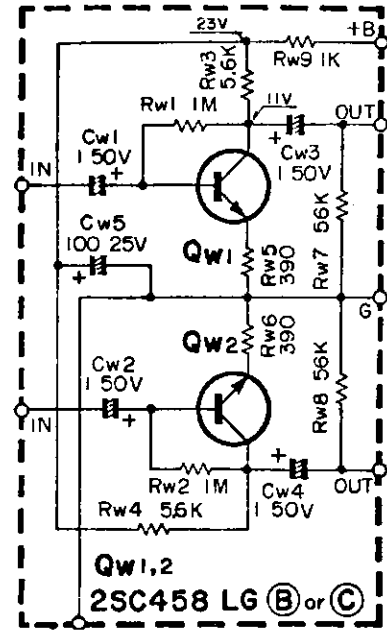
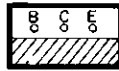

SEALED CIRCUIT ASSEMBLIES PHANTOM VIEWS

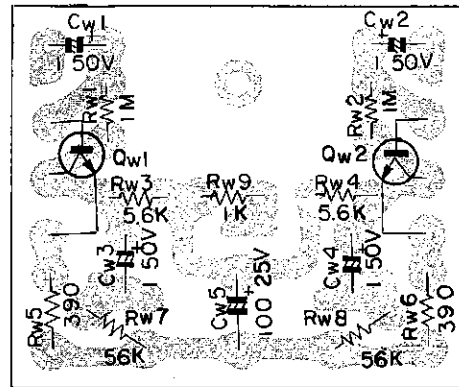

Qw1, 2 2SC 458LG (B) or (C)

**PARTS DESCRIPTION LIST**

Circuit No.	Parts No.	Description				Remarks
CAPACITOR						
Cd(W)1~4	CE04W1H010	PC electrolytic	1 μ F	50WV		
Cd(W)5	CE04W1E101	PC electrolytic	100 μ F	25WV		
RESISTOR						
Rd(W)1, 2	RC05GF2H105K	Carbon composition	1M Ω	\pm 10%	1/2W	
Rd(W)3, 4	PD14CY2E562J	Insulated carbon film	5.6k Ω	\pm 5%	1/4W	
Rd(W)5, 6	PD14CY2E391J	Insulated carbon film	390 Ω	\pm 5%	1/4W	
Rd(W)7, 8	PD14CY2E563K	Insulated carbon film	56k Ω	\pm 10%	1/4W	
Rd(W)9	PD14CY2E102K	Insulated carbon film	1k Ω	\pm 10%	1/4W	
TRANSISTOR/PC BOARD						
Qd(S)1, 2 —	J25-0079-04	2SC458LG(B) or (C) PC board				

SCHEMATIC DIAGRAM

BOTTOM VIEW OF TRANSISTOR

2SC458LG

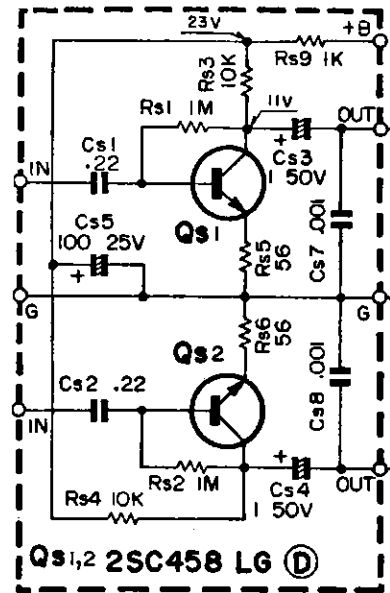
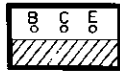

SEALED CIRCUIT ASSEMBLIES PAHNTOM VIEWS

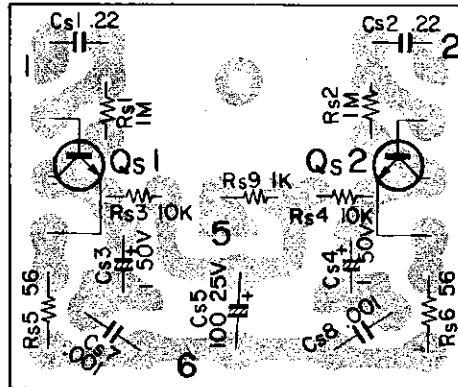

Qs1, 2 2SC458LG (D)

PARTS DESCRIPTION LIST

Circuit No.	Parts No.	Description			Remarks
CAPACITOR					
Cs1, 2	CS04D1ER22MorX	Tantalum	0.22 μ F	25WV	
Cs3, 4	CE04W1H010	PC electrolytic	1 μ F	50WV	
Cs5	CE04W1E101	PC electrolytic	100 μ F	25WV	
Cs7, 8	CK94YY1H102M	Ceramic	0.001 μ F	\pm 20%	
RESISTOR					
Rs1, 2	RC05GF2H105K	Carbon composition	1M Ω	\pm 10%	1/2W
Rs3, 4	PD14CY2E103J	Insulated carbon film	10k Ω	\pm 5%	1/4W
Rs5, 6	PD14CY2E560J	Insulated carbon film	56 Ω	\pm 5%	1/4W
Rs9	PD14CY2E102K	Insulated carbon film	1k Ω	\pm 10%	1/4W
TRANSISTOR/PC BOARD					
Qs1, 2	J25-0077-04	2SC458LG (D)			
-		PC board			

SCHEMATIC DIAGRAM

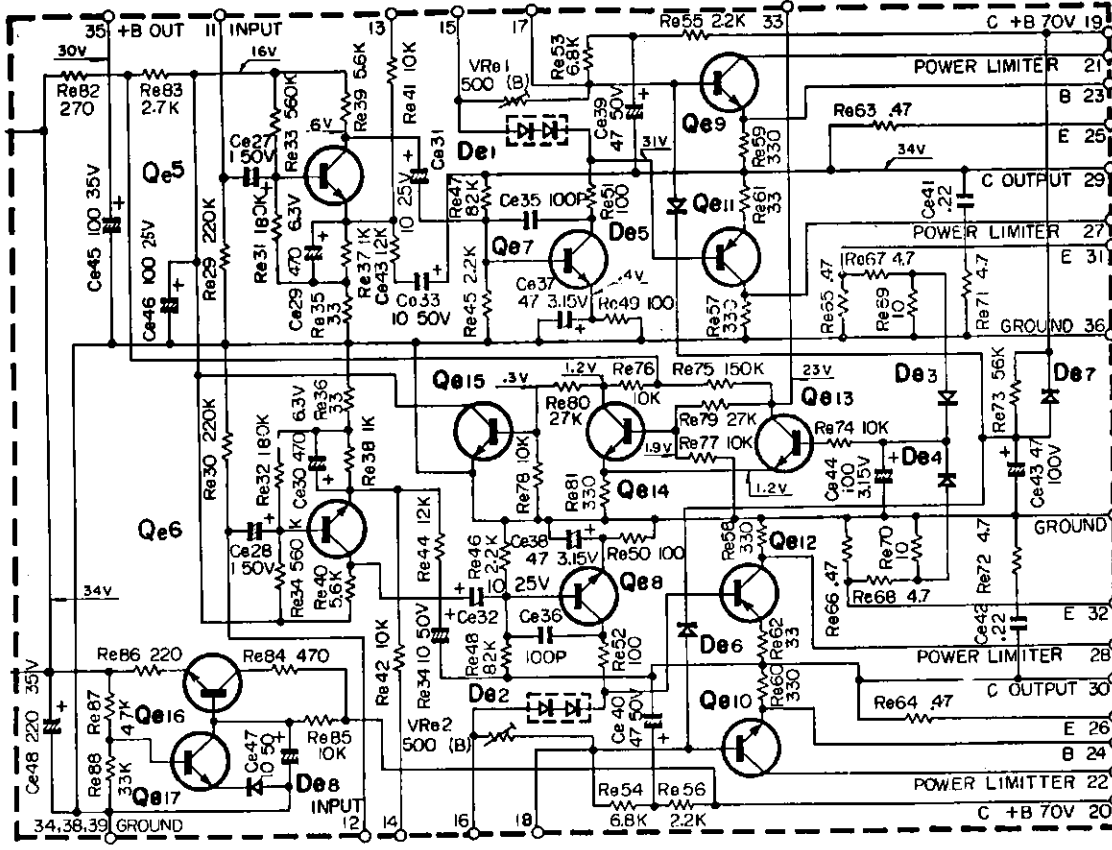
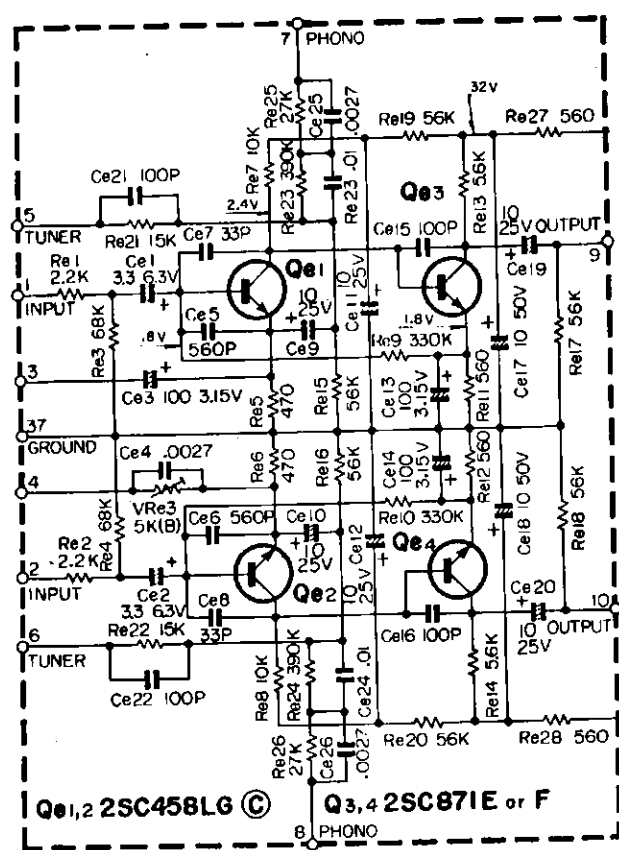

BOTTOM VIEW OF TRANSISTOR

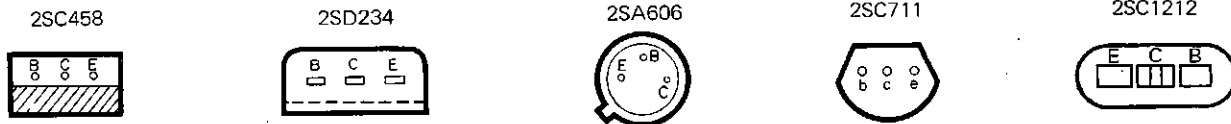

SEALED CIRCUIT ASSEMBLIES PHANTOM VIEWS

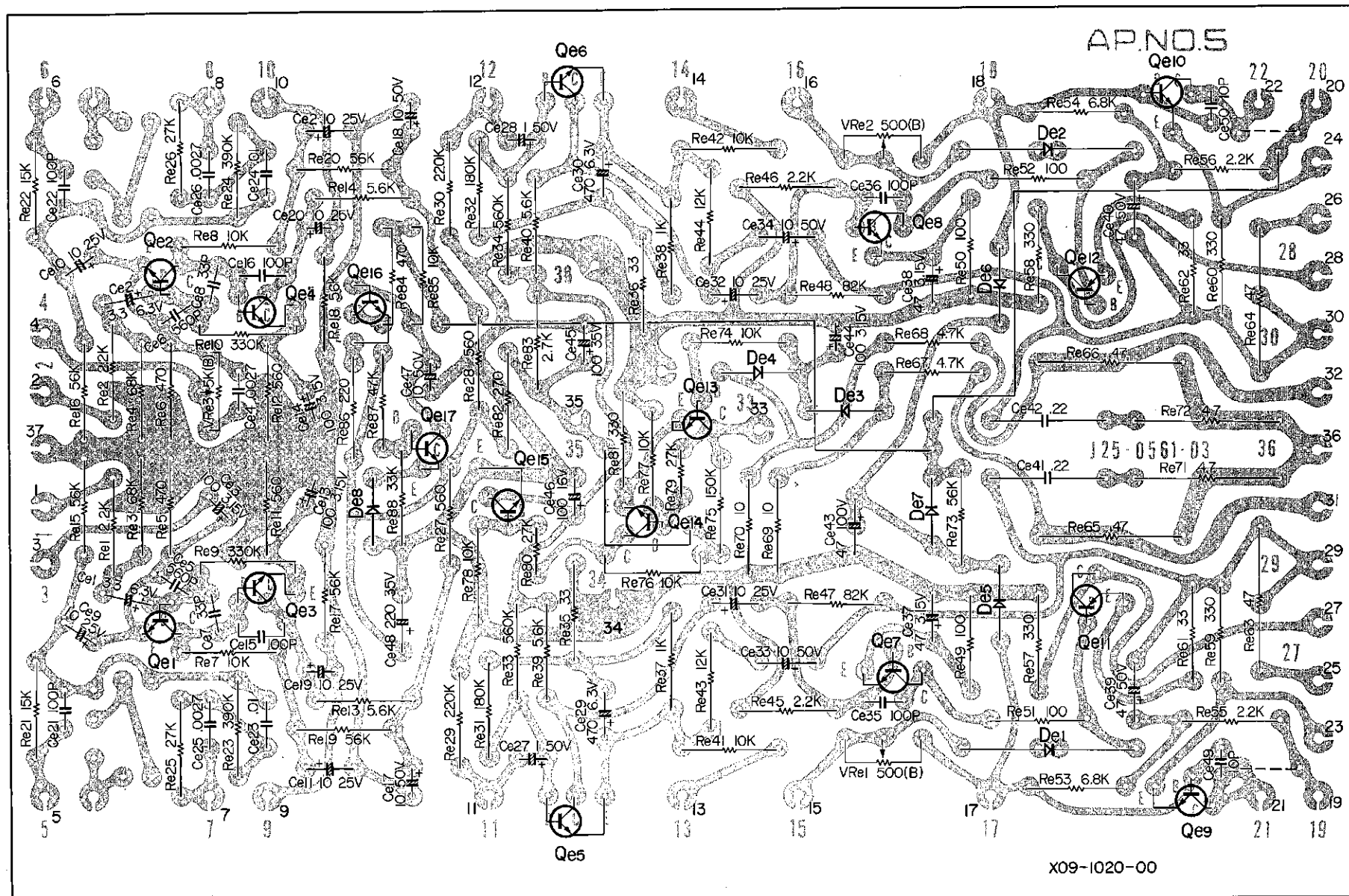

Qe1,2: 2SC458LG(C), Qe3,4: 2SC871E or F, Qe5,6: 2SC458LG(C) or (D), Qe7,8: 2SC1212A(C), Qe9,10: 2SC1212A(B) or (C), Qe11,12: 2SA606, Qe13,14: 2SC458(B) or (C), Qe15: 2SC734(O) or (Y), Qe16: 2SD234(O) or (Y), Qe17: 2SC711A(E), De1,2: MV-13, De3,4: 1N60, De5,6,7: 1S1553V, De8: 1S338T

Circuit No.	Parts No.	Description	Remarks
Ca1, 2	CS04D0J3R3M	Tantalum	
Ca3	CE04W0F101	PC electrolytic	
Ca4	CG93M1H272K	Mylar	
Ca5, 6	CK94Y1H581M	Ceramic	
Ca7, 8	CG94SL1H330K	TC ceramic	
Ca9~12	CE04W1E100	PC electrolytic	
Ca13, 14	CE04W0F101	PC electrolytic	
Ca15, 16	CS94SL1H101K	TC ceramic	
Ca17, 18	CE04W1H100	PC electrolytic	
Ca19, 20	CE04W1E100	PC electrolytic	
Ca21, 22	CG94SL1H101K	TC ceramic	
Ca23, 24	CG93M1H103K	Mylar	
Ca25, 26	CG93M1H272K	Mylar	
Ca27, 28	CE04W1H010	PC electrolytic	
Ca29, 30	CE04W0J471	PC electrolytic	
Ca31, 32	CE04W1E100	PC electrolytic	
Ca33, 34	CE04W1H100	PC electrolytic	
Ca35, 36	CG94SL1H101K	TC ceramic	
Ca37, 38	CE04W0F470	PC electrolytic	
Ca39, 40	CE04W1H470	PC electrolytic	
Ca41, 42	CG93M1H224M	Mylar	
Ca43	CE04W2A470	PC electrolytic	
Ca44	CE04W0F101	PC electrolytic	
Ca45	CE04W1V101	PC electrolytic	
Ca46	CE04W1E101	PC electrolytic	
Ca47	CE04W1H100	PC electrolytic	
Ca48	CE04W1V221	PC electrolytic	
Ra1, 2	PD14BY2E222J	Insulated carbon film	±5% 1/4W
Ra3, 4	PD14BY2E683J	Insulated carbon film	±5% 1/4W
Ra5, 6	PD14BY2E471J	Insulated carbon film	±5% 1/4W
Ra7, 8	PD14BY2E103J	Insulated carbon film	±5% 1/4W
Ra9, 10	PD14BY2E334J	Insulated carbon film	±5% 1/4W
Ra11, 12	PD14BY2E561J	Insulated carbon film	±5% 1/4W
Ra13, 14	PD14BY2E562J	Insulated carbon film	±5% 1/4W
Ra15~20	PD14BY2E563J	Insulated carbon film	±5% 1/4W
Ra21, 22	PD14BY2E153J	Insulated carbon film	±5% 1/4W
Ra23, 24	PD14BY2E394J	Insulated carbon film	±5% 1/4W
Ra25, 26	PD14BY2E273J	Insulated carbon film	±5% 1/4W
Ra27, 28	PD14BY2E561J	Insulated carbon film	±5% 1/4W
Ra29, 30	PD14BY2E224J	Insulated carbon film	±5% 1/4W
Ra31, 32	PD14BY2E184J	Insulated carbon film	±5% 1/4W
Ra33, 34	PD14BY2E564J	Insulated carbon film	±5% 1/4W
Ra35, 36	PD14BY2E330J	Insulated carbon film	±5% 1/4W
Ra37, 38	PD14BY2E102J	Insulated carbon film	±5% 1/4W
Ra39, 40	PD14BY2E562J	Insulated carbon film	±5% 1/4W
Ra41, 42	PD14BY2E103J	Insulated carbon film	±5% 1/4W
Ra43, 44	PD14BY2E123J	Insulated carbon film	±5% 1/4W
Ra45, 46	PD14BY2E222J	Insulated carbon film	±5% 1/4W
Ra47, 48	PD14BY2E823J	Insulated carbon film	±5% 1/4W
Ra49~52	PD14BY2E101J	Insulated carbon film	±5% 1/4W
Ra53, 54	PD14BY2E682J	Insulated carbon film	±5% 1/4W
Ra55, 56	PD14BY2E222J	Insulated carbon film	±5% 1/4W
Ra57~60	PD14BY2E331J	Insulated carbon film	±5% 1/4W
Ra61, 62	PD14BY2E330J	Insulated carbon film	±5% 1/4W
Ra63~66	RN14A3D47K	Metal film	±10% 1W
Ra67, 68	RC05GF2H47K	Carbon composition	±10% 1/2W
Ra69, 70	PD14BY2E100J	Insulated carbon film	±5% 1/4W
Ra71, 72	RN14A3D47K	Metal film	±10% 1W
Ra73	PD14BY2E563J	Insulated carbon film	±5% 1/4W
Ra74	PD14BY2E103J	Insulated carbon film	±5% 1/4W
Ra75	PD14BY2E154J	Insulated carbon film	±5% 1/4W
Ra76~78	PD14BY2E103J	Insulated carbon film	±5% 1/4W
Ra79, 80	PD14CY2E273J	Insulated carbon film	±5% 1/4W
Ra81	PD14BY2E331J	Insulated carbon film	±5% 1/4W
Ra82	PD14BY2E271J	Insulated carbon film	±5% 1/4W
Ra83	PD14BY2E272J	Insulated carbon film	±5% 1/4W
Ra84	RC05GF2H471K	Carbon composition	±10% 1/2W
Ra85	PD14BY2E103J	Insulated carbon film	±5% 1/4W
Ra86	RC05GF2H221K	Carbon composition	±10% 1/2W
Ra87	PD14BY2E473J	Insulated carbon film	±5% 1/4W
Ra88	PD14BY2E333J	Insulated carbon film	±5% 1/4W
Qa1, 2	2SC458LG (C)	Insulated carbon film	±5% 1/4W
Qa3, 4	2SC871 (E) or (F)	Insulated carbon film	±5% 1/4W
Qa5, 6	2SC458LG (C) or (D)	Insulated carbon film	±5% 1/4W
Qa7, 8	2SC1212A (C)	Insulated carbon film	±5% 1/4W
Qa9, 10	2SC1212A (B) or (C)	Insulated carbon film	±5% 1/4W
Qa11, 12	2SA606	Insulated carbon film	±5% 1/4W
Qa13, 14	2SC458 (B) or (C)	Insulated carbon film	±5% 1/4W
Qa15	2SC734 (O) or (Y)	Insulated carbon film	±5% 1/4W
Qa16	2SD234 (O) or (Y)	Insulated carbon film	±5% 1/4W
Qa17	2SC711A (E)	Insulated carbon film	±5% 1/4W
Da1, 2	MV-13	Insulated carbon film	±5% 1/4W
Da3, 4	1N60	Insulated carbon film	±5% 1/4W
Da5~7	1S153V	Insulated carbon film	±5% 1/4W
Da8	1S338T	Insulated carbon film	±5% 1/4W
VRa1, 2	R12-0039-05	PC trimmer potentiometer 500Ω (B)	
VRa3	R12-2015-05	PC trimmer potentiometer 5kΩ (B)	
-	J26-0561-03	PC board	
POTENTIOMETER/PC BOARD			
TRANSISTOR/DIODES			
RESISTOR			
CAPACITOR			

SCHEMATIC DIAGRAM

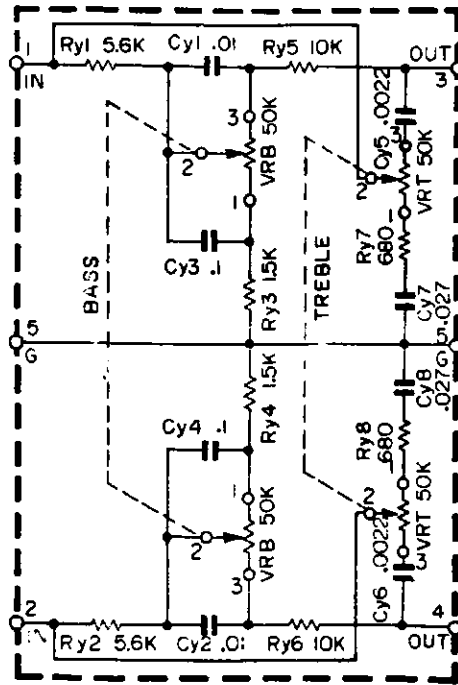

SEALED CIRCUIT ASSEMBLIES PHANTOM VIEWS

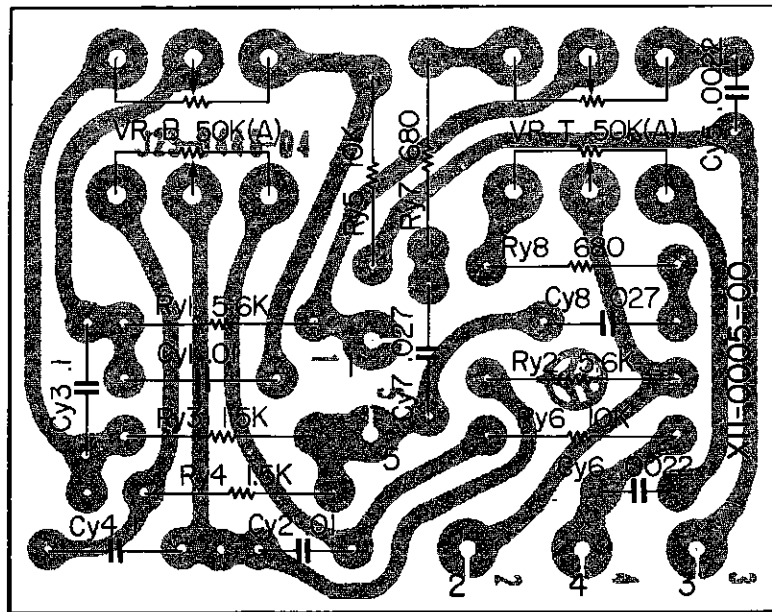

**KENWOOD****MULTI PRESENCE (XII-0005-01) SECTION****PARTS DESCRIPTION LIST**

Circuit No.	Parts No.	Description				Remarks
CAPACITOR						
Cy1, 2	CQ93M1H103K	Mylar	0.01 μ F	\pm 10%		
Cy3, 4	CQ93M1H104K	Mylar	0.1 μ F	\pm 10%		
Cy5, 6	CQ93M1H222K	Mylar	0.0022 μ F	\pm 10%		
Cy7, 8	CQ93M1H273K	Mylar	0.027 μ F	\pm 10%		
RESISTOR						
Ry1, 2	PD14BY2E562J	Insulated carbon film	5.6k Ω	\pm 5%	1/4W	
Ry3, 4	PD14BY2E152J	Insulated carbon film	1.5k Ω	\pm 5%	1/4W	
Ry5, 6	PD14BY2E103J	Insulated carbon film	10k Ω	\pm 5%	1/4W	
Ry7, 8	PD14BY2E681J	Insulated carbon film	680 Ω	\pm 5%	1/4W	
POTENTIOMETER/PC BOARD						
VRB	R06-4006-05	BASS 50k Ω (A) dual				
VRT	R06-4006-05	TREBLE 50k Ω (A) dual				
-	J25-0446-14	PC board				

SCHEMATIC DIAGRAM

BOTTOM VIEW OF TRANSISTOR

2SC871

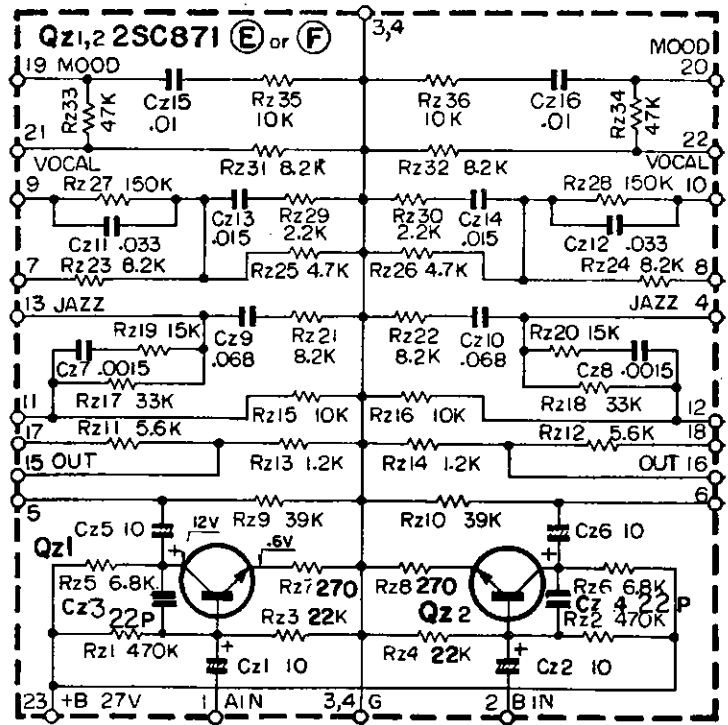
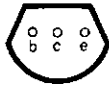

SEALED CIRCUIT ASSEMBLIES PHANTOM VIEWS

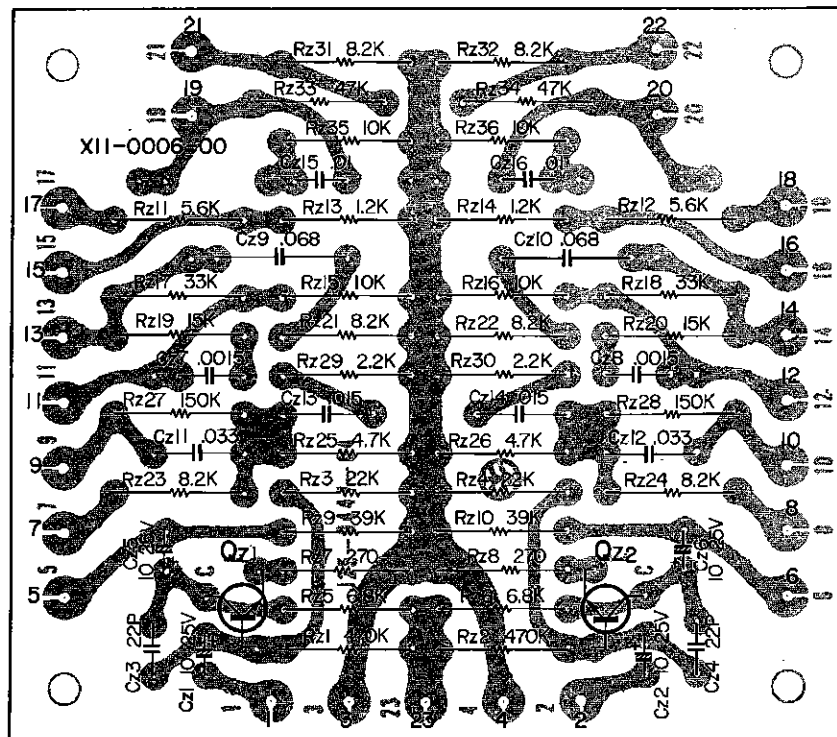

Qz1, 2 2SC871 (E) or (F)

**KENWOOD****MULTI PRESENCE (XII-0006-00) SECTION****PARTS DESCRIPTION LIST**

Circuit No.	Parts No.	Description			Remarks
CAPACITOR					
Cz1, 2	CE04W1E100	PC electrolytic	10 μ F	25WV	
Cz3, 4	CC94SL1H220K	TC ceramic	22pF	\pm 10%	
Cz5, 6	CE04W1E100	PC electrolytic	10 μ F	25WV	
Cz7, 8	CQ93M1H152K	Mylar	0.0015 μ F	\pm 10%	
Cz9, 10	CQ93M1H683K	Mylar	0.068 μ F	\pm 10%	
Cz11, 12	CQ93M1H333K	Mylar	0.033 μ F	\pm 10%	
Cz13, 14	CQ93M1H153K	Mylar	0.015 μ F	\pm 10%	
Cz15, 16	CQ93M1H103K	Mylar	0.01 μ F	\pm 10%	
RESISTOR					
Rz1, 2	PD14BY2E474J	Insulated carbon film	470k Ω	\pm 5%	1/4W
Rz3, 4	PD14BY2E223J	Insulated carbon film	22k Ω	\pm 5%	1/4W
Rz5, 6	PD14BY2E682J	Insulated carbon film	6.8k Ω	\pm 5%	1/4W
Rz7, 8	PD14BY2E271J	Insulated carbon film	270 Ω	\pm 5%	1/4W
Rz9, 10	PD14BY2E393J	Insulated carbon film	390k Ω	\pm 5%	1/4W
Rz11, 12	PD14BY2E562J	Insulated carbon film	5.6k Ω	\pm 5%	1/4W
Rz13, 14	PD14BY2E122J	Insulated carbon film	1.2k Ω	\pm 5%	1/4W
Rz15, 16	PD14BY2E103J	Insulated carbon film	10k Ω	\pm 5%	1/4W
Rz17, 18	PD14BY2E333J	Insulated carbon film	33k Ω	\pm 5%	1/4W
Rz19, 20	PD14BY2E153J	Insulated carbon film	15k Ω	\pm 5%	1/4W
Rz21~24	PD14BY2E822J	Insulated carbon film	8.2k Ω	\pm 5%	1/4W
Rz25, 26	PD14BY2E472J	Insulated carbon film	4.7k Ω	\pm 5%	1/4W
Rz27, 28	PD14BY2E154J	Insulated carbon film	150k Ω	\pm 5%	1/4W
Rz29, 30	PD14BY2E222J	Insulated carbon film	2.2k Ω	\pm 5%	1/4W
Rz31, 32	PD14BY2E822J	Insulated carbon film	8.2k Ω	\pm 5%	1/4W
Rz33, 34	PD14BY2E473J	Insulated carbon film	47k Ω	\pm 5%	1/4W
Rz35, 36	PD14BY2E103J	Insulated carbon film	10k Ω	\pm 5%	1/4W
TRANSISTOR/PC BOARD					
Qz1, 2	J25-0447-04	2SC871(E) or (F)			
—		PC board			

SCHEMATIC DIAGRAM

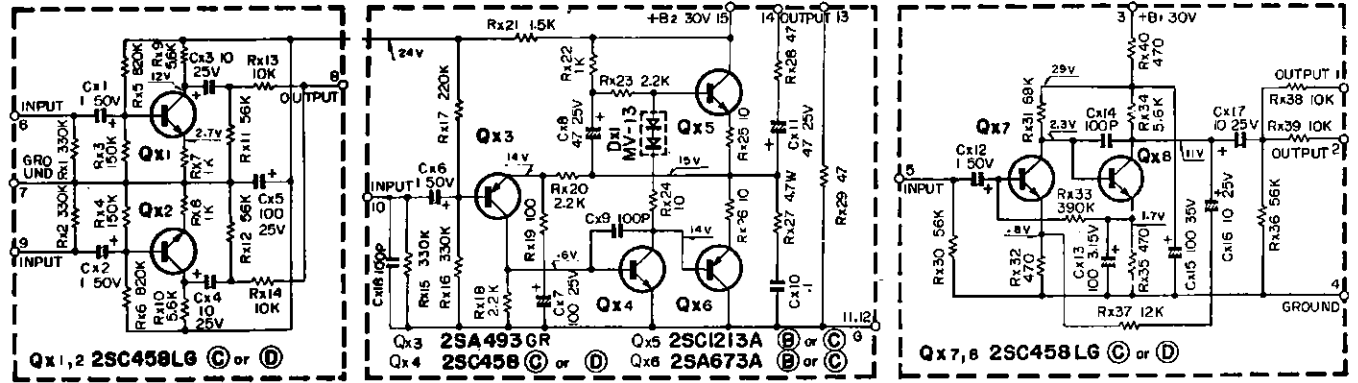

BOTTOM VIEW OF TRANSISTOR

2SA673A
2SC458
2SC1213

2SA493

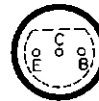

SEALED CIRCUIT ASSEMBLIES PHANTOM VIEWS

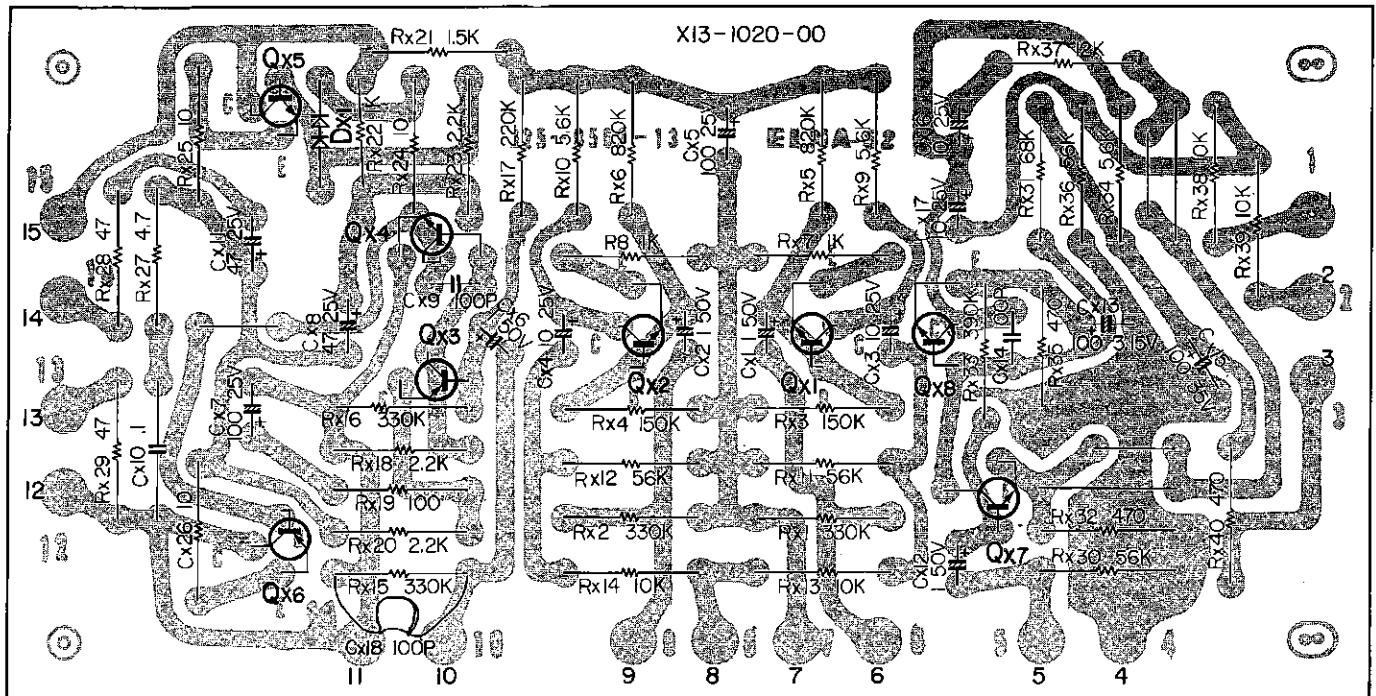

Qx1,2,7,8: 2SC458LG (C) or (D), Qx3: 2SA493GR, Qx4: 2SC458(C) or (D), Qx5: 2SC1213A(B) or (C), Qx6: 2SA673A(B) or (C)
Dx1: MV-13

**PARTS DESCRIPTION LIST**

Circuit No.	Parts No.	Description			Remarks
CAPACITOR					
Cx1, 2	CE04W1H010	PC electrolytic	1 μ F	50WV	
Cx3, 4	CE04W1E100	PC electrolytic	10 μ F	25WV	
Cx5	CE04W1E101	PC electrolytic	100 μ F	25WV	
Cx6	CE04W1H010	PC electrolytic	1 μ F	50WV	
Cx7	CE04W1E101	PC electrolytic	100 μ F	25WV	
Cx8	CE04W1E470	PC electrolytic	47 μ F	25WV	
Cx9	CC94SL1H101K	TC ceramic	100pF	\pm 10%	
Cx10	CQ93M1H104M	Mylar	0.1 μ F	\pm 20%	
Cx11	CE04W1E470	PC electrolytic	47 μ F	25WV	
Cx12	CE04W1H010	PC electrolytic	1 μ F	50WV	
Cx13	CE04W0F101	PC electrolytic	100 μ F	3.15WV	
Cx14	CC94SL1H101K	TC ceramic	100pF	\pm 10%	
Cx15	CE04W1V101	PC electrolytic	100 μ F	35WV	
Cx16, 17	CE04W1E100	PC electrolytic	10 μ F	25WV	
Cx18	CC94SL1H101K	TC ceramic	100 μ F	\pm 10%	
RESISTOR					
Rx1, 2	PD14BY2E334J	Insulated carbon film	330k Ω	\pm 5%	1/4W
Rx3, 4	PD14BY2E154J	Insulated carbon film	150k Ω	\pm 5%	1/4W
Rx5, 6	PD14BY2E824J	Insulated carbon film	820k Ω	\pm 5%	1/4W
Rx7, 8	PD14BY2E102J	Insulated carbon film	1k Ω	\pm 5%	1/4W
Rx9, 10	PD14BY2E562J	Insulated carbon film	5.6k Ω	\pm 5%	1/4W
Rx11, 12	PD14BY2E563J	Insulated carbon film	56k Ω	\pm 5%	1/4W
Rx13, 14	PD14BY2E103J	Insulated carbon film	10k Ω	\pm 5%	1/4W
Rx15, 16	PD14BY2E334J	Insulated carbon film	330k Ω	\pm 5%	1/4W
Rx17	PD14BY2E224J	Insulated carbon film	220k Ω	\pm 5%	1/4W
Rx18	PD14BY2E222J	Insulated carbon film	2.2k Ω	\pm 5%	1/4W
Rx19	PD14BY2E101J	Insulated carbon film	100 Ω	\pm 5%	1/4W
Rx20	PD14BY2E222J	Insulated carbon film	2.2k Ω	\pm 5%	1/4W
Rx21	PD14BY2E152J	Insulated carbon film	1.5k Ω	\pm 5%	1/4W
Rx22	PD14BY2E102J	Insulated carbon film	1k Ω	\pm 5%	1/4W
Rx23	PD14BY2E222J	Insulated carbon film	2.2k Ω	\pm 5%	1/4W
Rx24	PD14BY2E100J	Insulated carbon film	10 Ω	\pm 5%	1/4W
Rx25, 26	RC05GF2H100K	Carbon composition	10 Ω	\pm 10%	1/2W
Rx27	RC05GF2H4R7K	Carbon composition	4.7 Ω	\pm 10%	1/2W
Rx28, 29	RC05GF2H470K	Carbon composition	47 Ω	\pm 10%	1/2W
Rx30	PD14BY2E563J	Insulated carbon film	56k Ω	\pm 5%	1/4W
Rx31	PD14BY2E683J	Insulated carbon film	68k Ω	\pm 5%	1/4W
Rx32	PD14BY2E471J	Insulated carbon film	470 Ω	\pm 5%	1/4W
Rx33	PD14BY2E394J	Insulated carbon film	390k Ω	\pm 5%	1/4W
Rx34	PD14BY2E562J	Insulated carbon film	5.6k Ω	\pm 5%	1/4W
Rx35	PD14BY2E471J	Insulated carbon film	470 Ω	\pm 5%	1/4W
Rx36	PD14BY2E563J	Insulated carbon film	56k Ω	\pm 5%	1/4W
Rx37	PD14BY2E123J	Insulated carbon film	12k Ω	\pm 5%	1/4W
Rx38, 39	PD14BY2E103J	Insulated carbon film	10k Ω	\pm 5%	1/4W
Rx40	PD14BY2E471J	Insulated carbon film	470 Ω	\pm 5%	1/4W
TRANSISTOR/DIODE/PC BOARD					
Qx1, 2		2SC458LG(C) or (D)			
Qx3		2SA493(GR)			
Qx4		2SC458(C) or (D)			
Qx5		2SC1213A(B) or (C)			
Qx6		2SA673A(B) or (C)			
Qx7, 8		2SC458LG(C) or (D)			
Dx1		MV-13			
—	J25-0562-13	PC board			

SCHEMATIC DIAGRAM

BOTTOM VIEW OF TRANSISTOR

2SC458

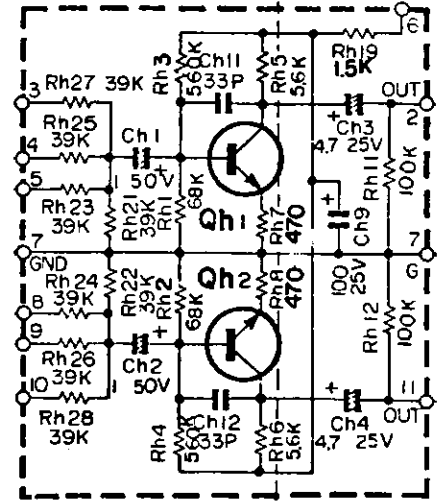
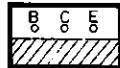

SEALED CIRCUIT ASSEMBLIES PHANTOM VIEWS

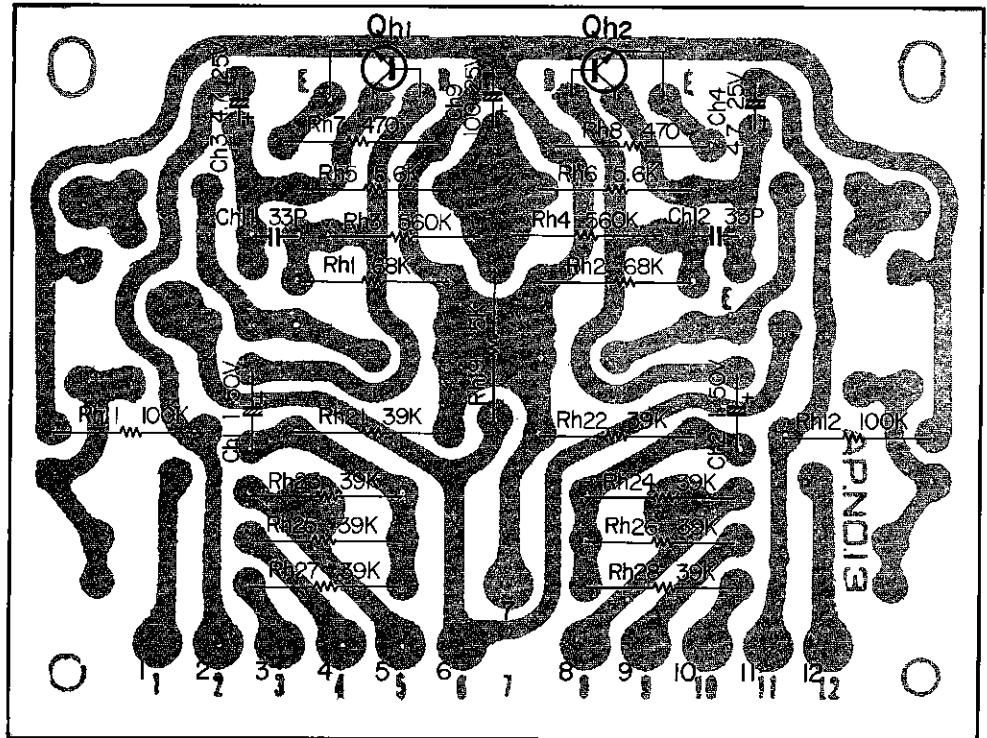

Qh1,2: 2SC458LG (C)

**PARTS DESCRIPTION LIST**

Circuit No.	Parts No.	Description	Remarks
CAPACITOR			
Ch1, 2	CE04W1H010	PC electrolytic 1 μ F 50WV	
Ch3, 4	CE04W1E4R7	PC electrolytic 4.7 μ F 25WV	
Ch9	CE04W1E101	PC electrolytic 100 μ F 25WV	
Ch11, 12	CC94SL1H330K	TC ceramic 33pF \pm 10%	
RESISTOR			
Rh1, 2	PD14BY2E683J	Insulated carbon film 68k Ω \pm 5% 1/4W	
Rh3, 4	PD14BY2E564J	Insulated carbon film 560k Ω \pm 5% 1/4W	
Rh5, 6	PD14BY2E562J	Insulated carbon film 5.6k Ω \pm 5% 1/4W	
Rh7, 8	PD14BY2E471J	Insulated carbon film 470 Ω \pm 5% 1/4W	
Rh11, 12	PD14BY2E104J	Insulated carbon film 100k Ω \pm 5% 1/4W	
Rh19	PD14BY2E152J	Insulated carbon film 1.5k Ω \pm 5% 1/4W	
Rh21~28	PD14BY2E393J	Insulated carbon film 39k Ω \pm 5% 1/4W	
TRANSISTOR/PC BOARD			
Qh1, 2 —	J25-0077-04	2SC458LG(C) PC board	

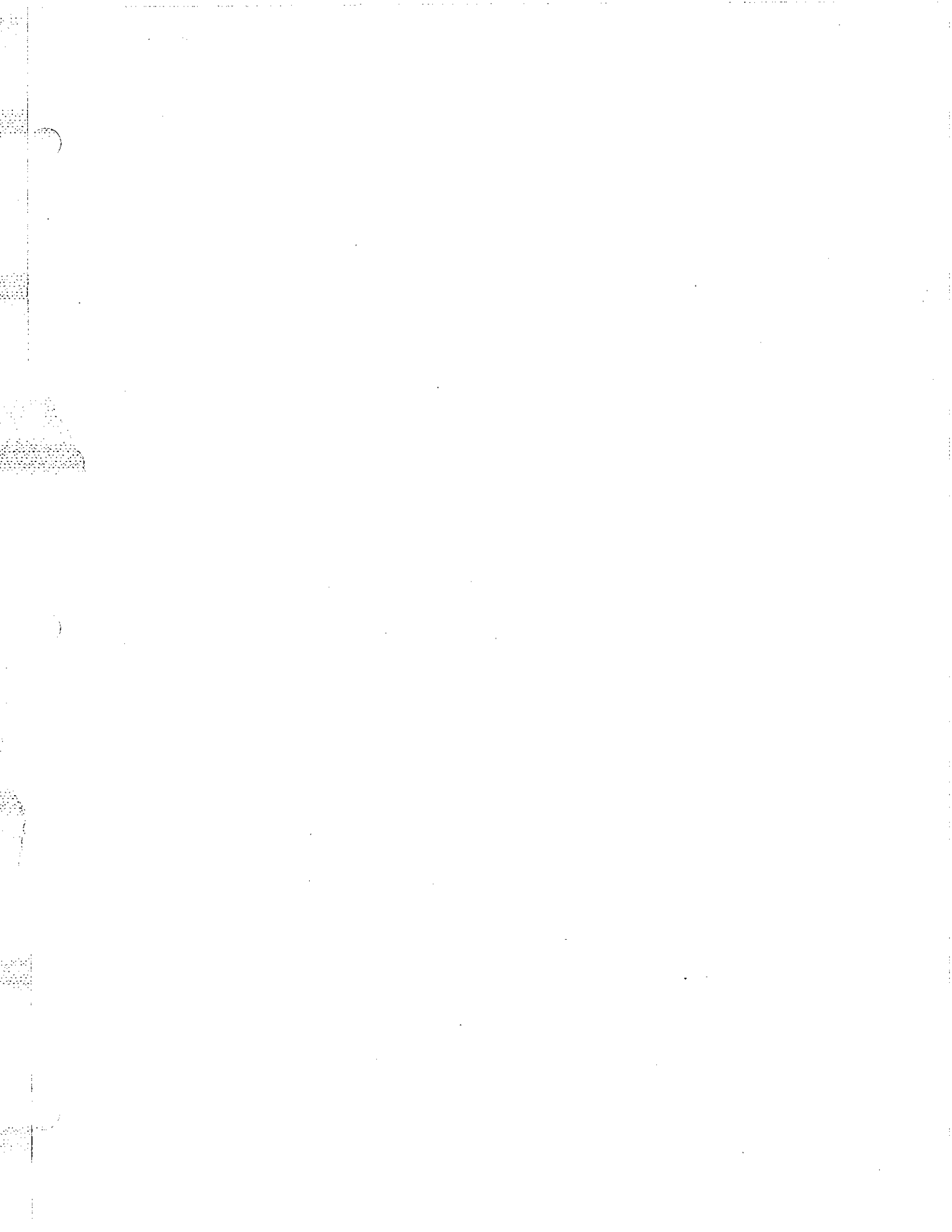



Manufactured by TRIO ELECTRONICS INC., TOKYO, JAPAN.