

STEREO INTEGRATED AMPLIFIER

KA-88

SERVICE MANUAL

KENWOOD

©1989-3 PRINTED IN JAPAN
B51-3867-00(T)2639

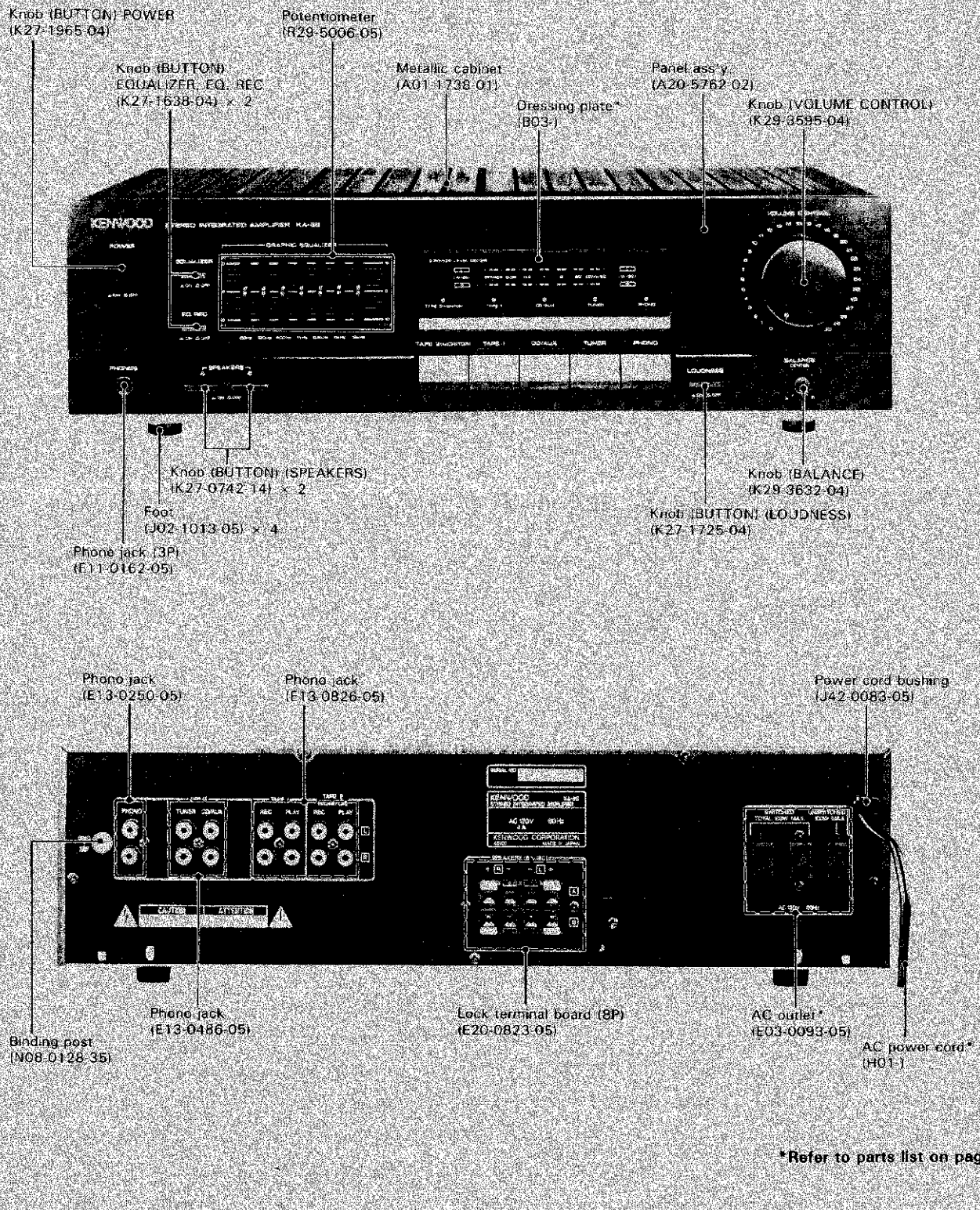

*Refer to parts list on page 20.

KA-88

CONTENTS

CONTROLS AND INDICATORS.....	2	PC BOARD (Component side view).....	7
BLOCK & LEVEL DIAGRAM.....	3	PC BOARD (Foil side view).....	11
CIRCUIT DESCRIPTION.....	4	SCHEMATIC DIAGRAM.....	15
ADJUSTMENT.....	5	EXPLODED VIEW.....	19
REGLAGES.....	5	PARTS LIST.....	20
ABGLEICH.....	5	SPECIFICATIONS.....	Back cover
VOLTAGE TABLES.....	6		

CONTROLS AND INDICATORS

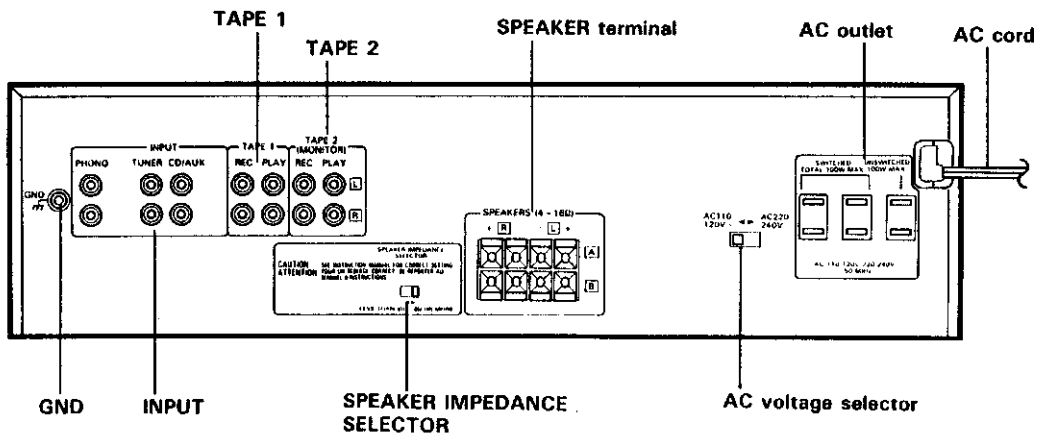
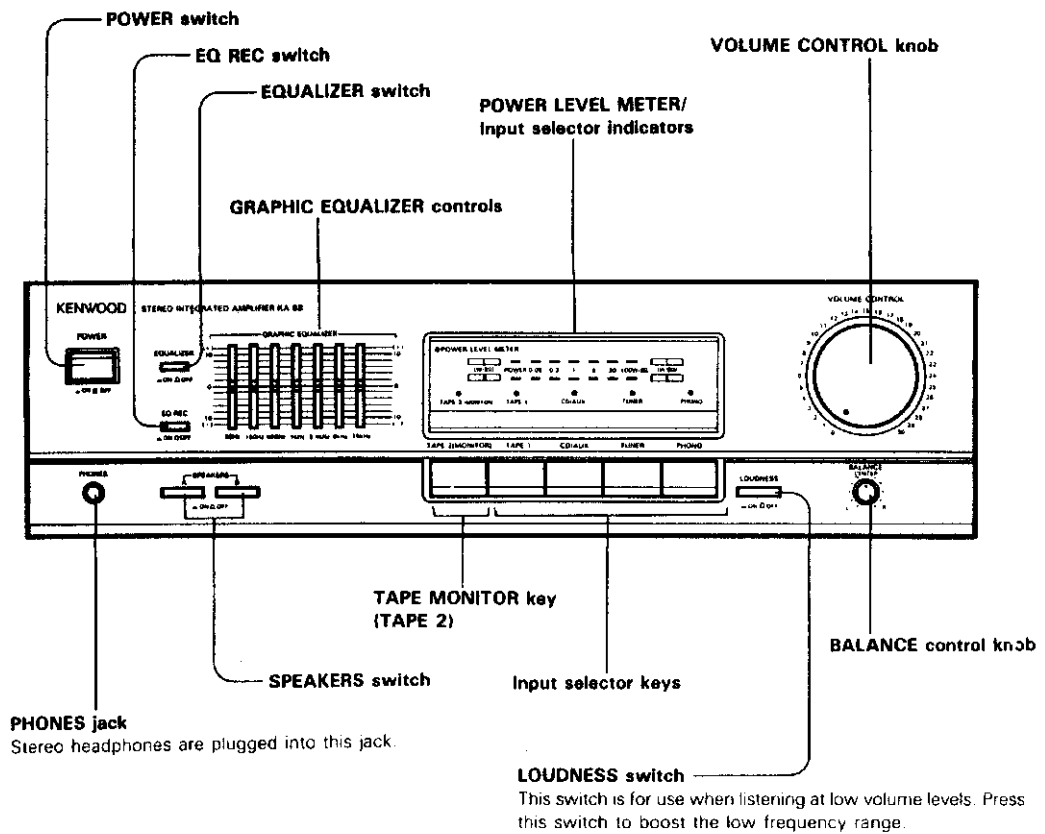

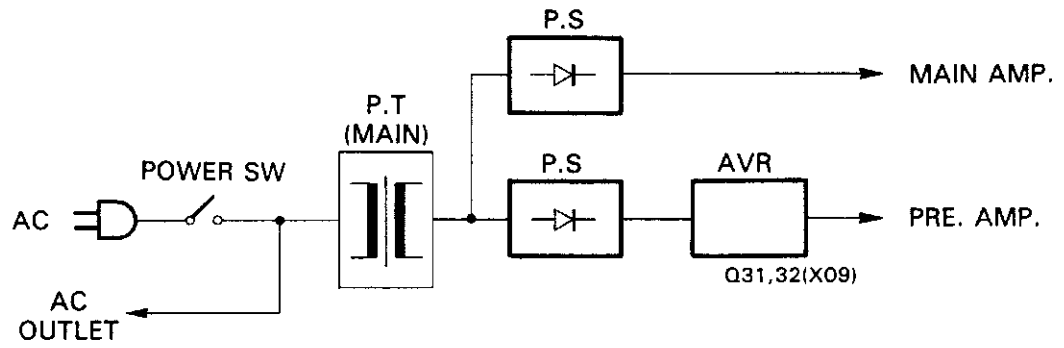
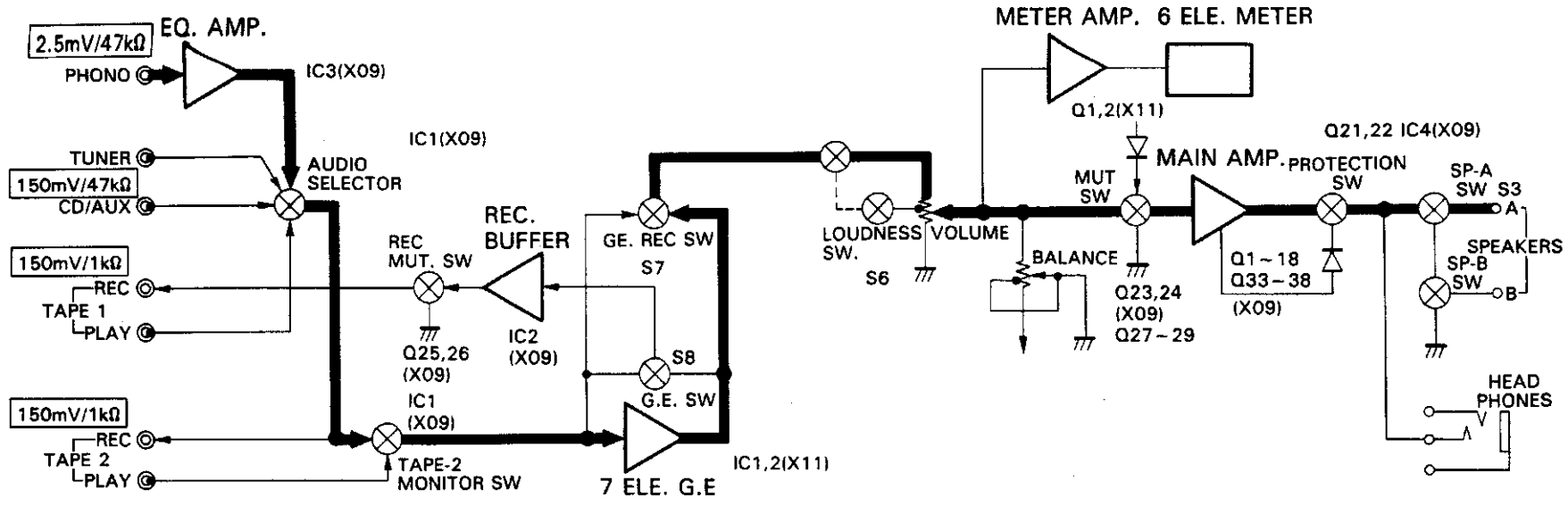

BLOCK & LEVEL DIAGRAM

KA-88

KA-88

CIRCUIT DESCRIPTION

TONE CONTROL UNIT (X11-263X-XX)

Ref.No.	Name	Use and Function	Operation/Condition/Compatibility
IC1, 2	M5229P	7-device graphic equalizer	Here are incorporated seven devices as OP amp type resonance circuits and one device as an output OP amp. This consists of externally connected variable resistor and capacitor setting the resonance frequency and Q. This is the graphic equalizer circuit in which the frequency range between 60 Hz and 15 kHz is divided seven equally for one channel.
IC3	NJM2058D μPC4574C	4-device OP amp	For one channel, OP amp devices are used in series. This is the power level meter circuit in which buffer is placed in the former stage and inversion and compression amps are in the latter stage. Incorporated for two channels.
Q1,2	2SA733(A) 2SA933S	Transistors	Power level meter circuit LED lighting. LED lighting driver, which also provides level compensation.
Q3,4	2SC1740S 2SC945(A)	Transistors	Power level meter circuit LED lighting. Integration driver.
D21,22	HZS2,7N(B2) RD2,7ES(B2)	Zener diodes	Used for the compression amp device in the latter stage in IC3. The audio signal is compressed by making use of zener property when middle or high power is engaged.

AUDIO UNIT (X09-284X-XX)

Ref.No.	Name	Use and Function	Operation/Condition/Compatibility
IC1	LC7818	Input selector	C-MOS ± 13V
IC2	μPC4570C-A	TAPE-1 REC OUT buffer	
IC3	μPC4570C-A	PHONO EQ amp.	
IC4	μPC1237HA	Protection	Reset type
Q1 ~ 4	2SC1845(F,E)	Class A first stage amp	
Q5 ~ 8	2SA992(F,E)	Class A second stage amp	
Q9,10	2SC2632(Q,R,S)	A class amp.	
Q11 ~ 14	2SC2632(Q,R,S)	Third stage amp	
Q15, 16	2SA1124(Q,R,S)	Current mirror	
Q17 ~ 20	2SA1535(Q,R,S) 2SC3944(Q,R,S)	Driver	
Q21,22	2SA733(A) 2SA933S	Over current protection	
Q23 ~ 26	2SC2878(B)	Mutting	HI:ON
Q27 ~ 30	2SA733(A) 2SA933S 2SC1740S 2SC945(A)	Mutting driver	
Q31	2SD882	+ 13 V regulated voltage	
Q32	2SA954(L,K)	- 13 V regulated voltage	
Q39	DTA124EN	For IC1 initialize spec.	Making pin MIN "L" when the + 13 V regulated voltage becomes 10 V.

Device of main body part that does not belong to X09 unit.

Ref.No.	Name	Use and Function	Operation/Condition/Compatibility
Q33 ~ 36	2SB1162 2SB1163 2SD1717 2SD1718	Final stage	
Q37,38	2SC4137(V,W)	Bias transistors	HI:hfe

ADJUSTMENT/REGLAGES/ABGLEICH

ADJUSTMENT

No.	ITEM	INPUT SETTINGS	OUTPUT SETTINGS	AMPLIFIER SETTING	ALIGNMENT POINTS	ALIGN FOR	FIG.
Unless otherwise specified, set the respective switches as follows: POWER: ON SPEAKER: B REC OUT: OFF SELECTOR: PHONO							
1	IDLE CURRENT	-	Connect a DC voltmeter across CP1 (L) CP2 (R) (X09-)	VOLUME: 0	VR1 (L) VR2 (R) (X09-)	18mV	(a)

REGLAGES

N°	ITEM	REGLAGE DE L'ENTREE	REGLAGE DE LA SORTIE	REGLAGE DE L'AMPLIFICATEUR	POINTS DE L'ALIGNMENT	ALIGNER POUR	FIG.
Sauf indication contraire, régler comme suit les commandes respectives: POWER: ON SPEAKER: B REC OUT: OFF SELECTOR: PHONO							
1	COURANT DE POLARISATION	-	Connecter un voltmètre de CC SUR CP1 (G) CP2 (D) (X09-)	VOLUME: 0	VR1 (G) VR2 (D) (X09-)	18mV	(a)

ABGLEICH

NR.	GENGENSTAND	EINGANGS-EINSTELLUNG	AUSANG-EINSTELLUNG	VORSTÄRKER-EINSTELLUNG	ABGLEICHE-PUNKTE	ABGLEICHEN FÜR	ABB.
Wenn nicht anders angegeben, die einzelnen Schalter wie folgt einstellen: POWER: ON SPEAKER: B REC OUT: OFF SELECTOR: PHONO							
1	LEERLAUFSTROM		Einem Gleichspannungsmesser über CP1 (L) CP2 (R) anschießen. (X09-)	VOLUME: 0	VR1 (L) VR2 (R) (X09-)	18mV	(a)

ADJUSTMENT/REGLAGES/ABGLEICH

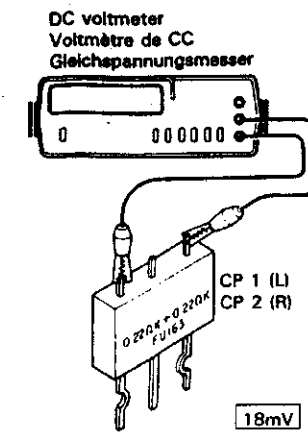

VOLTAGE TABLES

AUDIO UNIT(X09-28XX-XX)

IC1

9	-12V
22	12V

IC2

1,2	0V
4	-12V
6,7	0V
8	12V

IC3

1	0V
4	-12V
7	0V
8	12V

IC4

3	0V
4	2.8V
5	0V
6	0.7V
7	2.2V
8	3.4V

Q1-4

E	-0.6V
C	64.4V
B	0V

Q5-8

E	65V
C	-
B	64.4V

Q9,10

E	-0.6V
C	-
B	0V

Q11,12

E	-64V
C	-0.6V
B	-63.4V

Q13,14

E	-64V
C	-1.2V
B	-63.4V

Q15,16

E	62V
C	1.2V
B	61.4V

Q17,18

E	-0.6V
C	-66.5V
B	-1.2V

Q19,20

E	0.6V
C	66.5V
B	1.2V

Q27

E	12V
C	-
B	-

Q31

E	12.7V
C	30V
B	-

Q32

E	-12.7V
C	-30V
B	-

Q33,34

E	-
C	-66.5V
B	-

Q35,36

E	-
C	66.5V
B	-

Q39

E	12V
C	-
B	-

tone UNIT(X11-263X-XX)

IC1,2

18	12V
20	-12V

IC3

1	0V
4	12V
6-9	12V
11	-12V
14	0V

Q1

E	11V
C	0V
B	11V

Q3

E	0V
C	11V
B	0.4V

PC BOARD (Component side view)

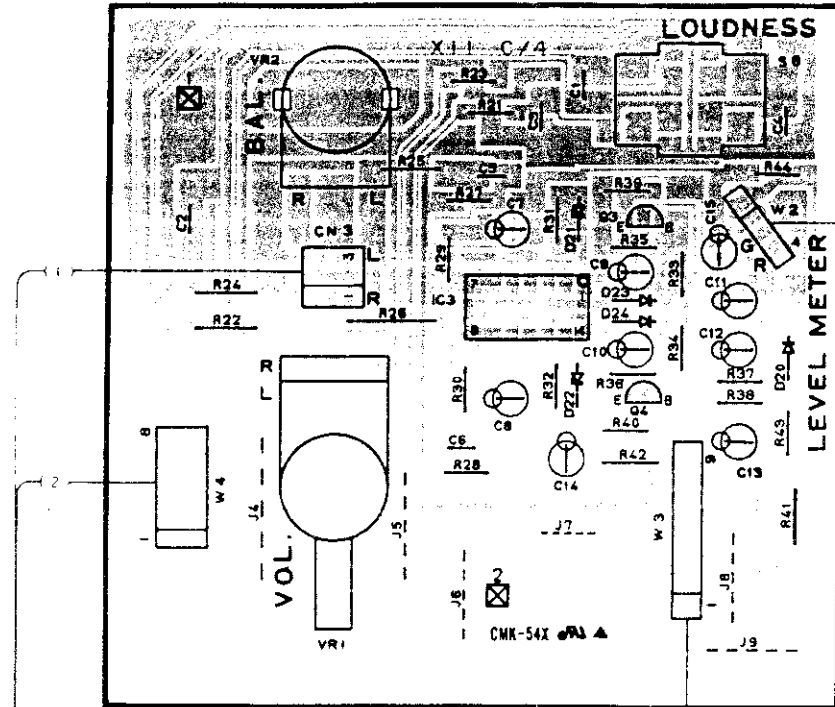

TONE UNIT (X11-) (C/4)

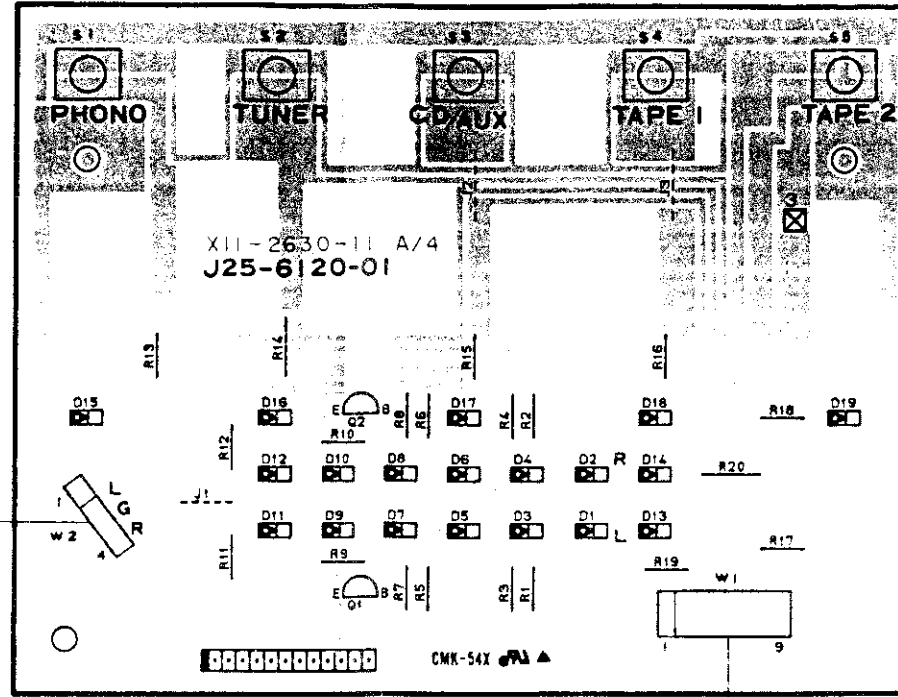

TONE UNIT (X11-263X-XX) (A/4)

FRONT ↑

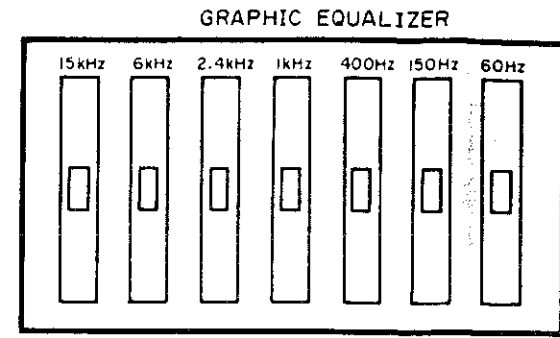

X11-5006-05

TONE UNIT (X11-) (B/4)

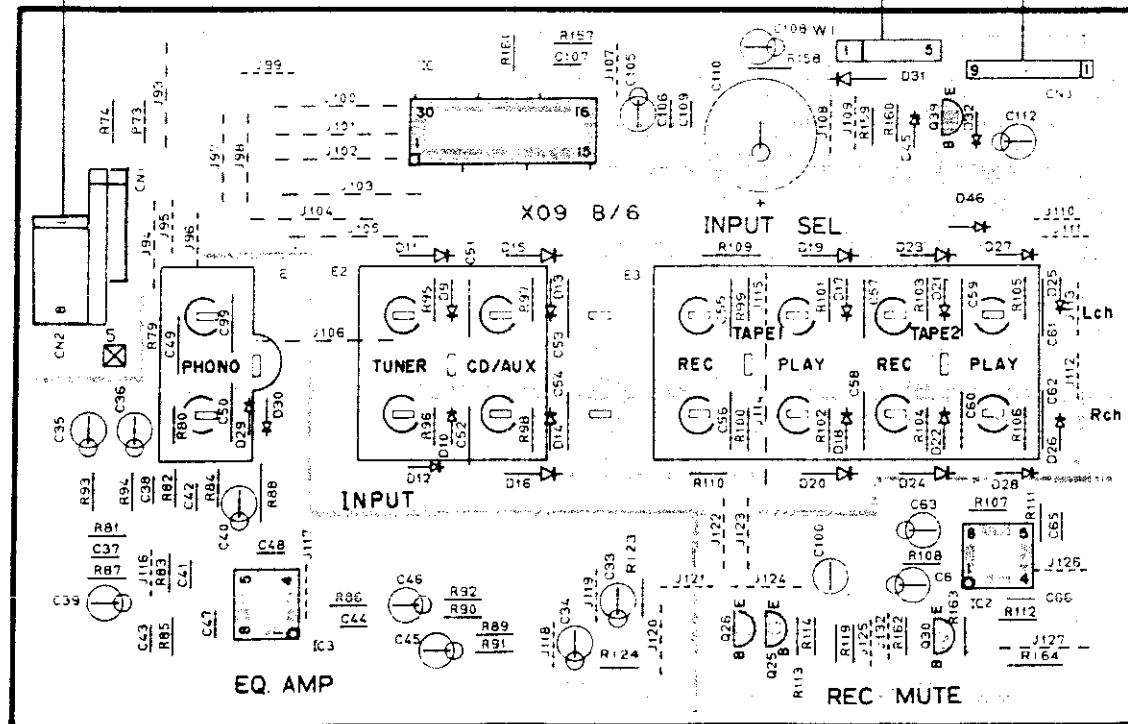
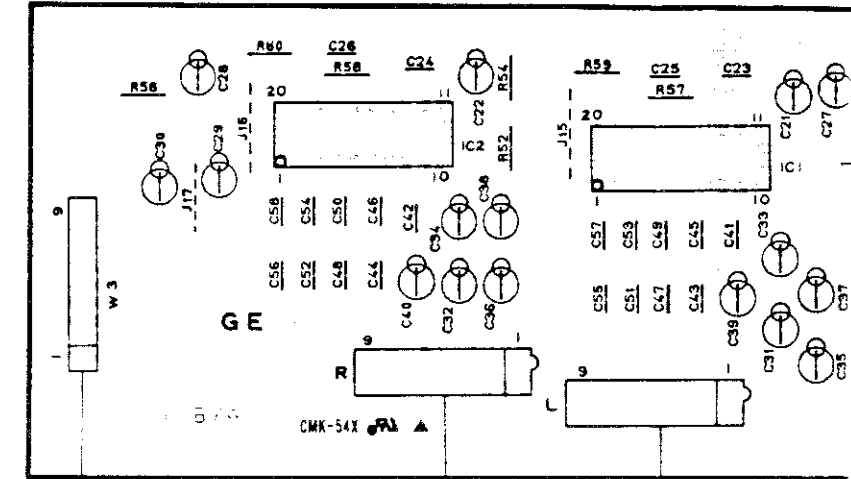

AUDIO UNIT (X09-) (B/6)

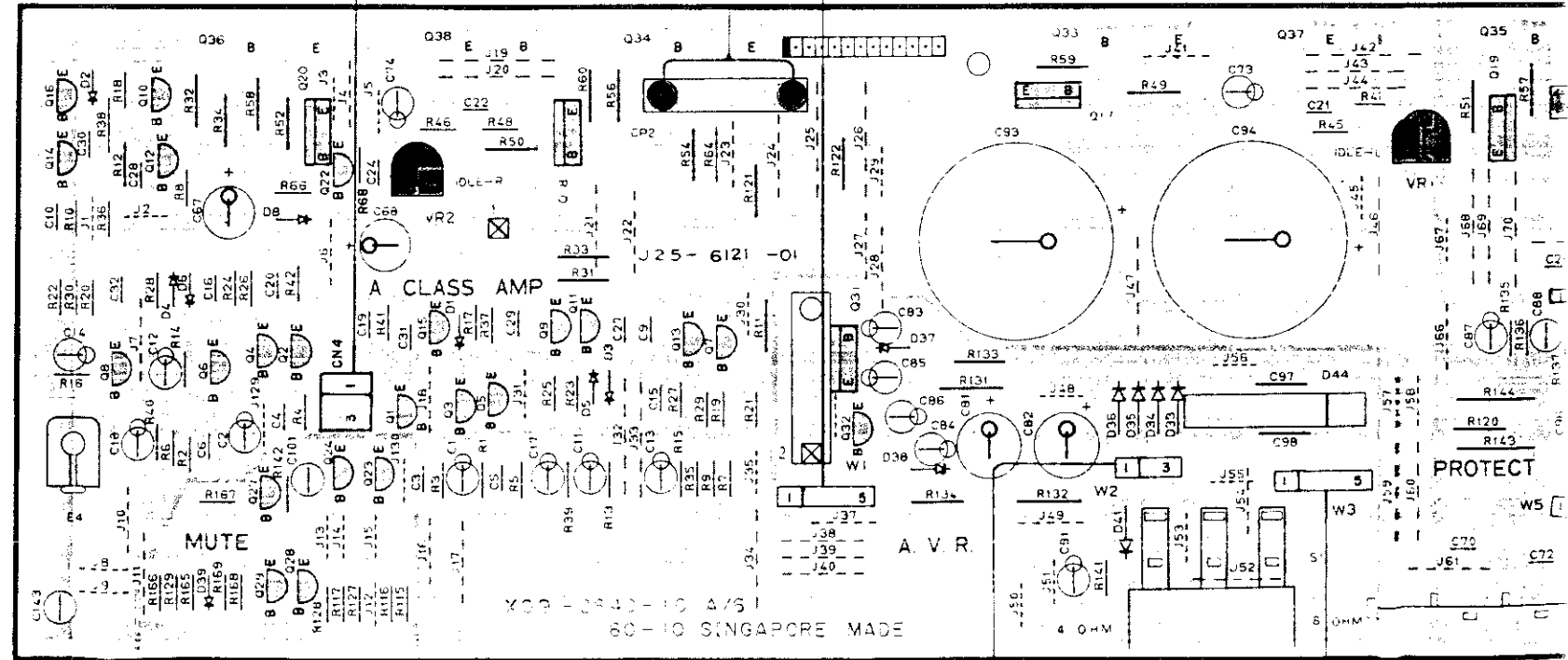

AUDIO UNIT (X09-284X-XX) (A/6)

PROTECT

A.V.R.

4 0 4 M

Rch SPEAKERS

PHIC EQUALIZER

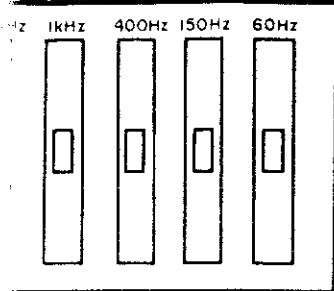

929-5006-05

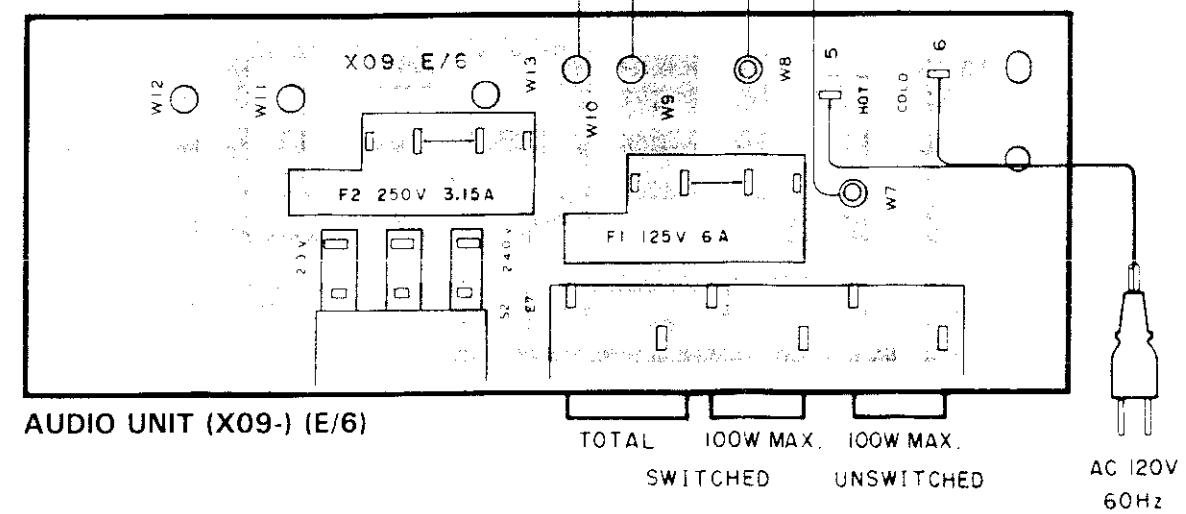
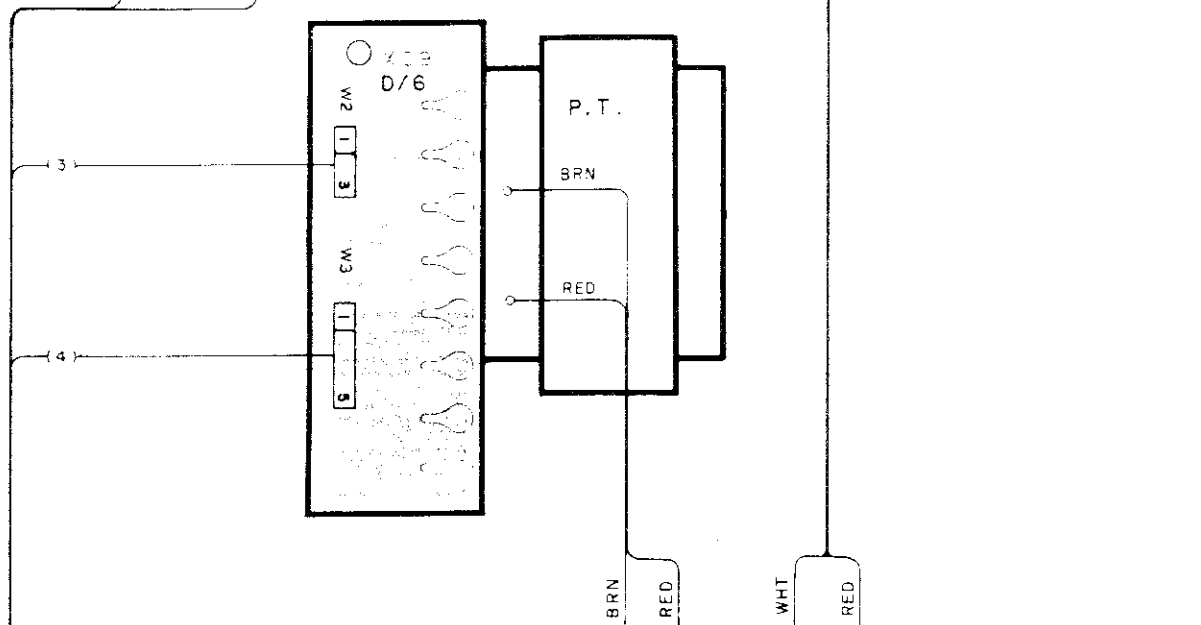
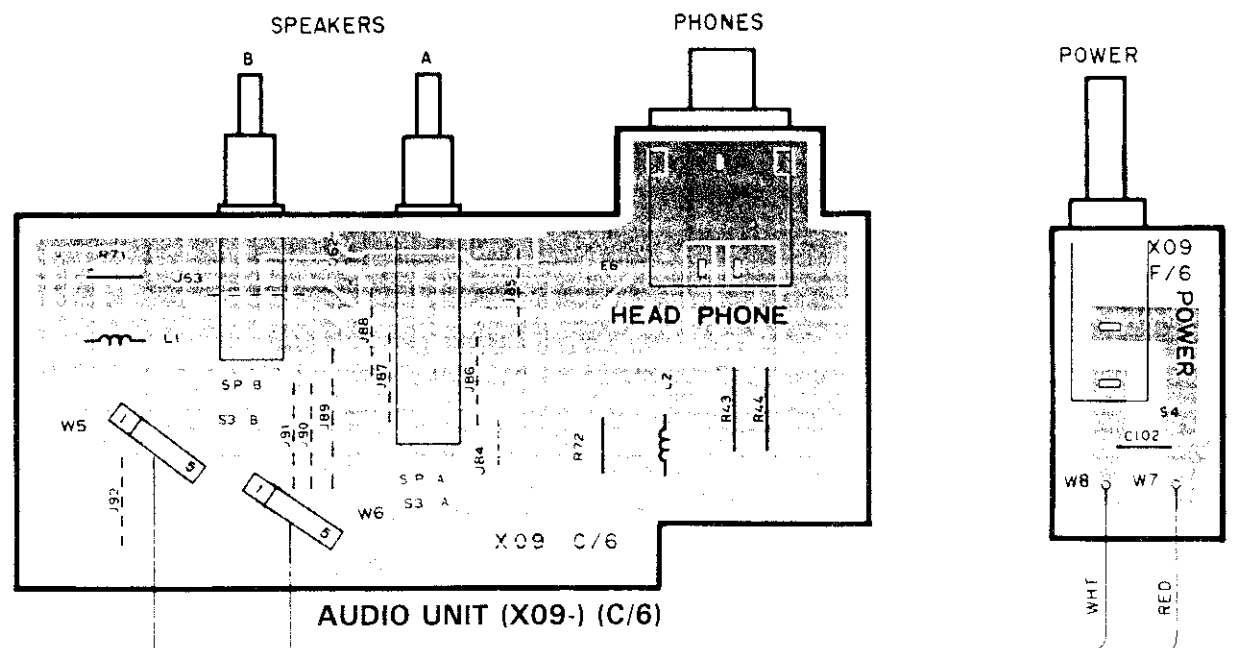
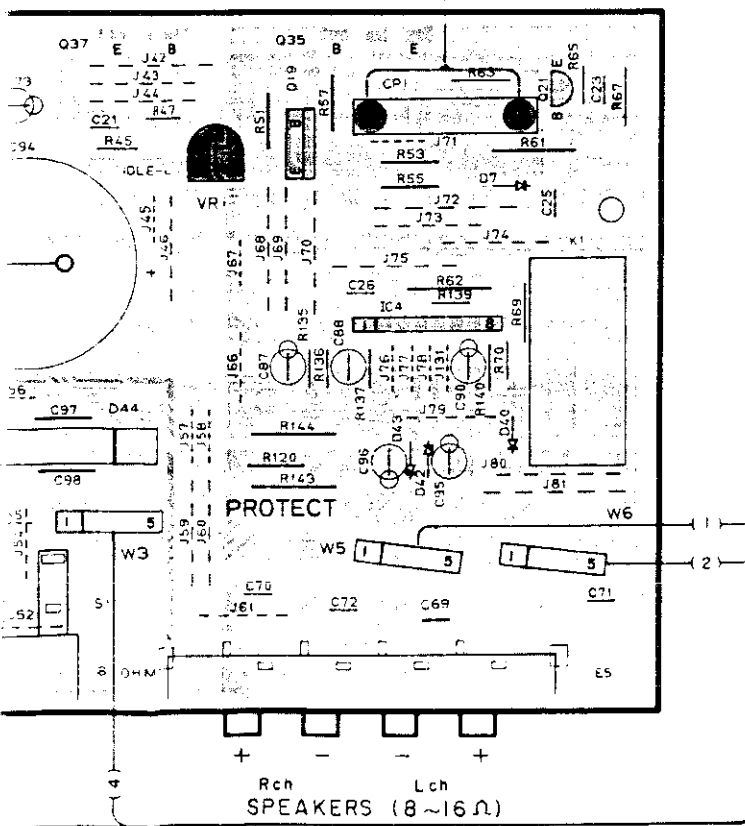
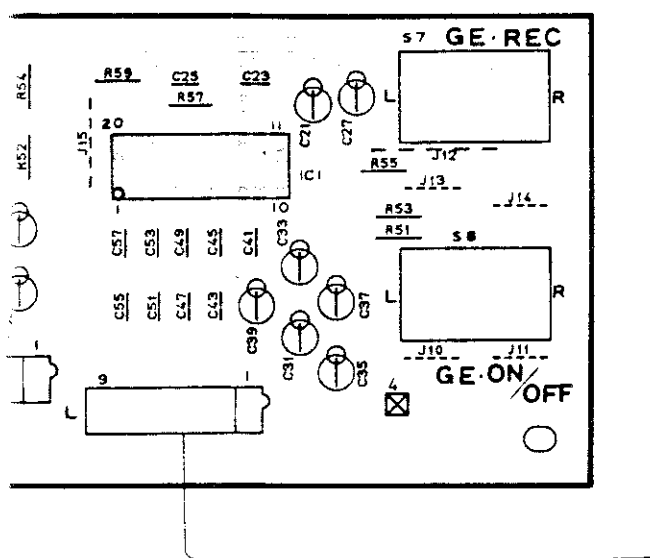

AUDIO UNIT (X09-284X-XX)

Ref. IC	No. Q	Address
	1	6F
	2	6F
	3	6F
	4	6F
	5	6G
	6	6F
	7	6G
	8	6E
	9	5G
	10	5E
	11	5G
	12	5E
	13	6G
	14	5E
	15	5F
	16	5E
	17	5I
	18	5G
	19	5J
	20	5F
	21	5K
	22	5F
	23	6F
	24	6F
	25	6C
	26	6C
	27	6F
	28	6F
	29	6F
	30	6D
	31	6H
	32	6H
	39	5D
1		5B
2		6D
3		6B
4		5J

TONE UNIT (X11-263X-XX)

Ref. IC	No. Q	Address
	1	3E
	2	2E
	3	2C
	4	2C
1		2J
2		2I
3		2B

KA-88(K)

Refer to the schematic diagram for the values of resistors and capacitors.

PC BOARD (Foil side view)

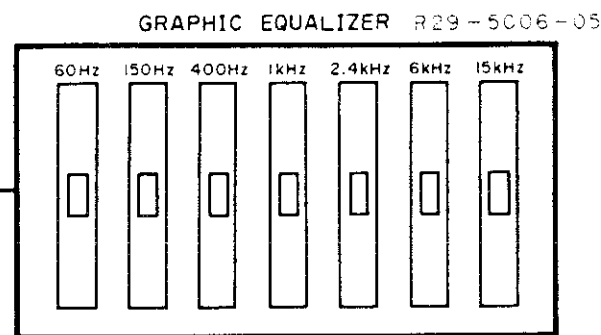
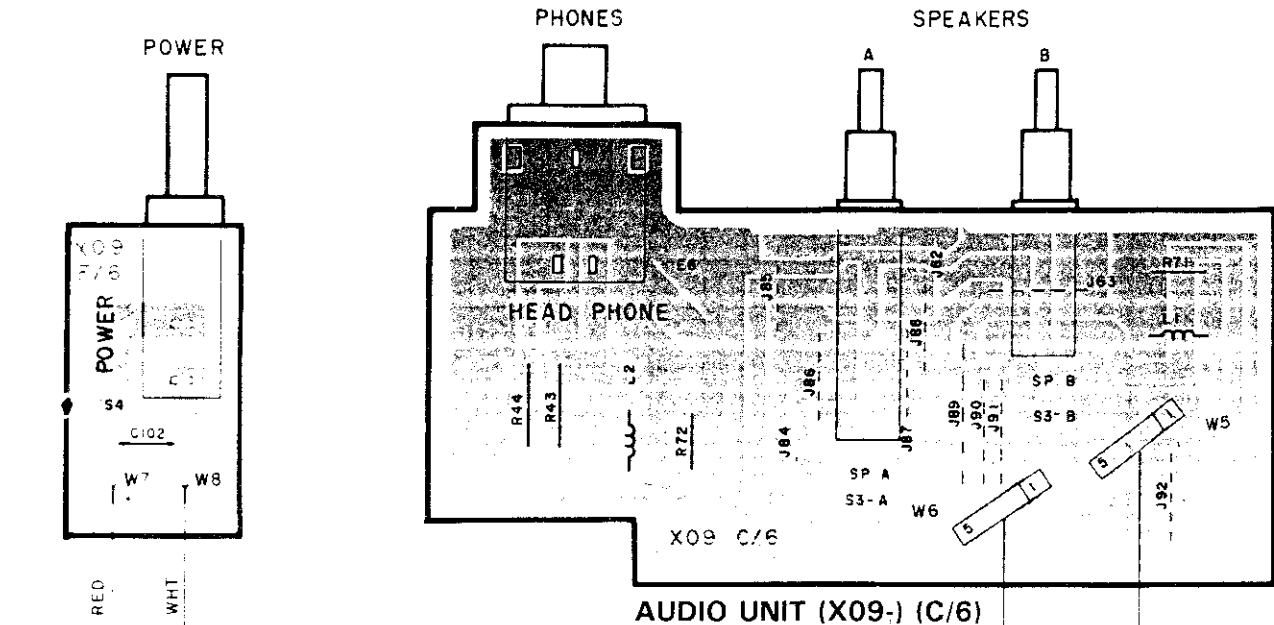

FRONT ↑

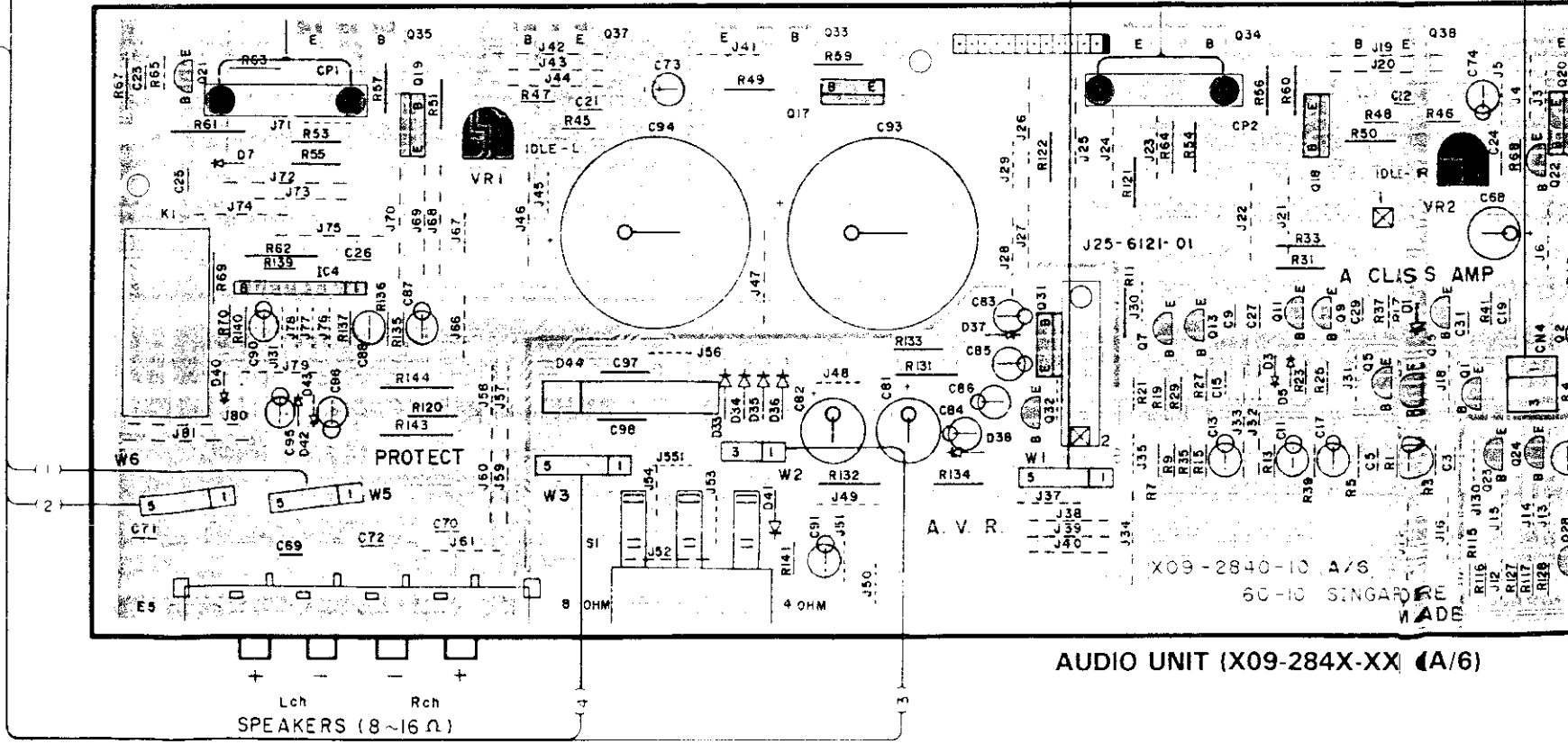
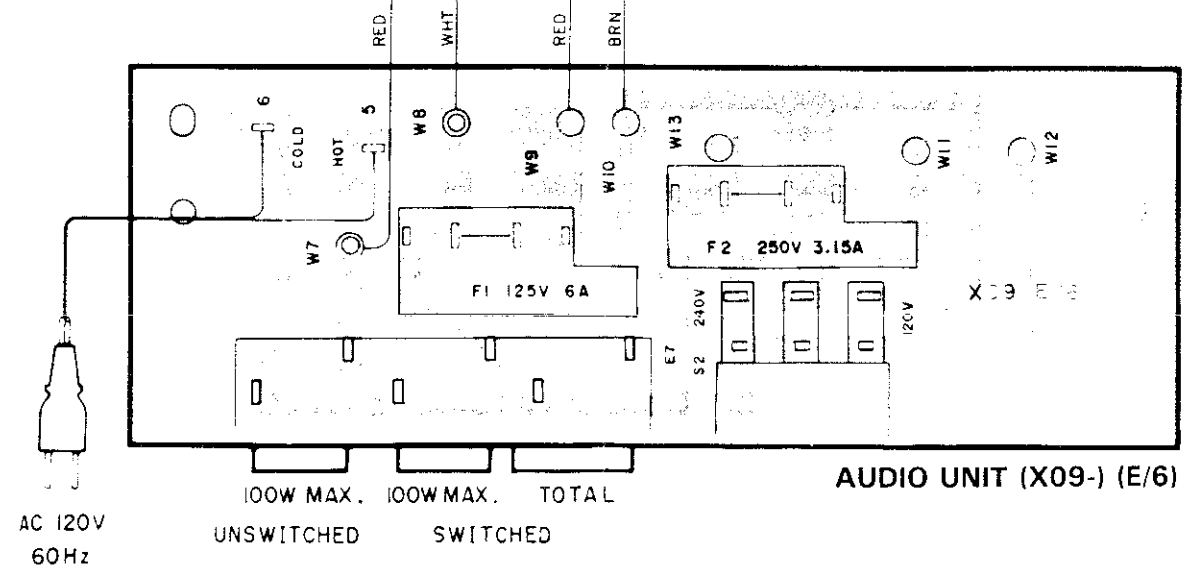
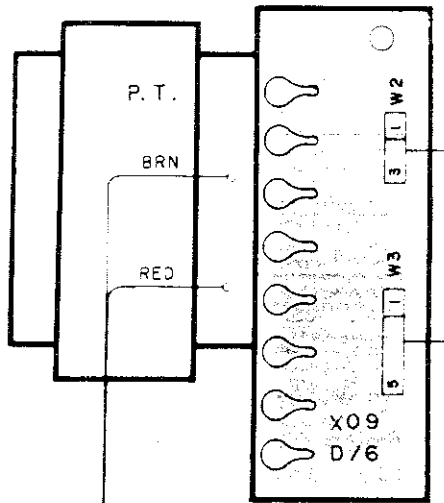
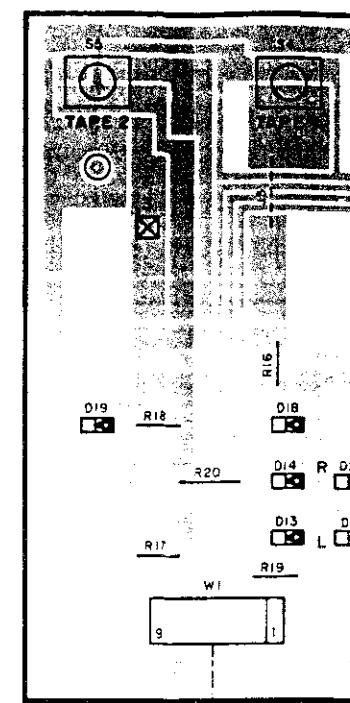
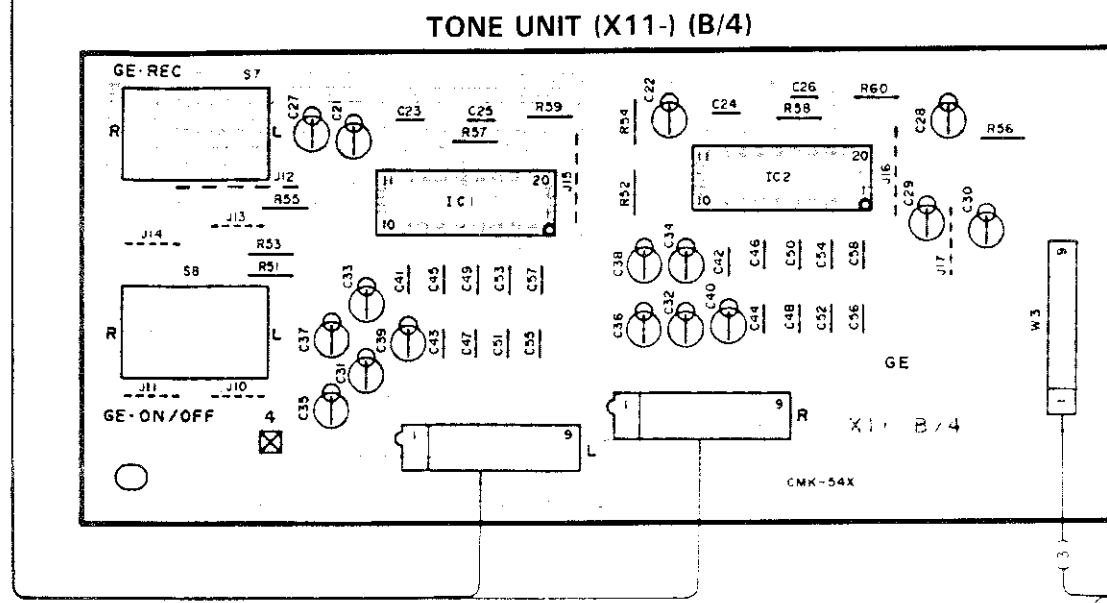

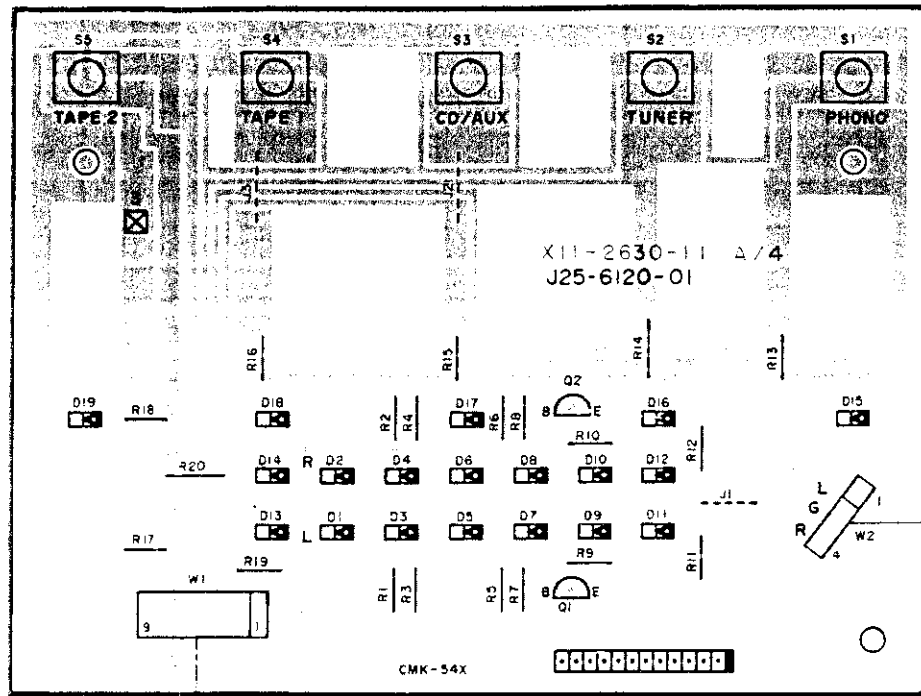

TONE UNIT (X11-263X-XX) (A/4)

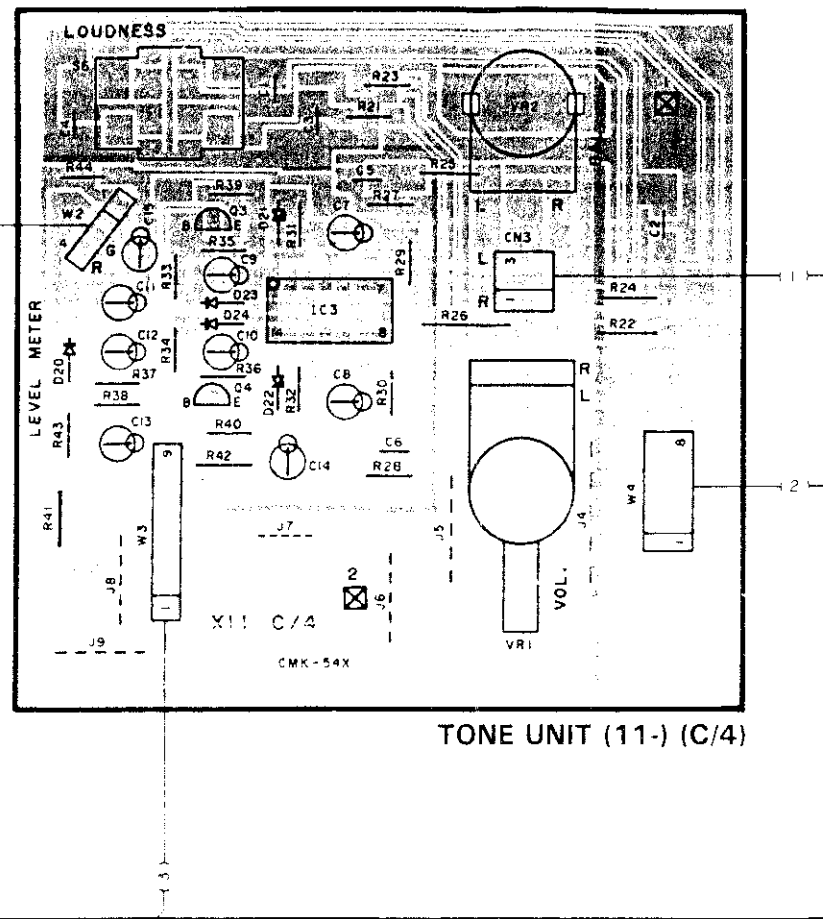

TONE UNIT (11-) (C/4)

AUDIO UNIT (X09-284X-XX)

Ref. No.	IC	Q	Address
1	6AC		6AC
2	6AC		6AC
3	6AC		6AC
4	6AC		6AC
5	6AC		6AC
6	6AD		6AD
7	5AB		5AB
8	6AD		6AD
9	5AC		5AC
10	5AD		5AD
11	5AB		5AB
12	5AD		5AD
13	5AB		5AB
14	5AD		5AD
15	5AC		5AC
16	5AD		5AD
17	5AA		5AA
18	5AB		5AB
19	5Y		5Y
20	5AC		5AC
21	5X		5X
22	5AC		5AC
23	6AC		6AC
24	6AC		6AC
25	6AF		6AF
26	6AF		6AF
27	6AC		6AC
28	6AC		6AC
29	6AC		6AC
30	6AE		6AE
31	6AB		6AB
32	6AA		6AA
39	5AE		5AE
1	5AG		5AG
2	6AE		6AE
3	6AH		6AH
4	5Y		5Y

TONE UNIT (X11-263X-XX)

Ref. No.	IC	Q	Address
1	3AD		3AD
2	2AD		2AD
3	1AF		1AF
4	2AF		2AF
1	2Z		2Z
2	2AA		2AA
3	2AG		2AG

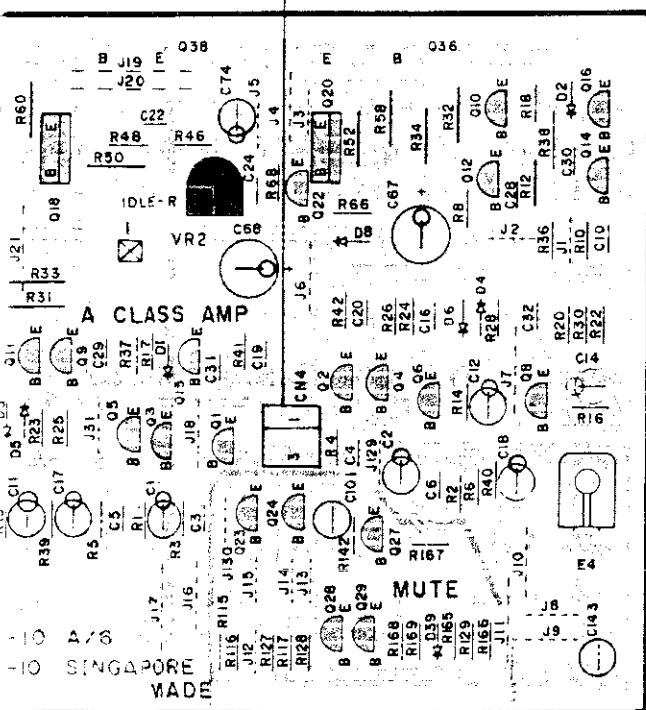

AUDIO UNIT (X09-284X-XX) (A/6)

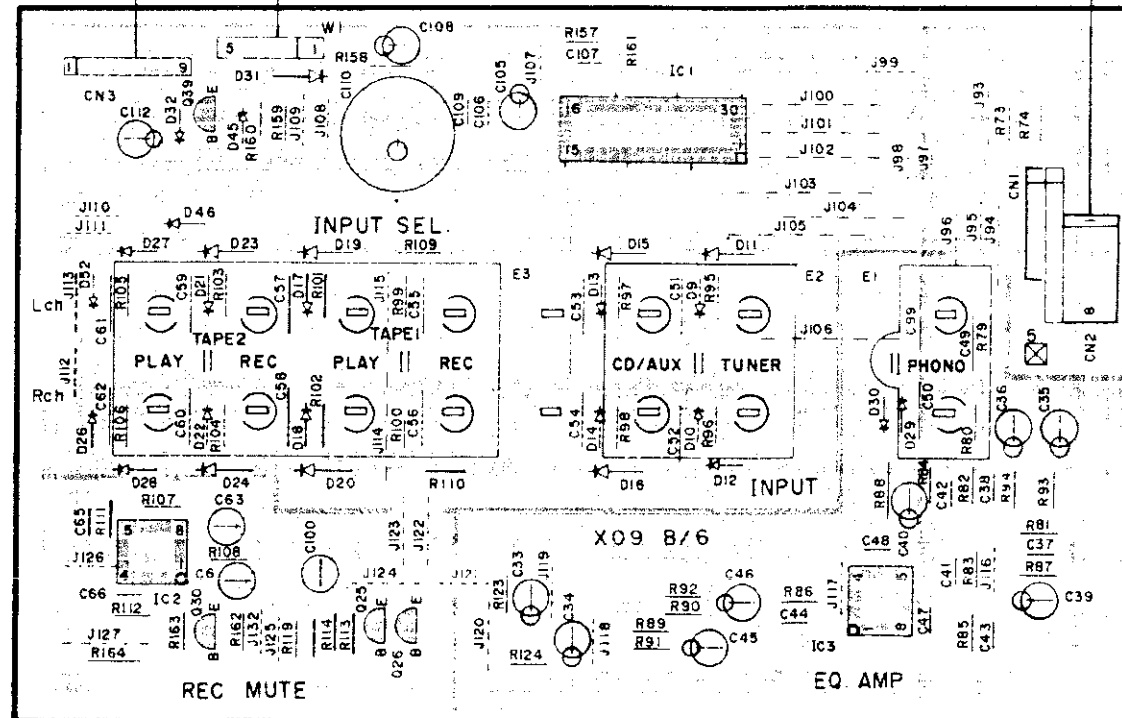

AUDIO UNIT (X09-) (B/6)

KA-88(K)

Refer to the schematic diagram for the values of resistors and capacitors.

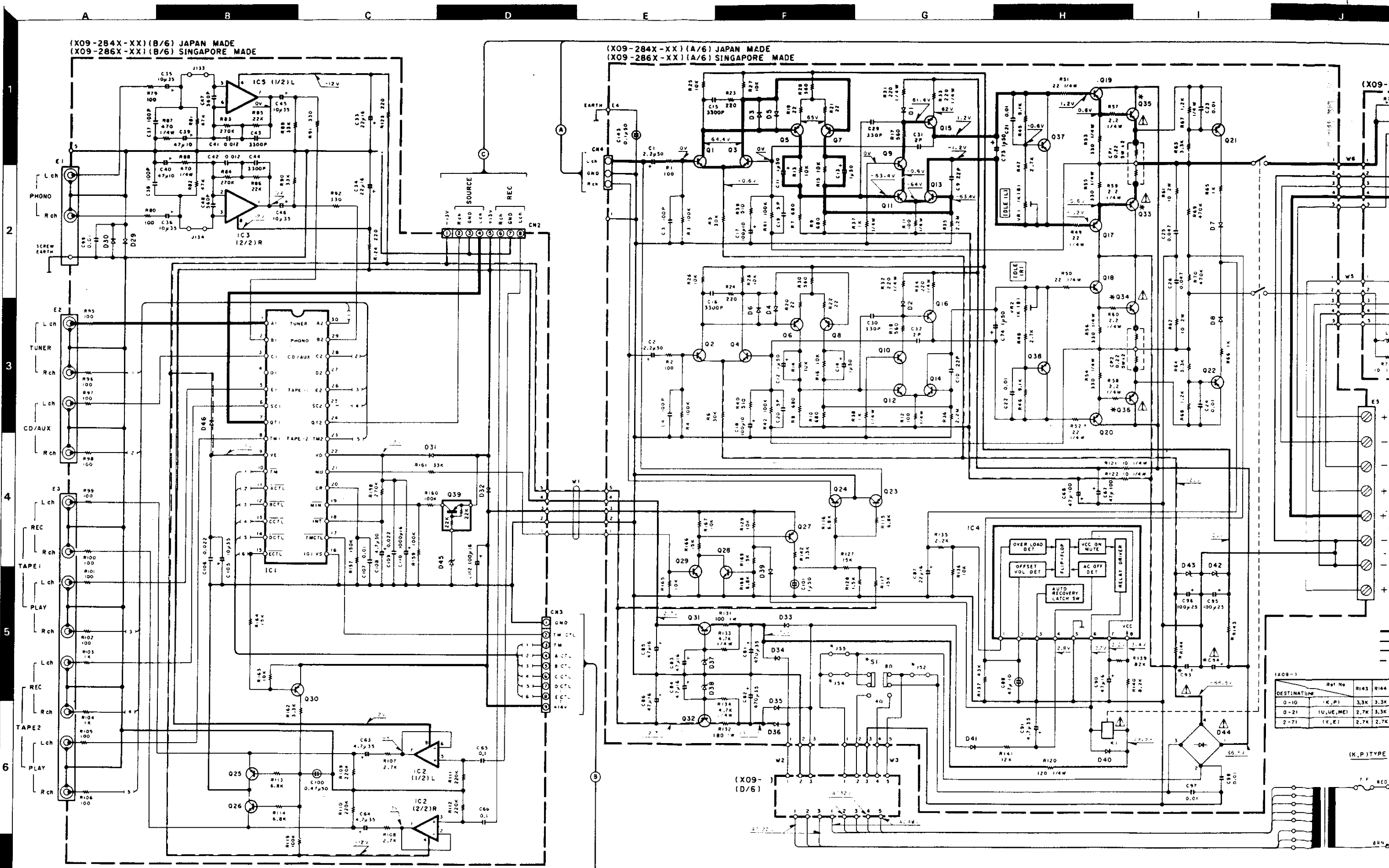

- DTA124EN
- 2SA1124
2SA733(A)
2SA954
2SA992
2SC1845
2SC2632
2SC2878
2SC945(A)
- 2SD882
- 2SA933S
2SC1740S
- 2SC4137
- 2SB1182
2SB1163
2SD1717
2SD1718
- 2SA1535
2SC3944
- NJM2058D
- µPC4574C
- M5229P
- µPC4570C-A
- µPC1237HA
- LC7818

DESTINATION	Ref No	R143	R144
0-10	(K,P)	3.3K	3.3K
0-21	(U,VE,ME)	2.7K	3.3K
2-71	(X,E)	2.7K	2.7K

(K,P) TYPE

DC voltage
voltage
between

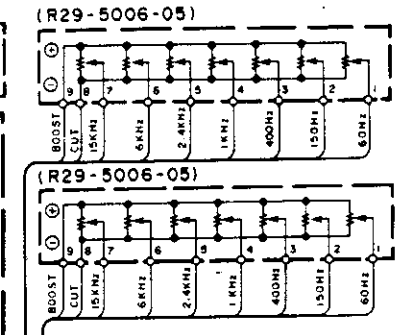
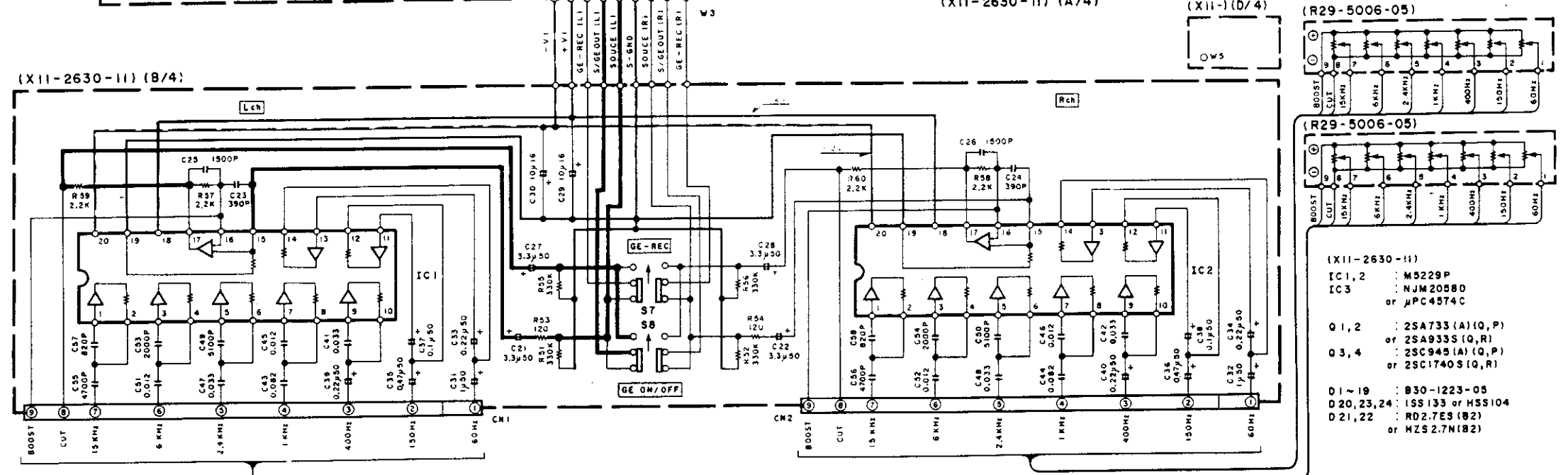
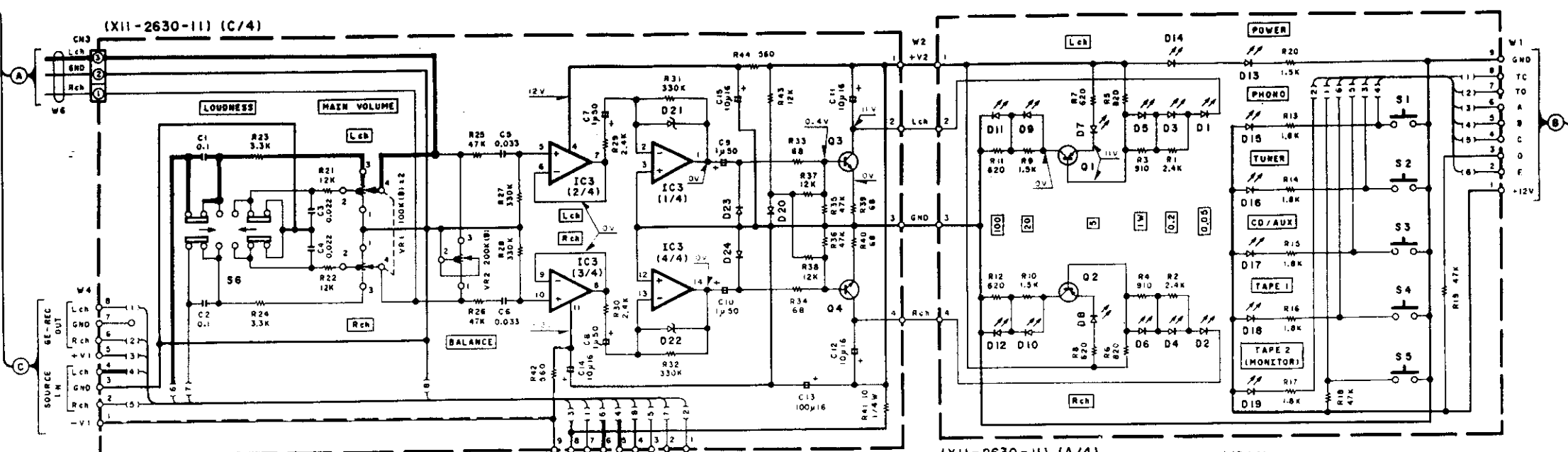
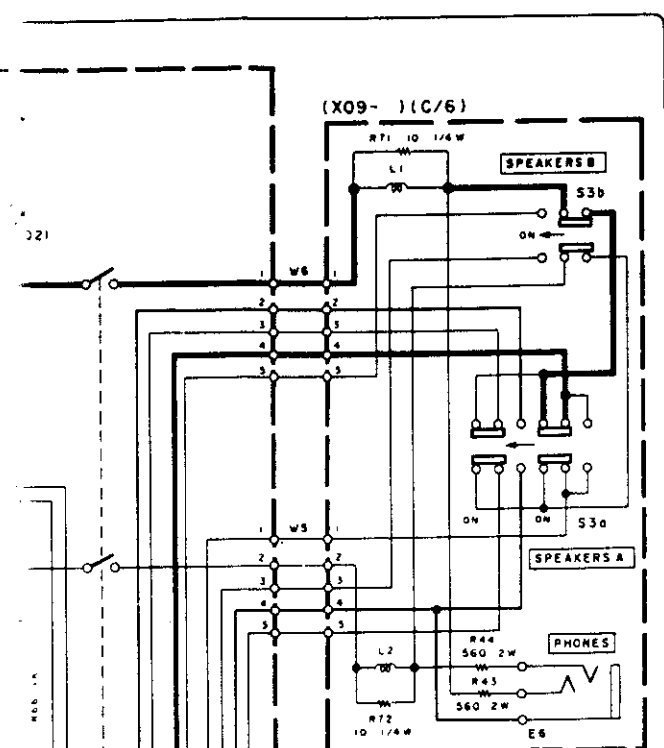

- (X11-2630-II)
- IC1, 2 : M5229P
 - IC3 : NJM2058D or μ PC4574C
 - Q1, 2 : 2SA733 (A) (Q, P) or 2SA935S (Q, R)
 - Q3, 4 : 2SC945 (A) (Q, P) or 2SC1740S (Q, R)
 - D1 ~ 19 : B30-1223-05
 - D20, 23, 24 : 1SS133 or HSS104
 - D21, 22 : RD2.7E3 (B2) or HZS 2.7N (B2)

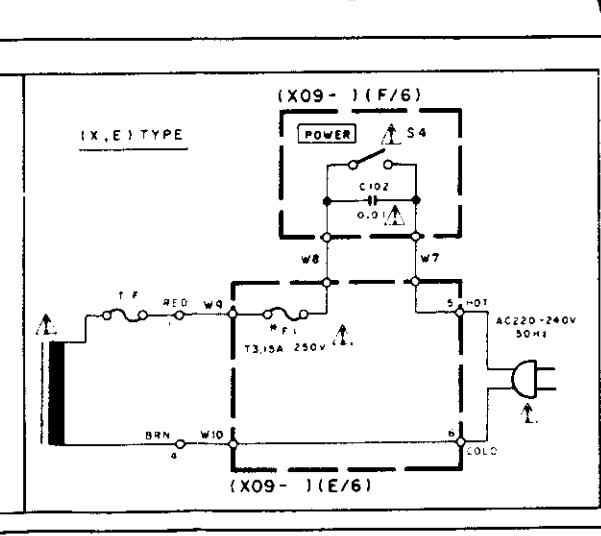
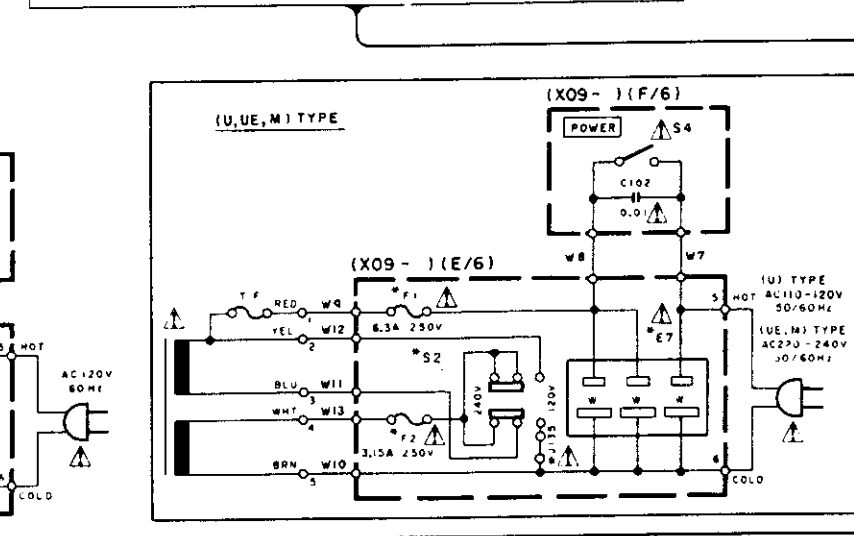
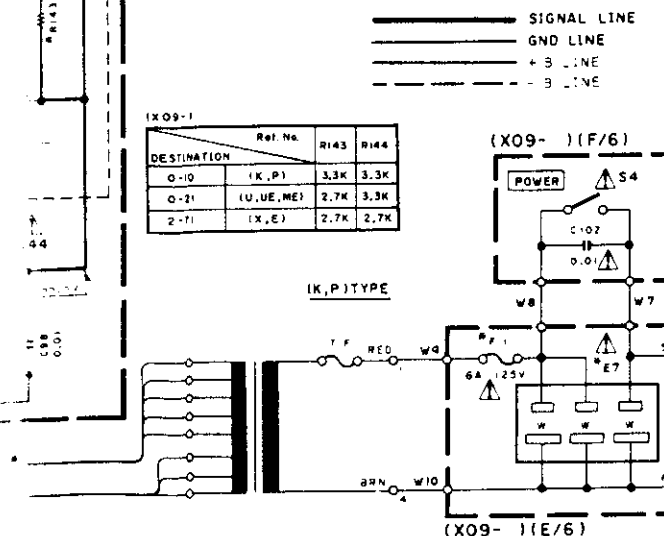

- (X09-284X-XX) (X09-286X-XX)
- IC1 : LC7818
 - IC2, 3 : μ PC4570C-A
 - IC4 : μ PC1237HA
 - Q1 ~ 4 : 2SC1845 (F, E)
 - Q5 ~ 8 : 2SA982 (F, E)
 - Q9 ~ 14 : 2SC2632 (Q, R, S)
 - Q15, 16 : 2SA1124 (Q, R, S)
 - Q17, 18 : 2SA1555 (Q, R, S)
 - Q19, 20 : 2SC3944 (Q, R, S)
 - Q21, 22, 27, 30 : 2SA733 (A) (Q, P) or 2SA935S (Q, R)
 - Q23 ~ 26 : 2SC2878 (B)
 - Q28, 29 : 2SC945 (A) (Q, P) or 2SC1740S (Q, R)
 - Q31 : 2SD882
 - Q32 : 2SA954 (L, K)
 - * Q33, 34
 - * Q35, 36
 - Q37, 38 : 2SC4137 (V, W)
 - Q39 : OTA124 EN
 - D1 ~ 8, 29 ~ 32, 39, 40, 46 : 1SS133 or HSS104
 - D33 ~ 36, 41 : S5568 B
 - D37, 38 : RD13ES (B2) or HZS13N (B2)
 - D42, 43 : RD20ES (B) or HZS20N (B)
 - D44 : RBV-602LFA
 - D45 : RD10ES (B) or HZS10N (B)

(X09-1)

DESTINATION	Ref. No.	C83, 94	Q33, 34	Q35, 36	S1	S2	E7	F1	F2	S4	J32	J33
0-10	(K, P)	8200 μ 71	2581163	2501718	NO	NO	YES	6A 125V	NO	NO	YES	NO
0-21	(U, UE, M)	8200 μ 71	2581163	2501718	YES	YES	YES	6.3A 250V	YES	YES	NO	YES
2-71	(X, E)	7800 μ 71	2581162	2501717	YES	NO	NO	13.15A 250V	NO	YES	NO	NO

DC voltages are as measured with a high impedance voltmeter. Values may vary slightly due to variations between individual instruments or and units.

CAUTION: For continued safety, replace safety critical components only with manufacturer's recommended parts (refer to parts list). Δ indicates safety critical components. To reduce the risk of electric shock, leakage-current or resistance

measurements shall be carried out (exposed parts are acceptably insulated from the supply circuit) before the appliance is returned to the customer.



KA-88 KA-88

EXPLODED VIEW

PARTS LIST

* New Parts

Parts without Parts No. are not supplied.

Les articles non mentionnés dans le Parts No. ne sont pas fournis.

Teile ohne Parts No. werden nicht geliefert.

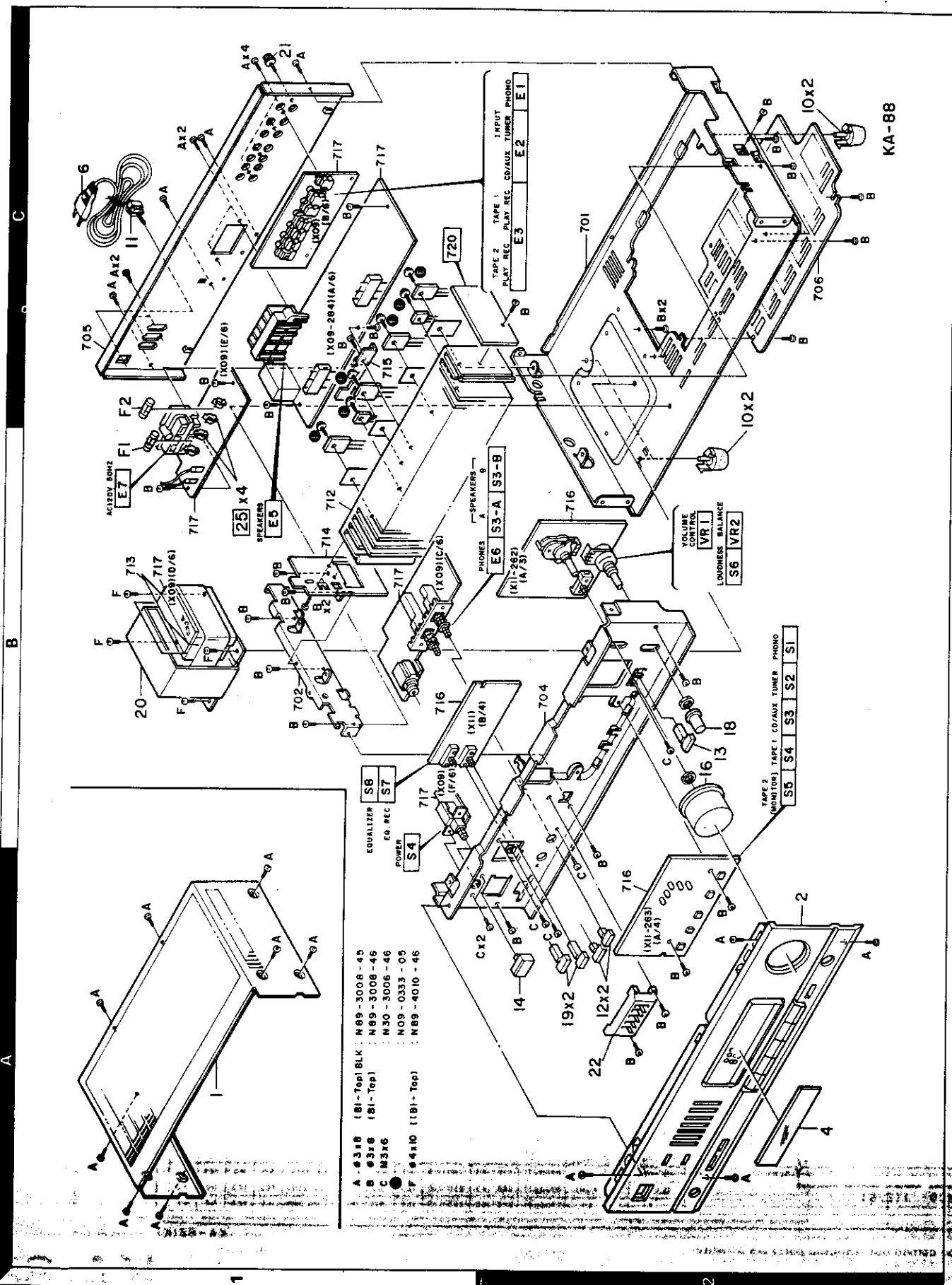

Ref. No.	Address	New Parts	Parts No.	Description	Destination	Remarks
参照番号	位置	新	部品番号	部品名 / 規格	仕向	備考
KA-88						
1	1A		A01-1738-01	METALLIC CABINET		
2	2A	*	A20-5762-02	PANEL ASSY		
4	2A	*	B03-2524-04	DRESSING PLATE		J
4	2A	*	B03-2536-04	DRESSING PLATE		S
			B46-0092-03	WARRANTY CARD	K	
			B46-0094-03	WARRANTY CARD	UE	
			B46-0095-03	WARRANTY CARD	UE	
			B46-0096-13	WARRANTY CARD	X	
			B46-0121-03	WARRANTY CARD	P	
			B46-0122-13	WARRANTY CARD	E	
		*	B50-9470-00	INSTRUCTION MANUAL		J
		*	B50-9471-00	INSTRUCTION MANUAL	PME	J
		*	B50-9473-00	INSTRUCTION MANUAL		J
		*	B50-9475-00	INSTRUCTION MANUAL	M	J
		*	B50-9647-00	INSTRUCTION MANUAL		S
		*	B50-9648-00	INSTRUCTION MANUAL	PME	S
		*	B50-9650-00	INSTRUCTION MANUAL	M	S
		*	B50-9652-00	INSTRUCTION MANUAL		S
			B58-0223-04	CAUTION CARD (PRE-SET 120V)	E	
			B58-0513-04	CAUTION CARD (PRESET 220-240)	UE	
			B58-0803-13	CAUTION CARD	E	
△	6	1C	E30-0459-05	AC POWER CORD	E	
△	6	1C	E30-0812-05	AC POWER CORD	UEEM	
△	6	1C	E30-0974-05	AC POWER CORD	KP	J
△	6	1C	E30-1341-05	AC POWER CORD	X	
△	6	1C	E30-2209-05	AC POWER CORD	KP	S
△	F1	1B	F05-3121-05	FUSE (SEMKO) (250V T3.15A)	XE	
△	F1	1B	F05-3123-05	FUSE (SEMKO) (250V 3.15A)	UEEM	
△	F1	1B	F05-6029-05	FUSE (UL)	KP	
△	F2	1C	F05-6324-05	FUSE (250V 6.3A)	UEEM	
		*	H01-8442-04	ITEM CARTON CASE		J
		*	H01-8515-04	ITEM CARTON CASE		S
		*	H10-3845-02	POLYSTYRENE FOAMED FIXTURE		J
		*	H10-3846-02	POLYSTYRENE FOAMED FIXTURE		J
		*	H10-3847-02	POLYSTYRENE FOAMED FIXTURE		S
			H10-3848-02	POLYSTYRENE FOAMED FIXTURE		S
			H25-0223-04	PROTECTION BAG (750X350X0.03)		
			H25-0232-04	PROTECTION BAG (235X350X0.03)		
△	10	2C	J02-1013-05	FOOT		
	11	1C	J42-0083-05	POWER CORD BUSHING		
			J61-0307-05	WIRE BAND		
	12	2A	K27-0742-14	KNOB (BUTTON) SPEAKERS		
	13	2B	K27-1725-04	KNOB (BUTTON) LOUDNESS		
	14	2A	K27-1965-04	KNOB (BUTTON) POWER		
	16	2B	K29-3595-04	KNOB VOLUME CONTROL		
	18	2B	K29-3632-04	KNOB BARANCE		
	19	2A	K27-1638-04	KNOB (BUTTON) EQUALIZER, EQ, REC		
△	20	1B	L01-7621-05	POWER TRANSFORMER	KP	
△	20	1B	L01-7622-05	POWER TRANSFORMER	X	
△	20	1B	L01-7625-05	POWER TRANSFORMER	UEEM	
△	20	1B	L01-7627-15	POWER TRANSFORMER	E	

E: Scandinavia & Europe K: USA P: Canada

U: PX(Far East, Hawaii) T: England M: Other Areas

UE: AAFES(Europe) X: Australia

J: Japan made

S: Singapore made

△ indicates safety critical components.

Parts with the exploded numbers larger than 700 are not supplied.

PARTS LIST

× New Parts

Parts without Parts No. are not supplied.

Les articles non mentionnés dans le Parts No. ne sont pas fournis.

Telle ohne Parts No. werden nicht geliefert.

Ref. No. 参照番号	Address 位置	New Parts 新	Parts No. 部品番号	Description 部品名 / 規格	Desti- nation 仕 向	Re- marks 備考
C88			C90-1334-05	NP-ELEC 47UF 10WV		
C90			CE04KW1C470M	ELECTR0 47UF 16WV		J
C90			CE04LW1C470M	ELECTR0 47UF 16WV		S
C91			CE04KW1V4R7M	ELECTR0 4.7UF 35WV		J
C91			CE04LW1V4R7M	ELECTR0 4.7UF 35WV		S
E93 ,94		*	C90-1760-05	ALUMINIUM ELECTROLYTIC C.	KPUJUEM	
E93 ,94		*	C90-1761-05	ALUMINIUM ELECTROLYTIC C.	XE	
C95 ,96			CE04KW1E101M	ELECTR0 100UF 25WV		J
C95 ,96			CE04LW1E101M	ELECTR0 100UF 25WV		S
C97 ,98			CK45FE2H103P	CERAMIC 0.010UF P		
C99			C91-0769-05	CERAMIC 0.01UF M		
C100			C90-1331-05	NP-ELEC 0.47UF 50WV		
C101			C90-1349-05	NP-ELEC 1UF 50WV		
C102			C91-0023-05	CERAMIC 0.01UF AC250V	UUEM	
C102			C91-0647-05	CERAMIC 0.01UF P	XE	
C102			C91-0971-05	FILM 0.01UF 250WV	KP	
C105			CE04KW1V100M	ELECTR0 10UF 35WV		J
C105			CE04LW1V100M	ELECTR0 10UF 35WV		S
C106			CK45FF1H223Z	CERAMIC 0.022UF Z		
C107			CF92FV1H103J	MF 0.010UF J		
C108			CE04KW1V4R7M	ELECTR0 4.7UF 35WV		J
C108			CE04LW1V4R7M	ELECTR0 4.7UF 35WV		S
C109			CK45FF1H223Z	CERAMIC 0.022UF Z		
C110			C90-1256-05	ELECTR0 1000UF 16WV		J
C112			CE04KW1C101M	ELECTR0 100UF 16WV		S
C113			C90-1455-05	NP-ELEC 0.1UF 50WV		
E1		*	E13-0250-05	PHONE JACK		
E2		*	E13-0486-05	PHONE JACK		
E3		*	E13-0826-05	PHONE JACK		
F5			E20-0823-05	LNCK TERMINAL BOARD(BP)		
F6			E11-0162-05	PHONE JACK (3P)		
E7			E03-0093-05	AC OUTLET	KPUJUEM	
25	1B		J13-0054-05	FUSE CLIP		
L1 ,2			L39-0085-05	PHASE-COMPENSATION CNIL		
CP1 ,2			R90-0187-05	MULTI-COMP 0.22X2 K 5W		
R11 ,12			RD14GB2E101J	FL-PROOF RD 100 J 1/4W		J
R31			RD14GB2E221J	FL-PROOF RD 220 J 1/4W		S
R31 ,34			RD14GB2E221J	FL-PROOF RD 220 J 1/4W		J
R32			RD14AB2E221J	FL-PROOF RD 220 J 1/4W		J
R33			RD14GB2E221J	FL-PROOF RD 220 J 1/4W		J
R34			RD14AB2E221J	FL-PROOF RD 220 J 1/4W		J
R43 ,44			RS14DB3D561J	FL-PROOF RS 560 J 2W		J
R43 ,44			RS14KB3D561J	FL-PROOF RS 560 J 2W		S
R49 -52			RD14AB2E220J	FL-PROOF RD 22 J 1/4W		J
R49 -52			RD14GB2E220J	FL-PROOF RD 22 J 1/4W		S
R53 -56			RD14AB2E331J	FL-PROOF RD 330 J 1/4W		J
R53 -56			RD14GB2E331J	FL-PROOF RD 330 J 1/4W		S
R57 -60			RD14AB2E2R2J	FL-PROOF RD 2.2 J 1/4W		J
R57 -60			RD14GB2E2R2J	FL-PROOF RD 2.2 J 1/4W		S
R61			RS14DB3D100J	FL-PROOF RS 10 J 2W		J
R61 ,62			RS14KB3D100J	FL-PROOF RS 10 J 2W		S

E: Scandinavia & Europe K: USA P: Canada
 U: PX(Far East, Hawaii) T: England M: Other Areas
 UE: AAFES(Europe) X: Australia

J: Japan made

S: Singapore made

⚠ indicates safety critical components.

PARTS LIST

× New Parts

Parts without Parts No. are not supplied.

Les articles non mentionnés dans le Parts No. ne sont pas fournis.

Teile ohne Parts No. werden nicht geliefert.

Ref. No. 参照番号	Address 位置	New Parts 新	Parts No. 部品番号	Description 部品名 / 規格	Desti- nation 仕 向	Re- marks 備考
R62			RS14KB3D100J	FL-PR00F RS 10 J 2W		J
R71 ,72			RD14AB2E100J	FL-PR00F RD 10 J 1/4W		J
R71 ,72			RD14GB2E100J	FL-PR00F RD 10 J 1/4W		S
R120			RD14AB2E121J	FL-PR00F RD 120 J 1/4W		J
R120			RD14GB2E121J	FL-PR00F RD 120 J 1/4W		S
R121,122			RD14AB2E100J	FL-PR00F RD 10 J 1/4W		J
R121,122			RD14GB2E100J	FL-PR00F RD 10 J 1/4W		S
R131			RS14DB3A101J	FL-PR00F RS 100 J 1W		J
R131			RS14KB3A101J	FL-PR00F RS 100 J 1W		S
R132			RS14DB3A181J	FL-PR00F RS 180 J 1W		J
R132			RS14KB3A181J	FL-PR00F RS 180 J 1W		S
R133,134			RD14AB2E472J	FL-PR00F RD 4.7K J 1/4W		J
R133,134			RD14GB2E472J	FL-PR00F RD 4.7K J 1/4W		S
R143			RS14DB3D222J	FL-PR00F RS 2.2K J 2W	XE	
R143			RS14KB3D272J	FL-PR00F RS 2.7K J 2W	UJEM	
R143,144			RS14KB3D332J	FL-PR00F RS 3.3K J 2W	KP	
R144			RS14DB3D272J	FL-PR00F RS 2.7K J 2W	XE	
VR1 ,2			R12-10B3-05	TRIMMING POT. (1K)		
K1			S51-2078-05	MAGNETIC RELAY		
S1			S31-2136-05	SLIDE SWITCH (40→80)	UJEMX	
S1			S31-2136-05	SLIDE SWITCH (40→80)	E	
S2			S31-2131-05	SLIDE SWITCH (POWER TYPE)	UJEM	
S3			S42-2153-05	MULTIPLE PUSH SWITCH (SPEAKERS)		
△ S4			S40-1073-05	PUSH SWITCH (POWER)		
D1 -8			HSS104	DIODE		
D29 -32			1SS133	DIODE		
D33 -36			1SS133	DIODE		
D37 ,38			S5566B	DIODE		
			HZS13N(B2)	ZENER DIODE		
D37 ,38			RD13ES(B2)	ZENER DIODE		
D39 ,40			1SS133	DIODE		
D41			S5566B	DIODE		
D42 ,43			HZS20N(B)	ZENER DIODE		
D42 ,43			RD20ES(B)	ZENER DIODE		
D44			RBV-602LFA	DIODE		
D45			HZS10N(B)	ZENER DIODE		
D45			RD10ES(B)	ZENER DIODE		
D46			1SS133	DIODE		
IC1			LC7818	IC(ELECTRO CONTROL SWITCH (2H)		
IC2 ,3			UPC4570C-A	IC(OP AMP X2)		
IC4			UPC1237HA	IC(POWER AMP)		
Q1 -4			2SC1845(F,E)	TRANSISTOR		
Q5 -8			2SA992(F,E)	TRANSISTOR		
Q9 -14			2SC2632(Q,R,S)	TRANSISTOR		
Q15 ,16			2SA1124(Q,R,S)	TRANSISTOR		
Q17 ,18			2SA1535(Q,R,S)	TRANSISTOR		
Q19 ,20			2SC3944(Q,R,S)	TRANSISTOR		
Q21 ,22			2SA733(A)(Q,P)	TRANSISTOR		
Q21 ,22			2SA933S(Q,R)	TRANSISTOR		
Q23 -26			2SC2878(B)	TRANSISTOR		
Q27			2SA733(A)(Q,P)	TRANSISTOR		
Q27			2SA933S(Q,R)	TRANSISTOR		
Q28 ,29			2SC1740S(Q,R)	TRANSISTOR		
Q28 ,29			2SC945(A)(Q,P)	TRANSISTOR		

E: Scandinavia & Europe K: USA

P: Canada

J: Japan made

U: PX(Far East, Hawaii)

T: England

M: Other Areas

S: Singapore made

UJ: AAFES(Europe)

X: Australia

△ indicates safety critical components.

PARTS LIST

× New Parts

Parts without Parts No. are not supplied.

Les articles non mentionnés dans le Parts No. ne sont pas fournis.

Teile ohne Parts No. werden nicht geliefert.

Ref. No. 参照番号	Address 位置	New Parts 新	Parts No. 部品番号	Description 部品名/規格	Desti- nation 仕向	Re- marks 備考
Q30 Q30 Q31 Q32 Q39			2SA733(A) (Q,P) 2SA933S (Q,R) 2SD882 2SA954 (L,K) DTA124EN	TRANSISTOR TRANSISTOR TRANSISTOR TRANSISTOR DIGITAL TRANSISTOR		
TONE UNIT (X11-263X-XX) Japan made:0-11 Singapore made:0-10						
D1 -19			B30-1223-05	LED(LN21CPH(V)-C)		
C1 ,2			CF92FV1H104J	MF 0.10UF J		
C3 ,4			CF92FV1H223J	MF 0.022UF J		
C5 ,6			CF92FV1H333J	MF 0.033UF J		
C7 -10			CE04KW1H010M	ELECTRN 1.0UF 50WV		J
C7 -10			CE04LW1H010M	ELECTRN 1.0UF 50WV		S
C11 ,12			CE04KW1C100M	ELECTRN 10UF 16WV		J
C11 ,12		*	CE04LW1C100M	ELECTRN 10UF 16WV		S
C13			CE04KW1C101M	ELECTRN 100UF 16WV		J
C13			CE04LW1C101M	ELECTRN 100UF 16WV		S
C14 ,15			CE04KW1C100M	ELECTRN 10UF 16WV		J
C14 ,15		*	CE04LW1C100M	ELECTRN 10UF 16WV		S
C21 ,22			CE04KW1H3R3M	ELECTRN 3.3UF 50WV		J
C21 ,22			CE04LW1H3R3M	ELECTRN 3.3UF 50WV		S
C23 ,24			CK45FB1H391K	CERAMIC 390PF K		
C25 ,26			CK45FB1H152K	CERAMIC 1500PF K		
C27 ,28			CE04KW1H3R3M	ELECTRN 3.3UF 50WV		J
C27 ,28			CE04LW1H3R3M	ELECTRN 3.3UF 50WV		S
C29 ,30			CE04KW1C100M	ELECTRN 10UF 16WV		J
C29 ,30		*	CE04LW1C100M	ELECTRN 10UF 16WV		S
C31 ,32			CE04KW1H010M	ELECTRN 1.0UF 50WV		J
C31 ,32			CE04LW1H010M	ELECTRN 1.0UF 50WV		S
C33 ,34			CE04KW1HR22M	ELECTRN 0.22UF 50WV		J
C33 ,34			CE04LW1HR22M	ELECTRN 0.22UF 50WV		S
C35 ,36			CE04KW1HR47M	ELECTRN 0.47UF 50WV		J
C35 ,36			CE04LW1HR47M	ELECTRN 0.47UF 50WV		S
C37 ,38			CE04KW1HOR1M	ELECTRN 0.1UF 50WV		J
C37 ,38			CE04LW1HOR1M	ELECTRN 0.1UF 50WV		S
C39 ,40			CE04KW1HR22M	ELECTRN 0.22UF 50WV		J
C39 ,40			CE04LW1HR22M	ELECTRN 0.22UF 50WV		S
C41 ,42			CF92FV1H333J	MF 0.033UF J		
C43 ,44			CF92FV1H823J	MF 0.082UF J		
C45 ,46			CF92FV1H123J	MF 0.012UF J		
C47 ,48			CF92FV1H333J	MF 0.033UF J		
C49 ,50			CF92FV1H512J	MF 5100PF J		
C51 ,52			CF92FV1H123J	MF 0.012UF J		
C53 ,54			CF92FV1H202J	MF 2000PF J		
C55 ,56			CF92FV1H472J	MF 4700PF J		
C57 ,58			CK45FB1H821K	CERAMIC 820PF K		
R41			RD14GB2E100J	FL-PROOF RD 10 J 1/4W		
VR1			RO6-5176-05	POTENTIOMETER		
VR2		*	RO1-5063-05	POTENTIOMETER		
S1 -5			S40-1064-05	PUSH SWITCH		
S6			S40-4074-05	PUSH SWITCH		
S7 ,8			S40-2351-05	PUSH SWITCH		
D20			HSS104	DIODE		
D20			1SS133	DIODE		

E: Scandinavia & Europe K: USA P: Canada

U: PX(Far East, Hawaii) T: England M: Other Areas

UE: AAFES(Europe) X: Australia

J: Japan made

S: Singapore made

 indicates safety critical components.

PARTS LIST

× New Parts

Parts without Parts No. are not supplied.

Les articles non mentionnés dans le Parts No. ne sont pas fournis.

Teile ohne Parts No. werden nicht geliefert.

Ref. No. 参照番号	Address 位置	New Parts 新	Parts No. 部品番号	Description 部品名 / 規格	Desti- nation 仕 向	Re- marks 備考
D21 ,22			HZS2.7N(B2)	ZENER DIODE		J
D21 ,22			RD2.7ES(B2)	ZENER DIODE		
D23 ,24			HSS104	DIODE		
D23 ,24			1SS133	DIODE		
IC1 ,2			M5229P	IC (7CH GRAPHIC EQUALIZER)		
IC3			NJM2058D	IC (NP AMP X4)		
IC3			UPC4574C	IC (NP AMP X4)		
Q1 ,2			2SA733(A) (D,P)	TRANSISTOR		
Q1 ,2			2SA933S(D,R)	TRANSISTOR		
Q3 ,4			2SC1740S(D,R)	TRANSISTOR		
Q3 ,4			2SC945(A) (D,P)	TRANSISTOR		

E: Scandinavia & Europe

K: USA

P: Canada

J: Japan made

U: PX(Far East, Hawaii)

T: England

M: Other Areas

S: Singapore made

UE: AAFES(Europe)

X: Australia

⚠ indicates safety critical components

KA-88

SPECIFICATIONS

Rated Power Output (Except for Europe and UK)

100 watts per channel minimum RMS, both channels driven, at 8 ohms from 20 Hz to 20,000 Hz with no more than 0.05% total harmonic distortion. (FTC)

Both channel driven at 1 kHz into

8 ohms 120 W + 120 W

Maximum continuous output power (for Europe and UK) (IEC) from 63 Hz to 12,500 Hz 0.7% T.H.D.

at 8 ohms 90 W + 90 W

(DIN) 1,000 Hz at 8 ohms 90 W + 90 W

Total Harmonic Distortion 0.004% at 1/2 rated power into 8 ohms at 1 kHz

Intermodulation Distortion 0.03% at rated power (60 Hz : 7 kHz = 4 : 1) into 8 ohms

Damping Factor 30 (50 Hz at 8 ohms)

Power Bandwidth 10 Hz to 100 kHz at 0.2% T.H.D. 8 ohms

Frequency Response 10 Hz to 70 kHz, +0 dB, -3 dB

Signal-to-Noise Ratio (IHF-A)

Phono 75 dB for 2.5 mV input

Tuner, Tape, CD/AUX 100 dB

Input Sensitivity/Impedance

Phono 2.5 mV/47 k ohms

Tuner, Tape play, CD/AUX 150 mV/33 k ohms

Phono Maximum Input Level 100 mV, T.H.D. 0.05% at 1 kHz

Output Level/Impedance

Tape REC (Pin) 150 mV/330 ohms

Phono Frequency Response RIAA standard curve ± 0.5 dB (20 Hz to 20,000 Hz)

Graphic Equalizer Control

(60 Hz, 150 Hz, 400 Hz, 1 kHz, 2.4 kHz, 6 kHz, 15 kHz) ± 10 dB

Loudness Control +8 dB at 100 Hz (at -30 dB VOLUME Level)

General

Power Consumption 4 A (U.S.A. & Canada models) 180 W (Europe & Australia models) 230 W (Other countries)

Dimensions W: 440 mm (17-5/16") H: 133 mm (5-1/4") D: 275 mm (10-13/16")

Weight (Net) 7.5 kg (16.5 lb)

Kenwood follows a policy of continuous advancements in development. For this reason specifications may be changed without notice.

Kenwood poursuit une politique de progrès constants en ce qui concerne le développement. Pour cette raison, les spécifications sont sujettes à modifications sans préavis.

Kenwood strebt ständige, Verbesserungen in der Entwicklung an. Daher bleiben Änderungen der technischen Daten jederzeit vorbehalten.

Note:

Component and circuitry are subject to modification to insure best operation under differing local conditions. This manual is based on, the U.S.A. (K) standard, and provides information on regional circuit modification through use of alternate schematic diagrams, and information on regional component variations through use of parts list.

KENWOOD CORPORATION

Shonogi Shibuya Building, 17-5, 2-chome Shibuya, Shibuya-ku, Tokyo 150, Japan

KENWOOD U.S.A. CORPORATION

2201 East Dominguez Street, Long Beach, CA 90810,
550 Clark Drive, Mount Olive, NJ 07828, U.S.A.

KENWOOD ELECTRONICS CANADA INC.

P.O. Box 1075 959 Gana Court, Mississauga, Ontario, Canada L4T 4C2

KENWOOD ELECTRONICS BENELUX N.V.

Mechelsesteenweg 418 B-1930 Zaventem, Belgium

KENWOOD ELECTRONICS DEUTSCHLAND GMBH

Rembrucker-Str. 15, 6056 Heusenstamm, West Germany

TRIO-KENWOOD FRANCE S.A.

Hi-Fi-VIDEO-CAR Hi-Fi
13, Boulevard Ney, 75018 Paris, France

TRIO-KENWOOD U.K. LTD.

17 Bristol Road, The Metropolitan Centre, Greenford, Middx. UG 8UP England

KENWOOD ELECTRONICS AUSTRALIA PTY. LTD.

4E Woodcock Place, Lane Cove, N.S.W. 2066, Australia

KENWOOD & LEE ELECTRONICS, LTD.

Wang Kee Building, 4th Floor, 34-37, Connaught Road, Central, Hong Kong