

STR-GX211

SERVICE MANUAL

AEP Model

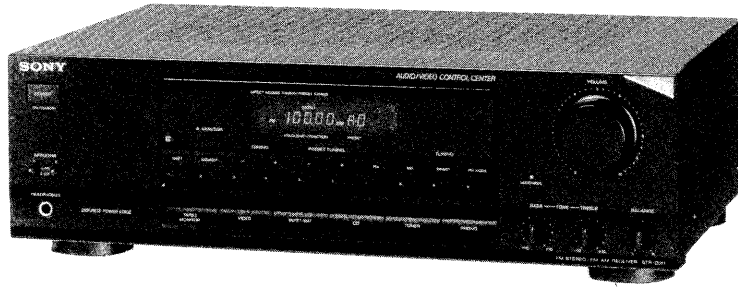

R-D-SEON

SPECIFICATIONS

Amplifier section

	Model for Scandinavian countries, Switzerland, Spain and Portugal	Model for other countries
DIN, 1 kHz	45 W + 45 W (8 ohms)	60 W + 60 W (4 ohms) 45 W + 45 W (8 ohms)
20 Hz - 20 kHz THD 0.3 %	40 W + 40 W (8 ohms)	50 W + 50 W (4 ohms) 40 W + 40 W (8 ohms)

Harmonic distortion

Less than 0.8% at rated output

Frequency response

PHONO: RIAA equalization curve ± 0.5 dB

CD
VIDEO
TAPE] 10 Hz - 50 kHz $\begin{matrix} +0 \\ -3 \end{matrix}$ dB

Inputs

	Sensitivity	Impedance	S/N (weighting network, input level)
PHONO	2.5 mV	50 kilohms	74 dB
CD, VIDEO TAPE 1, 2	200 mV	50 kilohms	95 dB

Outputs

REC OUT, VIDEO (AUDIO) OUT	Voltage 200 mV Impedance 10 kilohms
SPEAKER A, B	Accepts speakers of 8-16 ohms
HEADPHONES	Accepts low and high impedance headphones

Tone controls

BASS: ± 10 dB at 100 Hz

TREBLE: ± 10 dB at 10 kHz

Loudness

+6 dB (100 Hz)

— Continued on next page —

FM STEREO/FM-AM RECEIVER
SONY[®]

Tuner section

	FM tuner section	AM tuner section
Tuning range	87.5 – 108 MHz	531 – 1602 kHz
Antenna	75 ohms, unbalanced	External antenna terminal
Sensitivity at 50 dB quieting	18.3 dBf, 2.2 μ V (mono) 40 dBf, 24.5 μ V (stereo)	—
Usable sensitivity	11.2 dBf, 1 μ V (IHF)	Loop antenna: 300 μ V (at 999 kHz)
Signal-to-noise ratio	70 dB (mono) 66 dB (stereo)	54 dB (at 50 mV/m)
Harmonic distortion	0.3% (mono), 0.5% (stereo) at 1 kHz	0.5% (at 50 mV/m, 400 Hz)
Selectivity	60 dB at 400 kHz	30 dB at 10 kHz
Separation	45 dB at 1 kHz	—
Frequency response	30 Hz — 15 kHz ± 0.5 dB	—

General

System

Tuner section: PLL quartz-locked digital synthesizer system
 Preamplifier section: low-noise NF type equalizer amp
 Power amplifier section: pure complementary SEPP

Power requirements

220 – 230 V AC, 50/60 Hz

Power consumption

Model for Scandinavian countries, Switzerland, Spain and Portugal: 90 W
 Model for other countries: 130 W

Dimensions

Approx. 430 x 135 x 305 mm (w/h/d)
 (17 x 5 $\frac{3}{8}$ x 11 $\frac{7}{8}$ inches)
 including projecting parts and controls

Weight: Approx. 5.4 kg (11 lb 15 oz)

Accessories supplied

FM wire antenna (1)
 AM loop antenna (1)
 Sony batteries SUM-3(NS) (2)

Design and specifications are subject to change without notice.

Note

This appliance conforms with EEC Directive 87/308/EEC regarding interference suppression.

4-957-709-4 \square AE2 (AEP2) : Scandinavian countries, Switzerland, Spain and Portugal
 4-957-709-3 \square AE1 (AEP1) : Other European countries
 4-957-709-5 \square G : German

TABLE OF CONTENTS

Section	Title	Page
SECTION 1. GENERAL		
	Identifying the Parts and Controls	3
SECTION 2. DIAGRAMS		
2-1.	Circuit Boards Location	4
2-2.	Semiconductor Lead Layouts	4
2-3.	Block Diagram	5
2-4.	Printed Wiring Board — Main Section —	7
2-5.	Schematic Diagram — Main Section —	11
2-6.	Printed Wiring Board — Display Section —	16
2-7.	Schematic Diagram — Display Section —	18
2-8.	IC Block Diagrams	21
SECTION 3. EXPLODED VIEWS		
3-1.	Front Panel Section	22
3-2.	Chassis Section	23
SECTION 4. ELECTRICAL PARTS LIST		
		24

MODEL IDENTIFICATION

— BACK PANEL —

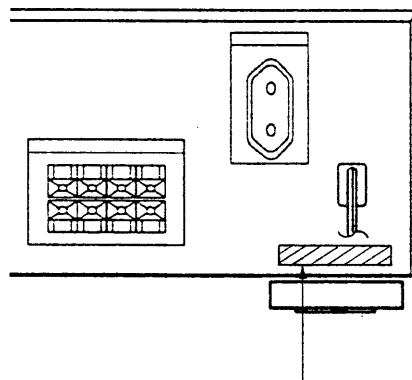

SAFETY-RELATED COMPONENT WARNING!!

COMPONENTS IDENTIFIED BY MARK \triangle OR DOTTED LINE WITH MARK \triangle ON THE SCHEMATIC DIAGRAMS AND IN THE PARTS LIST ARE CRITICAL TO SAFE OPERATION. REPLACE THESE COMPONENTS WITH SONY PARTS WHOSE PART NUMBERS APPEAR AS SHOWN IN THIS MANUAL OR IN SUPPLEMENTS PUBLISHED BY SONY.

SECTION 1 GENERAL

This section is extracted from
instruction manual.

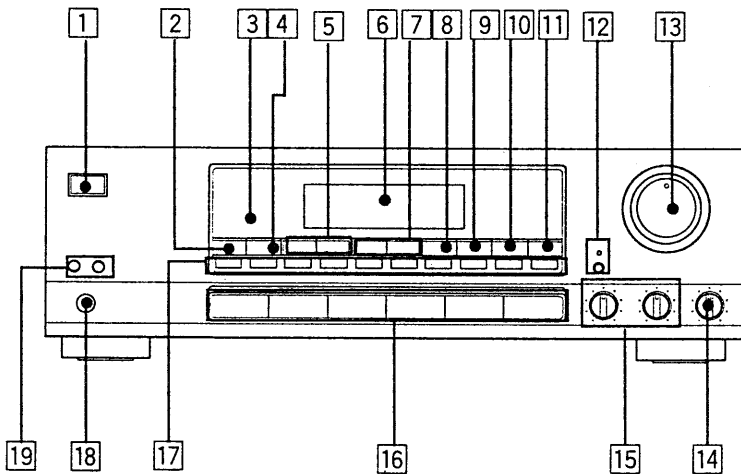

Identifying Parts and Controls

Front Panel

- 1 POWER switch
- 2 SHIFT button
- 3 MONITOR indicator
- 4 MEMORY button
- 5 TUNING +/- buttons
- 6 Display window
- 7 PRESET TUNING +/- buttons
- 8 FM button
- 9 AM button
- 10 TUNING DIRECT button
- 11 FM MODE button
- 12 LOUDNESS button and indicator
- 13 VOLUME control
- 14 BALANCE control
- 15 BASS/TREBLE controls
- 16 Function selectors

When the TAPE 2 MONITOR is pressed, the indicator of the last selected function also remains lit. But the TAPE 2 MONITOR button has priority and the taped or digital audio taped program can be heard.

- 17 Numeric buttons
- 18 HEADPHONES jack
- 19 SPEAKERS A/B buttons

SECTION 2 DIAGRAMS

2-1. CIRCUIT BOARDS LOCATION

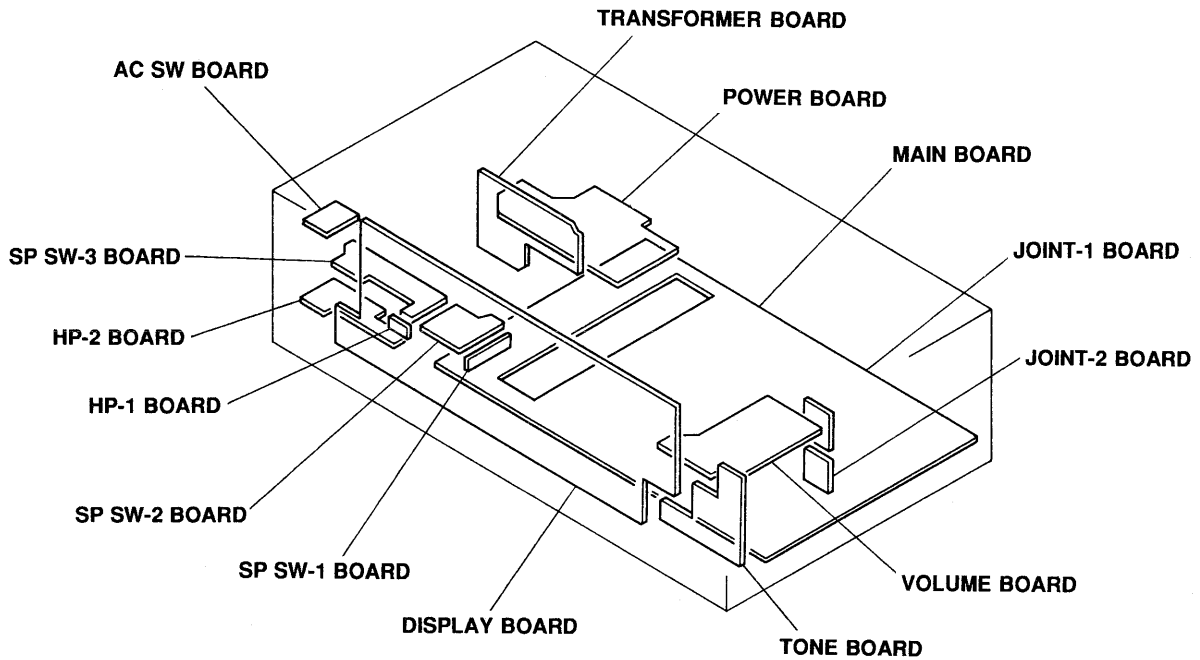

2-2. SEMICONDUCTOR LEAD LAYOUTS

LB1493
uPC4570HA-1

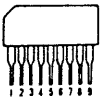

LC7822

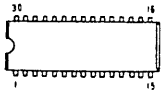

(Top view)

M5218AL

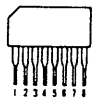

uPD75206GF-731-3BE

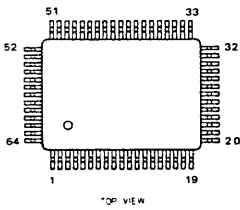

DTA124ES
DTC114TS
2SA1175-HFE
2SC2785-HFE
2SC3623A-LK

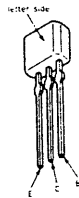

DTC124ES



2SA979-FG

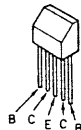

2SA988-PAFAEA

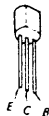

2SA1221-K
2SC2958



KSA708
2SD2012



2SB1587-OPY
2SD2438-OPY

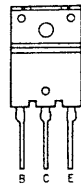

2SD809-K

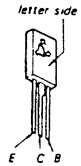

2SK246-GR3



HZS4ALL
UZ-12BSB
UZ-13BSB
UZL-24L
UZ-6.2BSC
1N4148M
1S1585

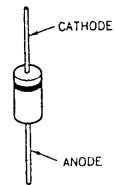

HZS6C3L
UZ-4.3BSB

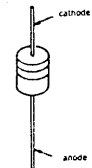

RBA-402

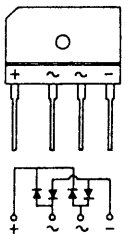

SEL3810A-CD

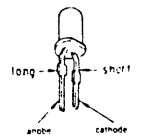

2-3. BLOCK DIAGRAM

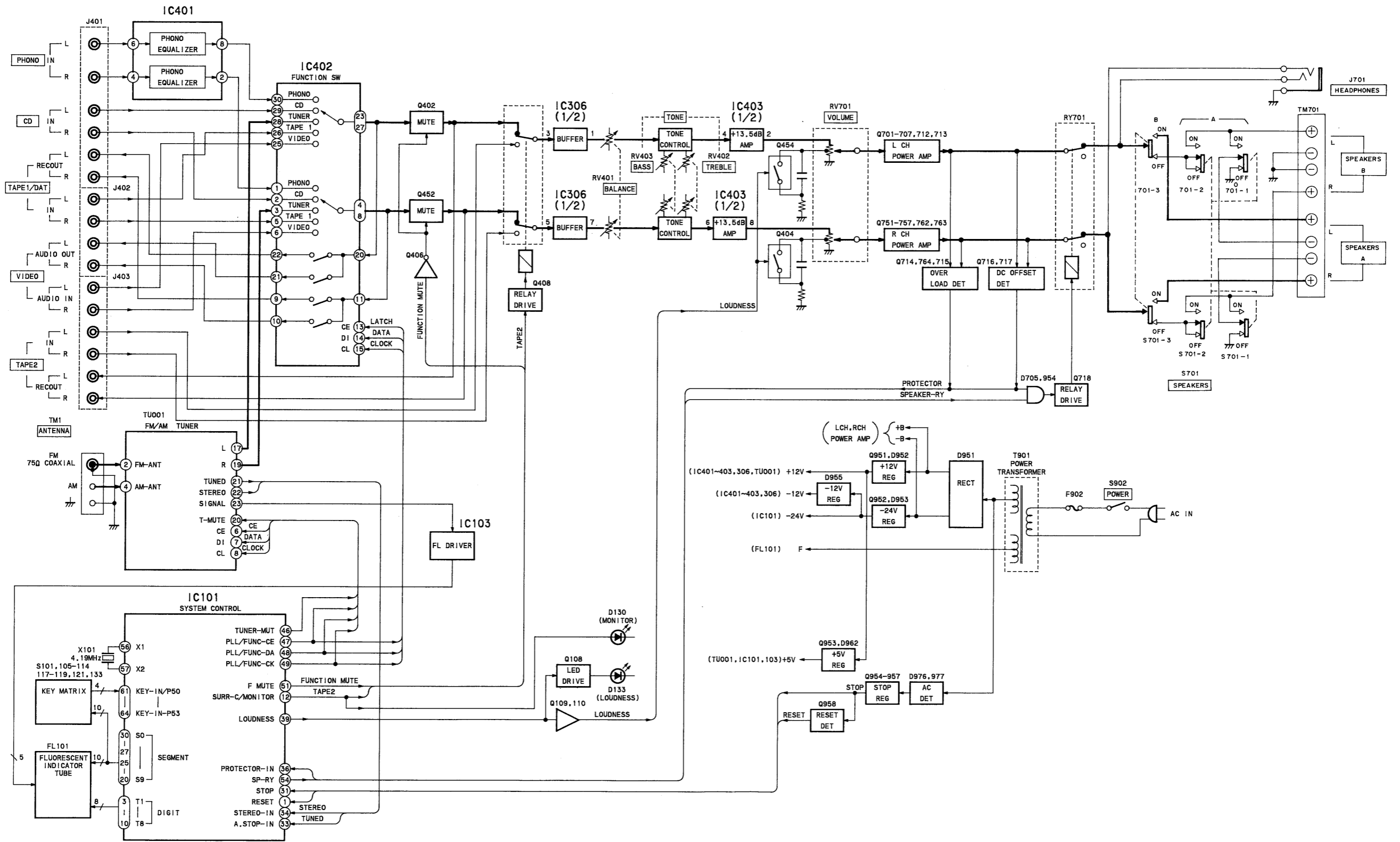

2-4. PRINTED WIRING BOARD — MAIN SECTION —
 • See page 4 for Circuit Boards Location and Semiconductor Lead Layouts.

• Semiconductor Location

Ref. No.	Location	Ref. No.	Location
D401	J-10	Q754	E-11
D403	C-14	Q755	D-12
D404	H-2	Q756	E-14
D701	F-11	Q757	D-12
D702	G-11	Q762	F-15
D703	H-13	Q763	D-15
D704	J-14	Q764	E-13
D705	G-12	Q951	H-8
D751	E-11	Q952	H-10
D752	E-11	Q953	I-12
D753	D-13	Q954	I-13
D951	E-13	Q955	I-12
D952	I-9	Q956	I-12
D953	G-10	Q957	H-12
D954	G-12	Q958	H-12
D955	G-10		
D956	H-11		
D962	I-13		
D963	J-13		
D964	I-13		
D965	H-12		
D976	F-12		
D977	F-12		
IC306	E-10		
IC401	C-9		
IC402	C-10		
IC403	G-3		
Q402	C-12		
Q404	G-2		
Q406	I-8		
Q408	C-14		
Q452	C-12		
Q454	G-4		
Q701	F-11		
Q702	F-11		
Q703	F-12		
Q704	F-11		
Q705	H-12		
Q706	G-14		
Q707	G-12		
Q712	H-15		
Q713	G-15		
Q714	H-13		
Q715	H-12		
Q716	G-11		
Q717	G-11		
Q718	H-11		
Q751	E-11		
Q752	C-12		
Q753	E-12		

Note:
 • — : parts extracted from the components side.
 • — : parts extracted from the conductor side.
 • : Pattern from the side which enable seen.

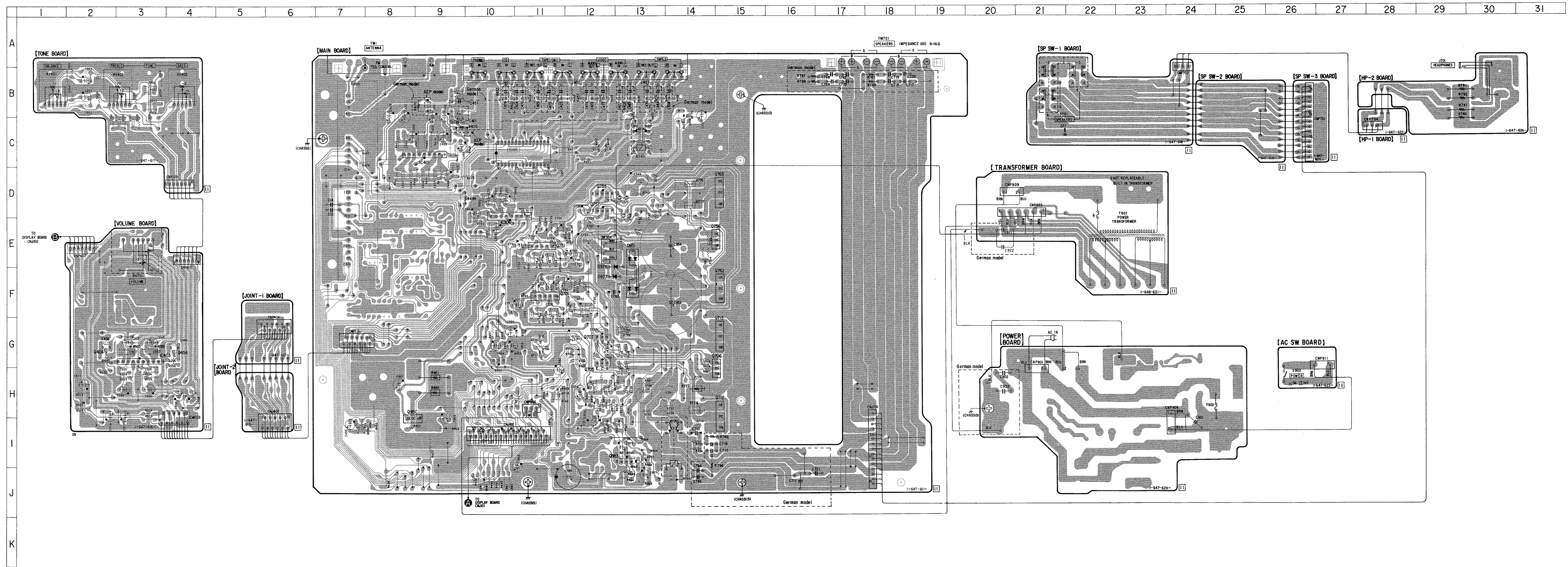

2-5. SCHEMATIC DIAGRAM — MAIN SECTION —
• See page 21 for IC Block Diagrams.

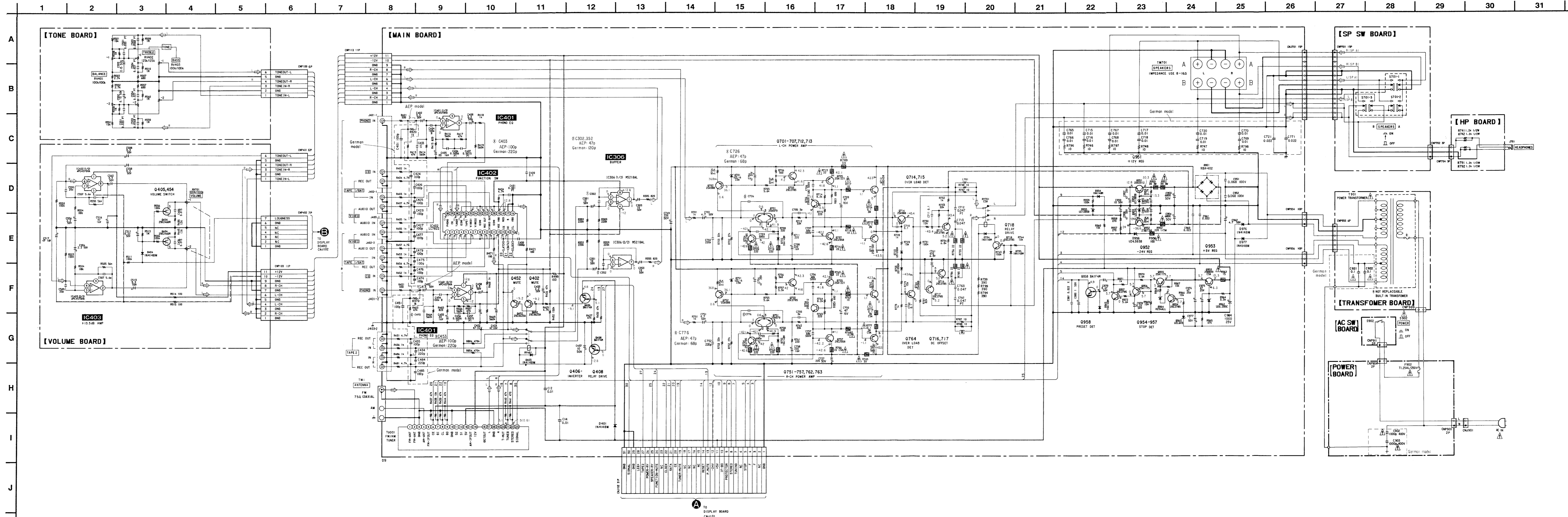

- Note:**
- All capacitors are in μF unless otherwise noted. pF : μF
 - 50WV or less are not indicated except for electrolytics and tantalums.
 - All resistors are in Ω and 1/4W or less unless otherwise specified.
 - % : indicates tolerance.
 - \square : nonflammable resistor.
 - \square : Panel designation.

Note: The components identified by mark Δ or dotted line with mark Δ are critical for safety. Replace only with part number specified.

- \oplus : B+ Line
- \ominus : B- Line
- Voltage and waveforms are dc with respect to ground under no-signal conditions.
- no mark : FM
- () : AM
- Voltages are taken with a VOM (Input impedance 10M Ω).
- Voltage variations may be noted due to normal production tolerances.
- Signal path. \Rightarrow : FM

2-6. PRINTED WIRING BOARD — DISPLAY SECTION —
• See page 4 for Circuit Boards Location and Semiconductor Lead Layouts.

• Semiconductor Location

Ref. No.	Location
D101	C-9
D102	C-9
D103	C-9
D104	C-9
D105	C-9
D106	C-9
D107	D-9
D108	D-9
D109	D-9
D111	D-7
D112	D-4
D113	D-4
D114	E-9
D116	F-6
D117	F-5
D130	D-10
D133	E-2
D135	E-2
IC101	D-6
IC103	D-8
Q108	E-2
Q109	F-2
Q110	F-3

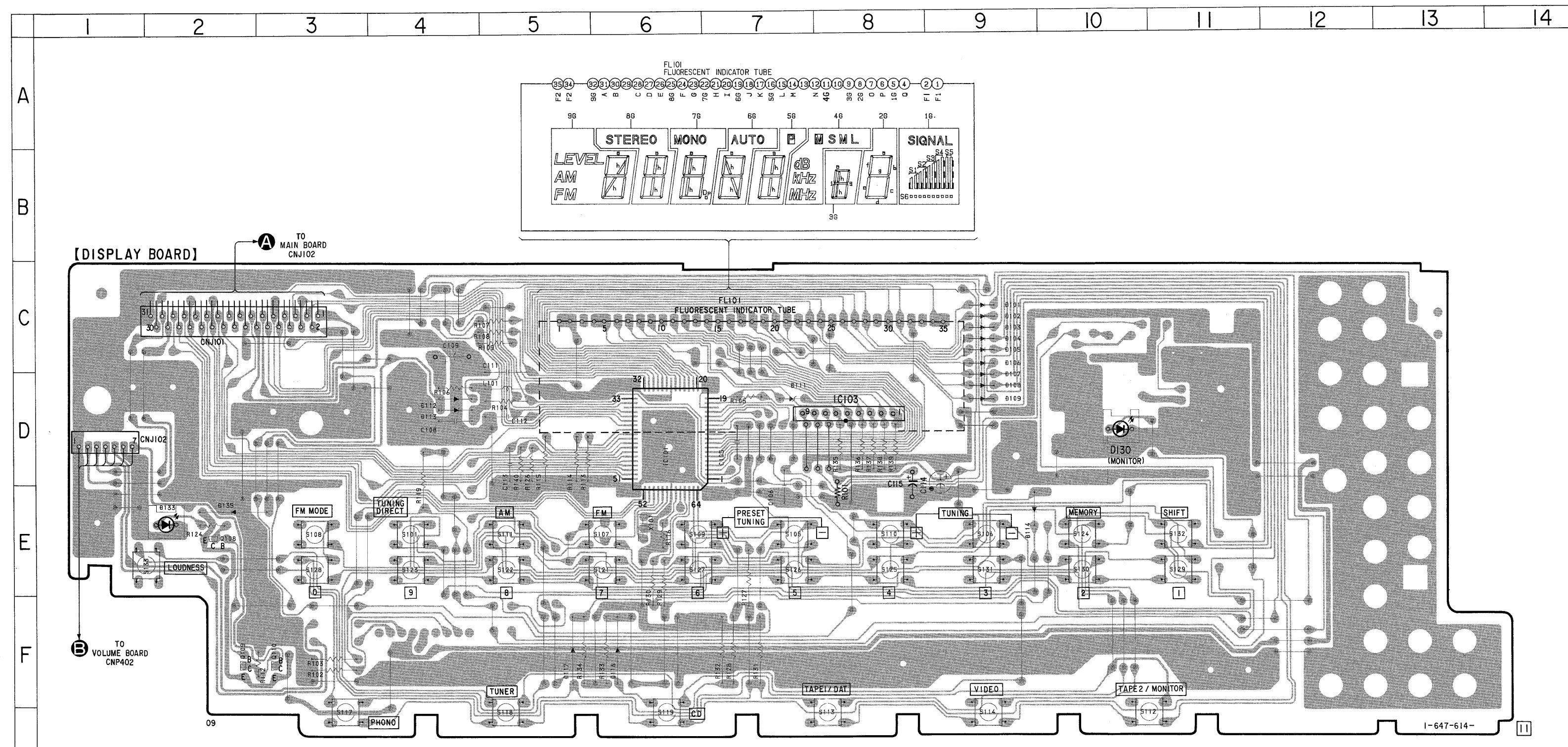

2-7. SCHEMATIC DIAGRAM — DISPLAY SECTION —
• See page 21 for IC Block Diagrams.

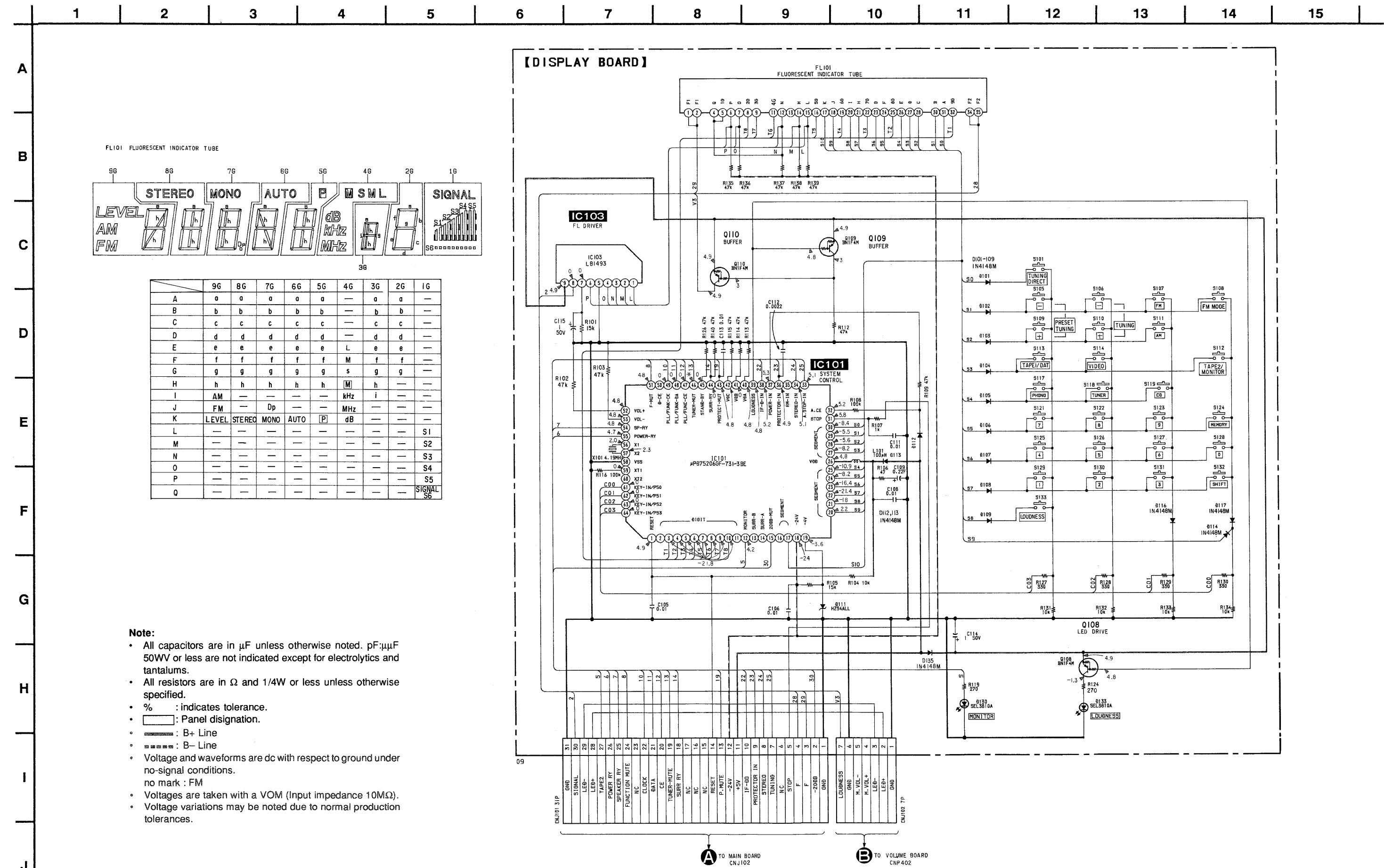

- Note:**
- All capacitors are in μF unless otherwise noted. pF ; μF 50WV or less are not indicated except for electrolytics and tantalums.
 - All resistors are in Ω and 1/4W or less unless otherwise specified.
 - % : Indicates tolerance.
 - □ : Panel designation.
 - — : B+ Line
 - - - - : B- Line
 - Voltage and waveforms are dc with respect to ground under no-signal conditions.
 - Voltages are taken with a VOM (Input impedance 10M Ω).
 - Voltage variations may be noted due to normal production tolerances.

Note:

- — : parts extracted from the components side.
- — : parts extracted from the conductor side.
- □ : Pattern from the side which enable seen.

2-8. IC BLOCK DIAGRAMS

IC103 LB1493

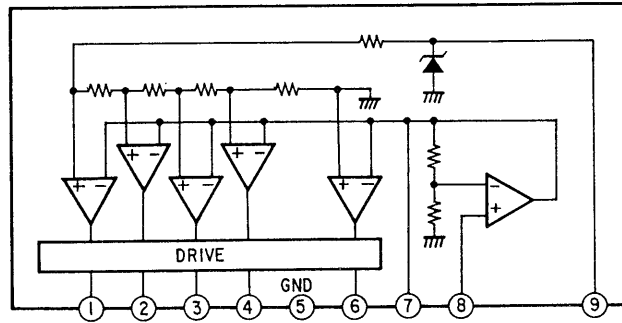

IC402 LC7822

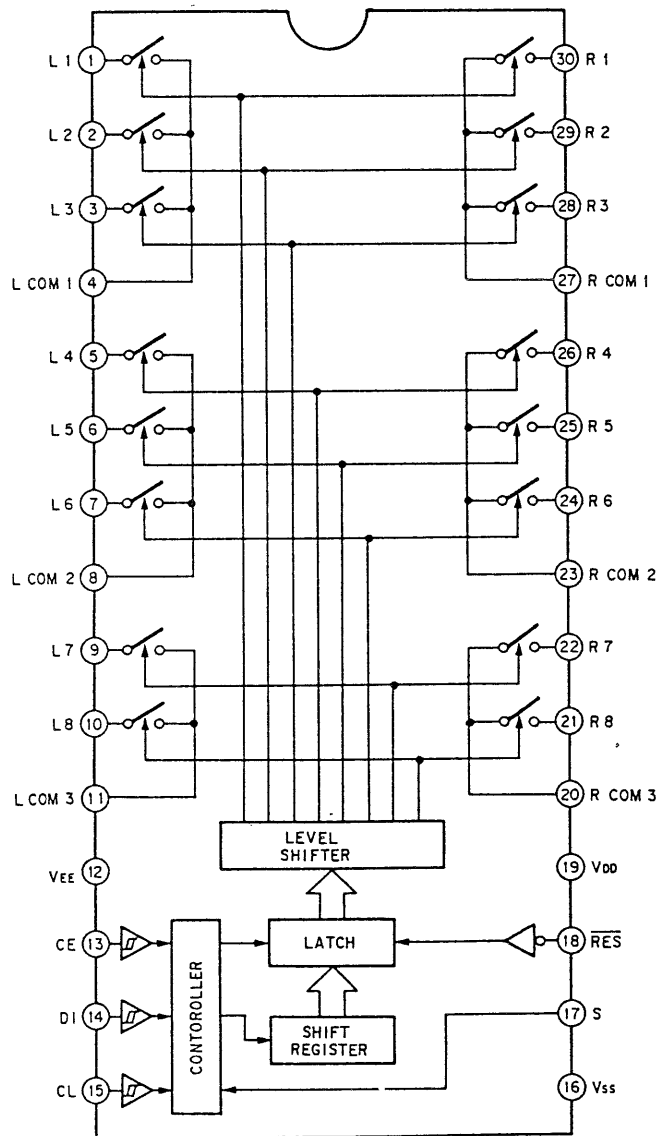

SECTION 3 EXPLODED VIEWS

NOTE:

- -XX, -X mean standardized parts, so they may have some difference from the original one.
- Items marked “ * ” are not stocked since they are seldom required for routine service. Some delay should be anticipated when ordering these items.

- The mechanical parts with no reference number in the exploded views are not supplied.
- Hardware (# mark) list is given in the last of this parts list.

The components identified by mark \triangle or dotted line with mark \triangle are critical for safety. Replace only with part number specified.

Note:

There are two type of AEP models which are depend on countries.
 AE2 (AEP2) model: Model for Scandinavian countries.
 Switzerland, Spain and Portugal
 AE1 (AEP1) model: Model for other European countries

3-1. FRONT PANEL SECTION

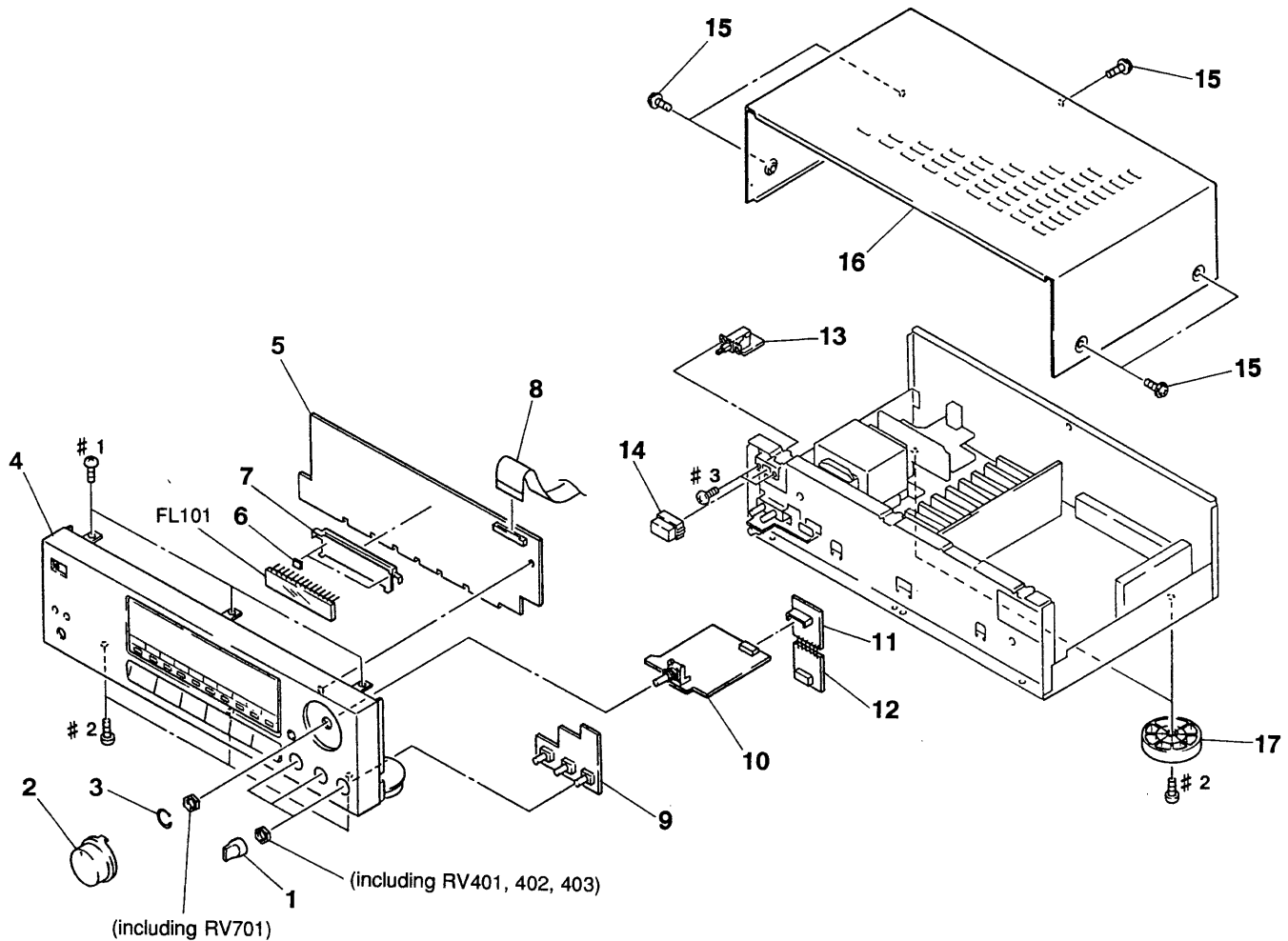

Ref. No.	Part No.	Description	Remark	Ref. No.	Part No.	Description	Remark
1	4-957-383-01	KNOB (F14)		* 11	1-647-612-11	JOINT-1 BOARD	
2	4-949-659-11	KNOB (VOL-NEW)		* 12	1-647-613-11	JOINT-2 BOARD	
3	3-350-426-01	SPRING, RING		* 13	1-647-623-11	AC SW BOARD	
4	X-4943-602-1	PANEL ASSY, FRONT		14	4-917-460-01	KNOB, POWER (POWER)	
* 5	A-4360-440-A	DISPLAY BOARD, COMPLETE		15	3-704-366-01	SCREW (CASE) (M3X8)	
* 6	4-921-941-01	CUSHION (FL)		* 16	4-951-795-01	CASE	
* 7	4-943-107-11	HOLDER (FL TUBE)		17	X-4941-292-1	FOOT ASSY (F58175S)	
8	1-696-456-11	WIRE (FLAT TYPE) (31 CORE)		FL101	1-519-731-11	INDICATOR TUBE, FLUORESCENT	
* 9	1-647-617-11	TONE BOARD					
* 10	A-4360-448-A	VOLUME BOARD, COMPLETE					

3-2. CHASSIS SECTION

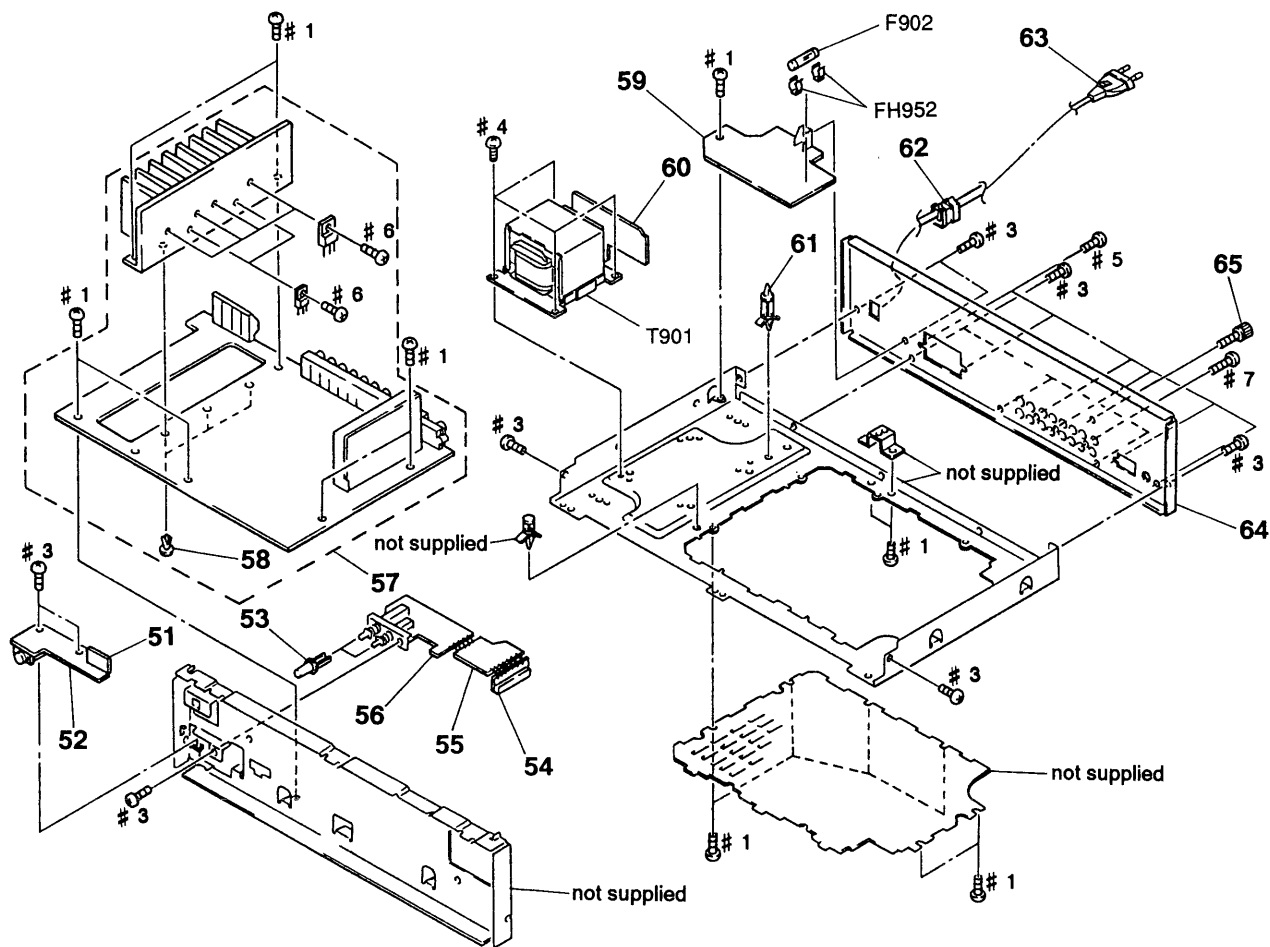

The components identified by mark ▲ or dotted line with mark △ are critical for safety. Replace only with part number specified.

Ref. No.	Part No.	Description	Remark	Ref. No.	Part No.	Description	Remark
* 51	1-647-622-11	HP-1 BOARD		* 61	4-924-098-31	HOLDER, PC BOARD	
* 52	1-647-626-11	HP-2 BOARD		* 62	3-703-244-00	BUSHING (2104), CORD	
53	4-951-801-02	BUTTON (S)		▲63	1-575-651-11	CORD, POWER	
* 54	1-647-618-11	SP SW-1 BOARD		* 64	4-957-709-31	PANEL, BACK (AEP1)	
* 55	1-647-619-11	SP SW-2 BOARD		* 64	4-957-709-41	PANEL, BACK (AEP2)	
* 56	1-647-620-11	SP SW-3 BOARD		* 64	4-957-709-51	PANEL, BACK (German)	
* 57	A-4360-439-A	MAIN BOARD, COMPLETE (AEP)		65	4-947-010-01	SCREW, FEEDER FIXED	
* 57	A-4360-443-A	MAIN BOARD, COMPLETE (German)		▲F902	1-532-285-00	FUSE (T1.25A 250V)	
58	4-812-134-00	RIVET NYLON, 3.5		▲T901	1-450-364-21	TRANSFORMER, POWER	
* 59	1-647-624-11	POWER BOARD		* FH952	1-533-293-11	HOLDER, FUSE	
* 60	1-648-627-11	TRANSFORMER BOARD					

SECTION 4

AC SW

DISPLAY

ELECTRICAL PARTS LIST

NOTE:

The components identified by mark Δ or dotted line with mark Δ are critical for safety.
 Replace only with part number specified.

When indicating parts by reference number, please include the board name.

- * Items marked "*" are not stocked since they are seldom required for routine service. Some delay should be anticipated when ordering these items.

- RESISTORS
 All resistors are in ohms
 METAL: Metal-film resistor
 METAL OXIDE: Metal Oxide-film resistor
 F : nonflammable
- SEMICONDUCTORS
 In each case, u: μ , for example:
 uA...: μ A..., uPA...: μ PA...,
 uPB...: μ PB..., uPC...: μ PC...,
 uPD...: μ PD...
- CAPACITORS
 uF : μ F
- COILS
 uH : μ H
- G: German model

- -XX, -X mean standardized parts, so they may have some difference from the original one.
- Due to standardization, replacements in the parts list may be different from the parts specified in the diagrams or the components used on the set.
- Hardware (# mark) list is given in the last of this parts list.

Note:

There are two type of AEP models which are depend on countries.
 AE2 (AEP2) model: Model for Scandinavian countries.
 Switzerland, Spain and Portugal
 AE1 (AEP1) model: Model for other European countries

Ref. No.	Part No.	Description	Remark	Ref. No.	Part No.	Description	Remark
*	1-647-623-11	AC SW BOARD *****		D112	8-719-987-63	DIODE IN4148M	
		< CONNECTOR >		D113	8-719-987-63	DIODE IN4148M	
* CNP901	1-580-230-11	PIN, CONNECTOR (PC BOARD) 3P < SWITCH >		D114	8-719-987-63	DIODE IN4148M	
Δ S902	1-572-267-21	SWITCH, PUSH (AC POWER) (1 KEY) (POWER)		D116	8-719-987-63	DIODE IN4148M	
*****				D117	8-719-987-63	DIODE IN4148M	
*	A-4360-440-A	DISPLAY BOARD, COMPLETE *****		D130	8-719-313-72	LED SEL3810A-CD	
		< CAPACITOR >		D133	8-719-313-72	LED SEL3810A-CD	
*	4-921-941-01	CUSHION (FL)		D135	8-719-987-63	DIODE IN4148M	
*	4-943-107-11	HOLDER (FL TUBE)				< FLUORESCENT INDICATOR >	
		< CAPACITOR >		FL101	1-519-731-11	INDICATOR TUBE, FLUORESCENT	
C105	1-161-379-00	CERAMIC 0.01uF 20% 25V				< IC >	
C106	1-161-379-00	CERAMIC 0.01uF 20% 25V		IC101	8-759-167-28	IC uPD75206GF-731-3BE	
C108	1-161-379-00	CERAMIC 0.01uF 20% 25V		IC103	8-759-800-95	IC LB1493	
C109	1-125-486-11	DOUBLE LAYERS 0.22F 5.5V				< COIL >	
C111	1-161-379-00	CERAMIC 0.01uF 20% 25V		L101	1-410-521-11	INDUCTOR 100uH	
C112	1-161-375-00	CERAMIC 0.0022uF 20% 50V				< TRANSISTOR >	
C113	1-161-379-00	CERAMIC 0.01uF 20% 25V		Q108	8-729-900-63	TRANSISTOR DTA124ES	
C114	1-126-301-11	ELECT 1uF 20% 50V		Q109	8-729-900-63	TRANSISTOR DTA124ES	
C115	1-126-301-11	ELECT 1uF 20% 50V		Q110	8-729-900-63	TRANSISTOR DTA124ES	
		< CONNECTOR >				< RESISTOR >	
* CNJ101	1-568-873-11	SOCKET, CONNECTOR 31P		R101	1-249-431-11	CARBON 15K 5% 1/4W	
* CNJ102	1-566-969-11	HOUSING, CONNECTOR(PC BOARD)7P		R102	1-249-437-11	CARBON 47K 5% 1/4W	
		< DIODE >		R103	1-249-437-11	CARBON 47K 5% 1/4W	
D101	8-719-987-63	DIODE IN4148M		R104	1-249-429-11	CARBON 10K 5% 1/4W	
D102	8-719-987-63	DIODE IN4148M		R105	1-249-431-11	CARBON 15K 5% 1/4W	
D103	8-719-987-63	DIODE IN4148M				< TRANSISTOR >	
D104	8-719-987-63	DIODE IN4148M		R106	1-249-401-11	CARBON 47 5% 1/4W	
D105	8-719-987-63	DIODE IN4148M		R107	1-249-417-11	CARBON 1K 5% 1/4W F	
D106	8-719-987-63	DIODE IN4148M		R108	1-249-441-11	CARBON 100K 5% 1/4W	
D107	8-719-987-63	DIODE IN4148M		R109	1-249-437-11	CARBON 47K 5% 1/4W	
D108	8-719-987-63	DIODE IN4148M		R112	1-249-437-11	CARBON 47K 5% 1/4W	
D109	8-719-987-63	DIODE IN4148M				< RESISTOR >	
D111	8-719-985-53	DIODE HZS4ALL		R113	1-249-437-11	CARBON 47K 5% 1/4W	
				R114	1-249-437-11	CARBON 47K 5% 1/4W	
				R115	1-249-437-11	CARBON 47K 5% 1/4W	
				R116	1-249-441-11	CARBON 100K 5% 1/4W	
				R119	1-249-410-11	CARBON 270 5% 1/4W F	
				R124	1-249-410-11	CARBON 270 5% 1/4W F	
				R126	1-249-437-11	CARBON 47K 5% 1/4W	

DISPLAY

HP-1

HP-2

JOINT-1

JOINT-2

MAIN

Ref. No.	Part No.	Description	Remark	Ref. No.	Part No.	Description	Remark
R127	1-249-411-11	CARBON 330 5% 1/4W		*	1-647-622-11	HP-1 BOARD *****	
R128	1-249-411-11	CARBON 330 5% 1/4W				< CONNECTOR >	
R129	1-249-411-11	CARBON 330 5% 1/4W				CNP704 1-691-160-11 PIN, CONNECTOR 3P	
R130	1-249-411-11	CARBON 330 5% 1/4W				*****	
R131	1-249-429-11	CARBON 10K 5% 1/4W		*	1-647-626-11	HP-2 BOARD *****	
R132	1-249-429-11	CARBON 10K 5% 1/4W				< JACK >	
R133	1-249-429-11	CARBON 10K 5% 1/4W		J701	1-568-151-11	JACK (LARGE TYPE) (HEADPHONES)	
R134	1-249-429-11	CARBON 10K 5% 1/4W				< RESISTOR >	
R135	1-249-437-11	CARBON 47K 5% 1/4W		R741	1-247-753-11	CARBON 1.2K 5% 1/2W	
R136	1-249-437-11	CARBON 47K 5% 1/4W		R742	1-247-753-11	CARBON 1.2K 5% 1/2W	
R137	1-249-437-11	CARBON 47K 5% 1/4W		R791	1-247-753-11	CARBON 1.2K 5% 1/2W	
R138	1-249-437-11	CARBON 47K 5% 1/4W		R792	1-247-753-11	CARBON 1.2K 5% 1/2W	
R139	1-249-437-11	CARBON 47K 5% 1/4W				*****	
R140	1-249-437-11	CARBON 47K 5% 1/4W		*	1-647-612-11	JOINT-1 BOARD *****	
		< SWITCH >				< CONNECTOR >	
S101	1-554-303-21	SWITCH, TACTILE (TUNING DIRECT)		* CNP404	1-750-384-11	CONNECTOR, BOARD TO BOARD 11P	
S105	1-554-303-21	SWITCH, TACTILE (PRESET TUNING -)				*****	
S106	1-554-303-21	SWITCH, TACTILE (TUNING -)		*	1-647-613-11	JOINT-2 BOARD *****	
S107	1-554-303-21	SWITCH, TACTILE (FM)				< JACK >	
S108	1-554-303-21	SWITCH, TACTILE (FM MODE)		* CNJ402	1-750-383-11	CONNECTOR, BOARD TO BOARD 11P	
S109	1-554-303-21	SWITCH, TACTILE (PRESET TUNING +)				*****	
S110	1-554-303-21	SWITCH, TACTILE (TUNING +)		*	A-4360-439-A	MAIN BOARD, COMPLETE (AEP) *****	
S111	1-554-303-21	SWITCH, TACTILE (AM)		*	A-4360-443-A	MAIN BOARD, COMPLETE (G) *****	
S112	1-554-303-21	SWITCH, TACTILE (TAPE2/MONITOR)				4-812-134-00 RIVET NYLON, 3.5	
S113	1-554-303-21	SWITCH, TACTILE (TAPE1/DAT)				4-942-204-01 PLATE, GROUND	
S114	1-554-303-21	SWITCH, TACTILE (VIDEO)				4-953-350-01 PLATE, GROUND	
S117	1-554-303-21	SWITCH, TACTILE (PHONO)				7-685-647-79 SCREW +BVTP 3X10 TYPE2 IT-3	
S118	1-554-303-21	SWITCH, TACTILE (TUNER)				7-682-548-04 SCREW +BVTT 3X8 (S)	
S119	1-554-303-21	SWITCH, TACTILE (CD)				< CAPACITOR >	
S121	1-554-303-21	SWITCH, TACTILE (7)		C12	1-161-379-00	CERAMIC 0.01uF 20% 25V	
S122	1-554-303-21	SWITCH, TACTILE (8)		C14	1-161-379-00	CERAMIC 0.01uF 20% 25V	
S123	1-554-303-21	SWITCH, TACTILE (9)				*****	
S124	1-554-303-21	SWITCH, TACTILE (MEMORY)					
S125	1-554-303-21	SWITCH, TACTILE (4)					
S126	1-554-303-21	SWITCH, TACTILE (5)					
S127	1-554-303-21	SWITCH, TACTILE (6)					
S128	1-554-303-21	SWITCH, TACTILE (0)					
S129	1-554-303-21	SWITCH, TACTILE (1)					
S130	1-554-303-21	SWITCH, TACTILE (2)					
S131	1-554-303-21	SWITCH, TACTILE (3)					
S132	1-554-303-21	SWITCH, TACTILE (SHIFT)					
S133	1-554-303-21	SWITCH, TACTILE (LOUDNESS)					
		< VIBRATOR >					
X101	1-577-101-11	VIBRATOR, CERAMIC (4.19MHz)					

MAIN

Ref. No.	Part No.	Description	Remark	Ref. No.	Part No.	Description	Remark
C301	1-124-907-11	ELECT	10uF 20% 50V	C704	1-124-477-11	ELECT	47MF 20% 16V
C302	1-162-215-31	CERAMIC	47PF 5% 50V (AEP)	C705	1-164-039-11	CERAMIC	3PF 0.25PF 50V
C302	1-162-283-31	CERAMIC	120PF 10% 50V (G)	C706	1-102-989-00	CERAMIC	68PF 5% 500V
C303	1-124-907-11	ELECT	10uF 20% 50V	C707	1-102-989-00	CERAMIC	68PF 5% 500V
C351	1-124-907-11	ELECT	10uF 20% 50V	C708	1-124-120-11	ELECT	220uF 20% 25V
C352	1-162-215-31	CERAMIC	47PF 5% 50V (AEP)	C709	1-124-477-11	ELECT	47MF 20% 16V
C352	1-162-283-31	CERAMIC	120PF 10% 50V (G)	C710	1-164-159-11	CERAMIC	0.1uF 50V
C353	1-124-907-11	ELECT	10uF 20% 50V	C711	1-164-159-11	CERAMIC	0.1uF 50V
C401	1-162-282-31	CERAMIC	100PF 10% 50V (G)	C712	1-136-161-00	FILM	0.047uF 5% 50V
C402	1-123-382-00	ELECT	3.3uF 20% 100V	C713	1-136-161-00	FILM	0.047uF 5% 50V
C403	1-162-282-31	CERAMIC	100PF 10% 50V (AEP)	C715	1-164-096-11	CERAMIC	0.01uF 50V (G)
C403	1-162-286-31	CERAMIC	220PF 10% 50V (G)	C716	1-164-096-11	CERAMIC	0.01uF 50V (G)
C404	1-162-282-31	CERAMIC	100PF 10% 50V	C717	1-164-096-11	CERAMIC	0.01uF 50V (G)
C405	1-124-034-51	ELECT	33uF 20% 16V	C718	1-164-096-11	CERAMIC	0.01uF 50V (G)
C406	1-137-437-11	FILM	0.0056uF 5% 50V	C719	1-164-096-11	CERAMIC	0.01uF 50V (G)
C407	1-137-365-11	FILM	0.0015uF 5% 50V	C720	1-164-096-11	CERAMIC	0.01uF 50V (G)
C408	1-123-382-00	ELECT	3.3uF 20% 100V	C721	1-161-494-00	CERAMIC	0.022uF 25V (G)
C420	1-164-159-11	CERAMIC	0.1uF 50V	C726	1-162-215-31	CERAMIC	47PF 5% 50V (AEP)
C422	1-124-477-11	ELECT	47MF 20% 16V	C726	1-162-219-31	CERAMIC	68PF 5% 50V (G)
C423	1-124-477-11	ELECT	47MF 20% 16V	C727	1-124-911-11	ELECT	220uF 20% 50V
C424	1-162-282-31	CERAMIC	100PF 10% 50V (G)	C749	1-124-911-11	ELECT	220uF 20% 50V
C425	1-162-282-31	CERAMIC	100PF 10% 50V (G)	C751	1-124-927-11	ELECT	4.7uF 20% 100V
C426	1-162-282-31	CERAMIC	100PF 10% 50V (G)	C752	1-162-286-31	CERAMIC	220PF 10% 50V
C427	1-162-282-31	CERAMIC	100PF 10% 50V (G)	C753	1-102-116-00	CERAMIC	680PF 10% 50V
C429	1-162-282-31	CERAMIC	100PF 10% 50V (G)	C754	1-124-477-11	ELECT	47MF 20% 16V
C430	1-162-294-31	CERAMIC	0.001uF 10% 50V	C755	1-164-039-11	CERAMIC	3PF 0.25PF 50V
C431	1-137-364-91	FILM	0.001uF 5% 50V	C756	1-102-989-00	CERAMIC	68PF 5% 500V
C433	1-124-925-11	ELECT	2.2uF 20% 100V	C757	1-102-989-00	CERAMIC	68PF 5% 500V
C434	1-162-286-31	CERAMIC	220PF 10% 50V (G)	C758	1-124-120-11	ELECT	220uF 20% 25V
C435	1-162-282-31	CERAMIC	100PF 10% 50V (G)	C759	1-124-477-11	ELECT	47MF 20% 16V
C437	1-124-907-11	ELECT	10uF 20% 50V	C760	1-164-159-11	CERAMIC	0.1uF 50V
C451	1-162-282-31	CERAMIC	100PF 10% 50V (G)	C761	1-124-472-11	ELECT	470uF 20% 10V
C452	1-123-382-00	ELECT	3.3uF 20% 100V	C762	1-136-161-00	FILM	0.047uF 5% 50V
C453	1-162-282-31	CERAMIC	100PF 10% 50V (AEP)	C763	1-136-161-00	FILM	0.047uF 5% 50V
C453	1-162-286-31	CERAMIC	220PF 10% 50V (G)	C765	1-164-096-11	CERAMIC	0.01uF 50V (G)
C454	1-162-282-31	CERAMIC	100PF 10% 50V	C766	1-164-096-11	CERAMIC	0.01uF 50V (G)
C455	1-124-034-51	ELECT	33uF 20% 16V	C767	1-164-096-11	CERAMIC	0.01uF 50V (G)
C456	1-137-437-11	FILM	0.0056uF 5% 50V	C768	1-164-096-11	CERAMIC	0.01uF 50V (G)
C457	1-137-365-11	FILM	0.0015uF 5% 50V	C769	1-164-096-11	CERAMIC	0.01uF 50V (G)
C458	1-123-382-00	ELECT	3.3uF 20% 100V	C770	1-164-096-11	CERAMIC	0.01uF 50V (G)
C474	1-162-282-31	CERAMIC	100PF 10% 50V (G)	C771	1-161-494-00	CERAMIC	0.022uF 25V (G)
C475	1-162-282-31	CERAMIC	100PF 10% 50V (G)	C776	1-162-215-31	CERAMIC	47PF 5% 50V (AEP)
C476	1-162-282-31	CERAMIC	100PF 10% 50V (G)	C776	1-162-219-31	CERAMIC	68PF 5% 50V (G)
C477	1-162-282-31	CERAMIC	100PF 10% 50V (G)	C951	1-108-702-11	MYLAR	0.068uF 10% 100V
C479	1-162-282-31	CERAMIC	100PF 10% 50V (G)	C952	1-108-702-11	MYLAR	0.068uF 10% 100V
C484	1-162-286-31	CERAMIC	220PF 10% 50V (G)	C953	1-125-614-11	ELECT	6800uF 20% 50V
C485	1-162-282-31	CERAMIC	100PF 10% 50V (G)	C953	1-128-506-11	ELECT	6800uF 20% 50V
C701	1-124-927-11	ELECT	4.7uF 20% 100V	C954	1-125-614-11	ELECT	6800uF 20% 50V
C702	1-162-286-31	CERAMIC	220PF 10% 50V	C954	1-128-506-11	ELECT	6800uF 20% 50V
C703	1-102-116-00	CERAMIC	680PF 10% 50V	C955	1-124-478-11	ELECT	100uF 20% 25V

Ref. No.	Part No.	Description	Remark
C956	1-124-910-11	ELECT 47uF 20% 50V	
C957	1-124-477-11	ELECT 47uF 20% 25V	
C958	1-124-910-11	ELECT 47uF 20% 50V	
C959	1-124-907-11	ELECT 10uF 20% 50V	
C960	1-161-494-00	CERAMIC 0.022uF 25V	
C961	1-161-494-00	CERAMIC 0.022uF 25V	
C962	1-124-927-11	ELECT 4.7uF 20% 100V	
C975	1-124-477-11	ELECT 47uF 20% 25V	
C976	1-124-477-11	ELECT 47uF 20% 25V	
C977	1-124-903-11	ELECT 1uF 20% 50V	
C978	1-124-464-11	ELECT 0.22uF 20% 50V	
C979	1-124-902-00	ELECT 0.47uF 20% 50V	
C980	1-124-903-11	ELECT 1uF 20% 50V	
C981	1-161-494-00	CERAMIC 0.022uF 25V	
C984	1-124-557-11	ELECT 1000uF 20% 25V	
< CONNECTOR >			
* CNJ102	1-568-845-11	SOCKET, CONNECTOR 31P	
CNJ701	1-573-095-11	SOCKET, CONNECTOR 15P	
* CNP113	1-750-384-11	CONNECTOR, BOARD TO BOARD 11P	
* CNP952	1-564-507-11	PLUG, CONNECTOR 4P	
* CNP954	1-564-104-00	PIN, CONNECTOR (B3P-VH) 3P	
* CNP956	1-564-506-11	PLUG, CONNECTOR 3P	
< DIODE >			
D401	8-719-987-63	DIODE 1N4148M	
D403	8-719-987-63	DIODE 1N4148M	
D701	8-719-933-41	DIODE HZS6C3L	
D702	8-719-987-63	DIODE 1N4148M	
D703	8-719-815-85	DIODE 1S1585	
D704	8-719-987-63	DIODE 1N4148M	
D705	8-719-987-63	DIODE 1N4148M	
D751	8-719-933-41	DIODE HZS6C3L	
D752	8-719-987-63	DIODE 1N4148M	
D753	8-719-815-85	DIODE 1S1585	
D951	8-719-312-09	DIODE RBA-402	
D952	8-719-010-78	DIODE UZ-13BSB	
D953	8-719-002-33	DIODE UZL-24L	
D954	8-719-987-63	DIODE 1N4148M	
D955	8-719-010-74	DIODE UZ-12BSB	
D956	8-719-010-29	DIODE UZ-4.3BSB	
D962	8-719-010-47	DIODE UZ-6.2BSC	
D963	8-719-933-41	DIODE HZS6C3L	
D964	8-719-985-53	DIODE HZS4ALL	
D965	8-719-987-63	DIODE 1N4148M	
D976	8-719-987-63	DIODE 1N4148M	
D977	8-719-987-63	DIODE 1N4148M	

Ref. No.	Part No.	Description	Remark
< IC >			
IC306	8-759-634-50	IC M5218AL	
IC401	8-759-112-93	IC uPC4570HA-1	
IC402	8-759-805-14	IC LC7822	
< JACK >			
J401	1-580-825-11	JACK, PIN 6P (VIDEO/TAPE2)	
J402	1-573-028-21	JACK, PIN 4P (VIDEO/TAPE1/DAT)	
J403	1-691-887-11	JACK, PIN 6P (PHONO/CD/TAPE1/DAT)	
< COIL >			
L701	1-420-872-00	COIL, AIR CORE	
L751	1-420-872-00	COIL, AIR CORE	
< TRANSISTOR >			
Q402	8-729-141-30	TRANSISTOR 2SC3623A-LK	
Q406	8-729-900-63	TRANSISTOR DTA124ES	
Q408	8-729-900-36	TRANSISTOR DTC124ES	
Q452	8-729-141-30	TRANSISTOR 2SC3623A-LK	
Q701	8-729-620-18	TRANSISTOR 2SA979-FG	
Q702	8-729-140-82	TRANSISTOR 2SA988-PAFAEA	
Q703	8-729-119-78	TRANSISTOR 2SC2785-HFE	
Q704	8-729-119-78	TRANSISTOR 2SC2785-HFE	
Q705	8-729-122-13	TRANSISTOR 2SA1221-K	
Q706	8-729-209-15	TRANSISTOR 2SD2012	
Q707	8-729-195-82	TRANSISTOR 2SC2958	
Q712	8-729-020-72	TRANSISTOR 2SD2438-OPY	
Q713	8-729-020-41	TRANSISTOR 2SB1587-OPY	
Q714	8-729-140-82	TRANSISTOR 2SA988-PAFAEA	
Q715	8-729-119-78	TRANSISTOR 2SC2785-HFE	
Q716	8-729-119-78	TRANSISTOR 2SC2785-HFE	
Q717	8-729-119-78	TRANSISTOR 2SC2785-HFE	
Q718	8-729-119-78	TRANSISTOR 2SC2785-HFE	
Q751	8-729-620-18	TRANSISTOR 2SA979-FG	
Q752	8-729-140-82	TRANSISTOR 2SA988-PAFAEA	
Q753	8-729-119-78	TRANSISTOR 2SC2785-HFE	
Q754	8-729-119-78	TRANSISTOR 2SC2785-HFE	
Q755	8-729-122-13	TRANSISTOR 2SA1221-K	
Q756	8-729-209-15	TRANSISTOR 2SD2012	
Q757	8-729-195-82	TRANSISTOR 2SC2958	
Q762	8-729-020-72	TRANSISTOR 2SD2438-OPY	
Q763	8-729-020-41	TRANSISTOR 2SB1587-OPY	
Q764	8-729-140-82	TRANSISTOR 2SA988-PAFAEA	
Q951	8-729-209-15	TRANSISTOR 2SD2012	
Q952	8-729-140-97	TRANSISTOR KSA708	
Q953	8-729-180-92	TRANSISTOR 2SD809-K	
Q954	8-729-119-78	TRANSISTOR 2SC2785-HFE	
Q955	8-729-119-76	TRANSISTOR 2SA1175-HFE	
Q956	8-729-119-76	TRANSISTOR 2SA1175-HFE	
Q957	8-729-119-78	TRANSISTOR 2SC2785-HFE	

MAIN

Ref. No.	Part No.	Description	Remark	Ref. No.	Part No.	Description	Remark
Q958	8-729-900-36	TRANSISTOR DTC124ES		R469	1-247-897-11	CARBON	560K 5% 1/4W
	< RESISTOR >			R470	1-249-417-11	CARBON	1K 5% 1/4W F (G)
				R471	1-249-408-11	CARBON	180 5% 1/4W F
R302	1-247-887-00	CARBON	220K 5% 1/4W	R481	1-249-425-11	CARBON	4.7K 5% 1/4W F
R303	1-247-887-00	CARBON	220K 5% 1/4W	R486	1-249-417-11	CARBON	1K 5% 1/4W F
R305	1-249-416-11	CARBON	820 5% 1/4W F	R499	1-249-405-11	CARBON	100 5% 1/4W F
R352	1-247-887-00	CARBON	220K 5% 1/4W	R701	1-249-417-11	CARBON	1K 5% 1/4W F
R353	1-247-887-00	CARBON	220K 5% 1/4W	R702	1-249-434-11	CARBON	27K 5% 1/4W
R355	1-249-416-11	CARBON	820 5% 1/4W F	R703	1-249-435-11	CARBON	33K 5% 1/4W
R401	1-249-411-11	CARBON	330 5% 1/4W	R704	1-249-421-11	CARBON	2.2K 5% 1/4W F
R402	1-249-417-11	CARBON	1K 5% 1/4W F	R705	1-249-426-11	CARBON	5.6K 5% 1/4W
R403	1-249-417-11	CARBON	1K 5% 1/4W F	R706	1-249-414-11	CARBON	560 5% 1/4W F
R404	1-249-425-11	CARBON	4.7K 5% 1/4W F	R707	1-249-423-11	CARBON	3.3K 5% 1/4W F
R405	1-249-417-11	CARBON	1K 5% 1/4W F	R708	1-249-411-11	CARBON	330 5% 1/4W
R407	1-249-425-11	CARBON	4.7K 5% 1/4W F	△R709	1-249-409-11	CARBON	220 5% 1/4W F
R413	1-249-437-11	CARBON	47K 5% 1/4W	△R710	1-249-409-11	CARBON	220 5% 1/4W F
R414	1-247-897-11	CARBON	560K 5% 1/4W	R711	1-249-409-11	CARBON	220 5% 1/4W F
R415	1-249-416-11	CARBON	820 5% 1/4W F	R712	1-249-435-11	CARBON	33K 5% 1/4W
R416	1-247-897-11	CARBON	560K 5% 1/4W	△R713	1-249-397-11	CARBON	22 5% 1/4W F
R417	1-249-437-11	CARBON	47K 5% 1/4W	R714	1-249-428-11	CARBON	8.2K 5% 1/4W F
R418	1-249-417-11	CARBON	1K 5% 1/4W F	R715	1-249-409-11	CARBON	220 5% 1/4W F
R419	1-247-897-11	CARBON	560K 5% 1/4W	△R716	1-249-397-11	CARBON	22 5% 1/4W F
R420	1-249-417-11	CARBON	1K 5% 1/4W F (G)	△R717	1-249-393-11	CARBON	10 5% 1/4W F
R421	1-249-408-11	CARBON	180 5% 1/4W F	△R718	1-249-393-11	CARBON	10 5% 1/4W F
R425	1-249-425-11	CARBON	4.7K 5% 1/4W F	△R726	1-208-601-21	WIREWOUND	0.1 10% 2W F
R426	1-249-437-11	CARBON	47K 5% 1/4W	△R727	1-208-601-21	WIREWOUND	0.1 10% 2W F
R427	1-249-437-11	CARBON	47K 5% 1/4W	R728	1-249-417-11	CARBON	1K 5% 1/4W F
R430	1-249-437-11	CARBON	47K 5% 1/4W	R729	1-249-431-11	CARBON	15K 5% 1/4W
R431	1-249-425-11	CARBON	4.7K 5% 1/4W F	R730	1-249-429-11	CARBON	10K 5% 1/4W
R432	1-247-883-00	CARBON	150K 5% 1/4W	R731	1-249-441-11	CARBON	100K 5% 1/4W
R434	1-249-425-11	CARBON	4.7K 5% 1/4W F	R732	1-249-417-11	CARBON	1K 5% 1/4W F
R436	1-249-417-11	CARBON	1K 5% 1/4W F	R733	1-249-435-11	CARBON	33K 5% 1/4W
R437	1-249-437-11	CARBON	47K 5% 1/4W	R734	1-249-427-11	CARBON	6.8K 5% 1/4W F
R438	1-249-429-11	CARBON	10K 5% 1/4W	△R735	1-249-397-11	CARBON	22 5% 1/4W F
R439	1-249-437-11	CARBON	47K 5% 1/4W	△R736	1-249-397-11	CARBON	22 5% 1/4W F
R440	1-249-437-11	CARBON	47K 5% 1/4W	R737	1-249-393-11	CARBON	10 5% 1/4W F
R441	1-249-413-11	CARBON	470 5% 1/4W F	R738	1-249-393-11	CARBON	10 5% 1/4W F
R444	1-249-437-11	CARBON	47K 5% 1/4W	R739	1-249-412-11	CARBON	390 5% 1/4W F
R451	1-249-411-11	CARBON	330 5% 1/4W	R743	1-249-441-11	CARBON	100K 5% 1/4W
R452	1-249-417-11	CARBON	1K 5% 1/4W F	R744	1-249-429-11	CARBON	10K 5% 1/4W
R453	1-249-417-11	CARBON	1K 5% 1/4W F	△R745	1-249-399-11	CARBON	33 5% 1/4W F
R454	1-249-425-11	CARBON	4.7K 5% 1/4W F	R746	1-249-393-11	CARBON	10 5% 1/4W F (G)
R455	1-249-417-11	CARBON	1K 5% 1/4W F	R747	1-249-393-11	CARBON	10 5% 1/4W F (G)
R457	1-249-425-11	CARBON	4.7K 5% 1/4W F	R748	1-249-393-11	CARBON	10 5% 1/4W F (G)
R463	1-249-437-11	CARBON	47K 5% 1/4W	△R749	1-249-399-11	CARBON	33 5% 1/4W F
R464	1-247-897-11	CARBON	560K 5% 1/4W	R751	1-249-417-11	CARBON	1K 5% 1/4W F
R465	1-249-416-11	CARBON	820 5% 1/4W F	R752	1-249-434-11	CARBON	27K 5% 1/4W
R466	1-247-897-11	CARBON	560K 5% 1/4W	R753	1-249-435-11	CARBON	33K 5% 1/4W
R467	1-249-437-11	CARBON	47K 5% 1/4W	R754	1-249-421-11	CARBON	2.2K 5% 1/4W F
R468	1-249-417-11	CARBON	1K 5% 1/4W F	R755	1-249-426-11	CARBON	5.6K 5% 1/4W

The components identified by mark △ or dotted line with mark △ are critical for safety. Replace only with part number specified.

MAIN**POWER****SP SW-1****SP SW-2**

Ref. No.	Part No.	Description	Value	Power	Temp	Remark	Ref. No.	Part No.	Description	Value	Power	Temp	Remark
R756	1-249-414-11	CARBON	560	5%	1/4W	F	R972	1-249-426-11	CARBON	5.6K	5%	1/4W	
R757	1-249-423-11	CARBON	3.3K	5%	1/4W	F			< RELAY >				
R758	1-249-411-11	CARBON	330	5%	1/4W								
△R759	1-249-409-11	CARBON	220	5%	1/4W	F	RY401	1-515-614-11	RELAY				
△R760	1-249-409-11	CARBON	220	5%	1/4W	F	RY701	1-515-533-11	RELAY				
R761	1-249-409-11	CARBON	220	5%	1/4W	F			< TERMINAL >				
R762	1-249-435-11	CARBON	33K	5%	1/4W								
△R763	1-249-397-11	CARBON	22	5%	1/4W	F	TM1	1-537-488-11	TERMINAL BOARD (ANT) (ANTENNA)				
R764	1-249-428-11	CARBON	8.2K	5%	1/4W	F	TM701	1-537-376-11	TERMINAL BOARD (SP) (SPEAKERS)				
R765	1-249-409-11	CARBON	220	5%	1/4W	F			< TUNER >				
△R766	1-249-397-11	CARBON	22	5%	1/4W	F							
△R767	1-249-393-11	CARBON	10	5%	1/4W	F	TU1	1-239-562-11	ENCAPSULATED COMPONENT (G)				
△R768	1-249-393-11	CARBON	10	5%	1/4W	F	TU1	1-239-611-11	ENCAPSULATED COMPONENT (AEP)				
△R776	1-208-601-21	WIREWOUND	0.1	10%	2W	F	*****						
△R777	1-208-601-21	WIREWOUND	0.1	10%	2W	F	*	1-647-624-11	POWER BOARD				
R778	1-249-417-11	CARBON	1K	5%	1/4W	F			*****				
R779	1-249-431-11	CARBON	15K	5%	1/4W				< CAPACITOR >				
R781	1-249-440-11	CARBON	82K	5%	1/4W		△C902	1-161-741-00	CERAMIC	0.001uF	10%	400V (G)	
△R785	1-249-397-11	CARBON	22	5%	1/4W	F	△C903	1-161-741-00	CERAMIC	0.001uF	10%	400V (G)	
△R786	1-249-397-11	CARBON	22	5%	1/4W	F			< CONNECTOR >				
R787	1-249-393-11	CARBON	10	5%	1/4W	F	* CNP901	1-564-321-00	PIN, CONNECTOR 2P				
R788	1-249-393-11	CARBON	10	5%	1/4W	F	* CNP904	1-580-230-11	PIN, CONNECTOR (PC BOARD) 3P				
R794	1-249-412-11	CARBON	390	5%	1/4W	F			< FUSE >				
R796	1-249-393-11	CARBON	10	5%	1/4W	F (G)	△F902	1-532-285-00	FUSE (T1.25A 250V)				
R797	1-249-393-11	CARBON	10	5%	1/4W	F (G)			< FUSE HOLDER >				
R798	1-249-393-11	CARBON	10	5%	1/4W	F (G)	FH902	1-533-217-31	HOLDER, FUSE				
R799	1-249-412-11	CARBON	390	5%	1/4W	F	*****						
R801	1-249-415-11	CARBON	680	5%	1/4W	F	*	1-647-618-11	SP SW-1 BOARD				
R804	1-247-895-00	CARBON	470K	5%	1/4W				*****				
R851	1-249-415-11	CARBON	680	5%	1/4W	F			< CONNECTOR >				
R854	1-247-895-00	CARBON	470K	5%	1/4W		CNP702	1-691-173-11	CONNECTOR (BOARD TO BOARD) 3P				
△R951	1-215-908-00	METAL OXIDE	33	5%	3W	F			< SWITCH >				
△R952	1-247-743-11	CARBON	220	5%	1/2W	F	S701	1-571-485-11	SWITCH, PUSH (2 KEY) (SPEAKERS)				
R953	1-249-422-11	CARBON	2.7K	5%	1/4W	F	*****						
R954	1-249-423-11	CARBON	3.3K	5%	1/4W	F	*	1-647-619-11	SP SW-2 BOARD				
△R955	1-215-908-00	METAL OXIDE	33	5%	3W	F			*****				
△R956	1-249-405-11	CARBON	100	5%	1/4W	F			< CONNECTOR >				
R957	1-249-410-11	CARBON	270	5%	1/4W	F							
R958	1-249-410-11	CARBON	270	5%	1/4W	F							
R959	1-249-441-11	CARBON	100K	5%	1/4W								
R960	1-249-429-11	CARBON	10K	5%	1/4W				< SWITCH >				
△R963	1-249-395-11	CARBON	15	5%	1/4W	F							
R964	1-249-423-11	CARBON	3.3K	5%	1/4W	F	S701	1-571-485-11	SWITCH, PUSH (2 KEY) (SPEAKERS)				
R965	1-249-437-11	CARBON	47K	5%	1/4W		*****						
R966	1-249-429-11	CARBON	10K	5%	1/4W		*	1-647-619-11	SP SW-2 BOARD				
R967	1-249-429-11	CARBON	10K	5%	1/4W				*****				
R968	1-249-417-11	CARBON	1K	5%	1/4W	F			< CONNECTOR >				
R969	1-249-429-11	CARBON	10K	5%	1/4W								
R970	1-249-426-11	CARBON	5.6K	5%	1/4W		*****						
R971	1-249-417-11	CARBON	1K	5%	1/4W	F							

The components identified by mark △ or dotted line with mark △ are critical for safety. Replace only with .part .number specified.

SP SW-3 **TONE** **TRANSFORMER** **VOLUME**

Ref.No.	Part No.	Description	Remark
*	1-647-620-11	SP SW-3 BOARD ***** < CONNECTOR >	
	CNP701 1-573-109-11	PIN, CONNECTOR 15P	

*	1-647-617-11	TONE BOARD ***** < CAPACITOR >	
	C501 1-130-489-00	MYLAR 0.033uF 5% 50V	
	C502 1-124-250-00	ELECT 0.15uF 20% 50V	
	C503 1-130-481-00	MYLAR 0.0068uF 5% 50V	
	C504 1-137-441-91	FILM 0.027uF 5% 50V	
	C551 1-130-489-00	MYLAR 0.033uF 5% 50V	
	C552 1-124-250-00	ELECT 0.15uF 20% 50V	
	C553 1-130-481-00	MYLAR 0.0068uF 5% 50V	
	C554 1-137-441-91	FILM 0.027uF 5% 50V	
		< CONNECTOR >	
*	CNP109 1-566-968-11	HOUSING, CONNECTOR(PC BOARD)6P < RESISTOR >	
	R501 1-249-429-11	CARBON 10K 5% 1/4W	
	R502 1-249-422-11	CARBON 2.7K 5% 1/4W F	
	R507 1-249-415-11	CARBON 680 5% 1/4W F	
	R508 1-247-903-00	CARBON 1M 5% 1/4W	
	R509 1-247-903-00	CARBON 1M 5% 1/4W	
	R510 1-247-903-00	CARBON 1M 5% 1/4W	
	R551 1-249-429-11	CARBON 10K 5% 1/4W	
	R552 1-249-422-11	CARBON 2.7K 5% 1/4W F	
	R557 1-249-415-11	CARBON 680 5% 1/4W F	
	R558 1-247-903-00	CARBON 1M 5% 1/4W	
	R559 1-247-903-00	CARBON 1M 5% 1/4W	
	R560 1-247-903-00	CARBON 1M 5% 1/4W	
		< VARIABLE RESISTOR >	
	RV401 1-223-362-11	RES, VAR, CARBON 100K/100K (BALANCE)	
	RV402 1-223-363-11	RES, VAR, CARBON 125K/125K (TREBLE)	
	RV403 1-238-965-21	RES, VAR, CARBON 100K/100K (BASS)	

*	1-648-631-11	TRANSFORMER BOARD ***** < CAPACITOR >	
	△C921 1-164-159-11	CERAMIC 0.1uF 50V (G)	
	△C922 1-164-159-11	CERAMIC 0.1uF 50V (G)	

Ref.No.	Part No.	Description	Remark
		< CONNECTOR >	
*	CNP909 1-568-226-11	PIN, CONNECTOR 2P	
*	CNP955 1-564-243-00	PIN, CONNECTOR 6P	
		< TRANSFORMER >	
	△T901 1-450-364-21	TRANSFORMER POWER	

*	A-4360-448-A	VOLUME BOARD, COMPLETE ***** < CAPACITOR >	
	C436 1-137-371-11	FILM 0.015uF 5% 50V	
	C486 1-137-371-11	FILM 0.015uF 5% 50V	
	C505 1-162-206-31	CERAMIC 20PF 5% 50V	
	C506 1-124-925-11	ELECT 2.2uF 20% 100V	
	C507 1-162-196-31	CERAMIC 5.6PF 10% 50V	
	C508 1-123-382-00	ELECT 3.3uF 20% 100V	
	C511 1-124-464-11	ELECT 0.22uF 20% 50V	
	C513 1-123-382-00	ELECT 3.3uF 20% 100V	
	C516 1-124-477-11	ELECT 47uF 20% 25V	
	C517 1-124-477-11	ELECT 47uF 20% 25V	
	C555 1-162-206-31	CERAMIC 20PF 5% 50V	
	C556 1-124-925-11	ELECT 2.2uF 20% 100V	
	C557 1-162-196-31	CERAMIC 5.6PF 10% 50V	
	C558 1-123-382-00	ELECT 3.3uF 20% 100V	
	C563 1-123-382-00	ELECT 3.3uF 20% 100V	
		< CONNECTOR >	
*	CNP103 1-750-383-11	CONNECTOR, BOARD TO BOARD 11P	
*	CNP401 1-566-971-11	PIN, CONNECTOR (PC BOARD) 6P	
*	CNP402 1-566-972-11	PIN, CONNECTOR (PC BOARD) 7P	
		< DIODE >	
	D404 8-719-987-63	DIODE 1N4148M	
		< IC >	
	IC403 8-759-112-93	IC uPC4570HA-1	
		< TRANSISTOR >	
	Q404 8-729-202-67	TRANSISTOR 2SK246-GR3	
	Q454 8-729-202-67	TRANSISTOR 2SK246-GR3	
		< RESISTOR >	
	R445 1-247-858-11	CARBON 13K 5% 1/4W	
	R495 1-247-858-11	CARBON 13K 5% 1/4W	
	R503 1-249-441-11	CARBON 100K 5% 1/4W	
	R504 1-249-432-11	CARBON 18K 5% 1/4W	
	R505 1-249-438-11	CARBON 56K 5% 1/4W	

The components identified by mark △ or dotted line with mark △ are critical for safety. Replace only with part number specified.

Ref. No.	Part No.	Description				Remark
R506	1-249-441-11	CARBON	100K	5%	1/4W	
R511	1-249-441-11	CARBON	100K	5%	1/4W	
R513	1-247-903-00	CARBON	1M	5%	1/4W	
R514	1-249-405-11	CARBON	100	5%	1/4W	F
R515	1-249-405-11	CARBON	100	5%	1/4W	F
R553	1-249-441-11	CARBON	100K	5%	1/4W	
R554	1-249-432-11	CARBON	18K	5%	1/4W	
R555	1-249-438-11	CARBON	56K	5%	1/4W	
R556	1-249-441-11	CARBON	100K	5%	1/4W	

< VARIABLE RESISTOR >

RV701 1-241-852-11 RES, VAR, CARBON 100K/100K (VOLUME)

MISCELLANEOUS

- 8 1-696-456-11 WIRE (FLAT TYPE) (31 CORE)
- △63 1-575-651-11 CORD, POWER
- △F902 1-532-285-00 FUSE (T1. 25A 250V)
- △T901 1-450-364-21 TRANSFORMER, POWER
- FL101 1-519-731-11 INDICATOR TUBE, FLUORESCENT

* FH952 1-533-293-11 HOLDER, FUSE

ACCESSORIES & PACKING MATERIALS

- 1-501-374-11 ANTENNA, LOOP
- 1-501-594-11 ANTENNA (FM)
- 3-756-537-11 MANUAL, INSTRUCTION
(ENGLISH, FRENCH, GERMAN, DUTCH) (AEP)
- 3-756-537-41 MANUAL, INSTRUCTION (GERMAN) (G)
- 3-756-537-51 MANUAL, INSTRUCTION
(SPANISH, SWEDISH, DANISH, FINNISH) (AEP2)
- * 4-952-676-01 CUSHION
- * 4-957-831-01 INDIVIDUAL CARTON

HARDWARE LIST

- #1 7-682-548-04 SCREW +BVTT 3X8 (S)
- #2 7-682-548-09 SCREW +BVTT 3X8 (S)
- #3 7-682-547-09 SCREW +BVTT 3X6 (S)
- #4 7-682-560-04 SCREW +BVTT 4X6 (S)
- #5 7-685-646-79 SCREW +BVTP 3X8 TYPE2 N-S
- #6 7-685-647-79 SCREW +BVTP 3X10 TYPE2 IT-3
- #7 7-621-849-00 SCREW, TAPPING

The components identified by mark △ or dotted line with mark △ are critical for safety. Replace only with part number specified.

